



BEACH COMMUNITY DEVELOPMENT DISTRICT

Advanced Meeting Package

Regular Meeting

*Monday
December 18, 2023
6:00 p.m.*

*Location:
12788 Meritage Blvd.,
Jacksonville, FL 32246*

*Note: The Advanced Meeting Package is a working document and thus all materials are considered **DRAFTS** prior to presentation and Board acceptance, approval, or adoption.*

Beach

Community Development District

250 International Parkway, Suite 208
Lake Mary, FL 32746
321-263-0132

Board of Supervisors
Beach Community Development District

Dear Board Members:

The Regular Meeting of the Board of Supervisors of the Beach Community Development District is scheduled for **Monday, December 18, 2023, at 6:00 p.m.** at the **12788 Meritage Blvd., Jacksonville, FL 32246**

An advanced copy of the agenda for the meeting is attached along with associated documentation for your review and consideration. Any additional support material will be distributed at the meeting.

Should you have any questions regarding the agenda, please contact me at (321) 263-0132 X-193 or dmcinnes@vestapropertyservices.com. We look forward to seeing you at the meeting.

Sincerely,

David McInnes

David McInnes
District Manager

Cc: Attorney
Engineer
District Records

Beach Community Development District

Meeting Date: Monday, December 18, 2023 Call-in Number: +1 (929) 205-6099
Time: 6:00 PM Meeting ID: 705 571 4830#
Location: 12788 Meritage Blvd., (Listen Only)
Jacksonville, FL 32246

Revised Agenda

- I. Roll Call**
- II. Pledge of Allegiance**
- III. Audience Comments** – (limited to 3 minutes per individual for agenda items)
- IV. Presentation of Proof of Publication(s)** [Exhibit 1](#)
- V. Discussion Topics**
 - A. Joseph Brown, Esquire – 30mins. Allotted
 - B. Trustee, Ed Edmiston, BNY Mellon – 20mins. Allotted
- VI. Vendor Reports**
 - A. Vesta Property Services
 - 1. Lifestyle Management Report – 10mins. Allotted [Exhibit 2](#)
 - 2. Field Management Report – 10mins. Allotted [Exhibit 3](#)
 - a. Consideration of Speed Bump Installation [Exhibit 4](#)
 - B. Advanced Security Specialist – 10mins. Allotted
 - C. Tree Amigos – 10mins. Allotted
- VII. Consent Agenda – 5mins. Allotted**
 - A. Consideration for Approval – The Minutes of the Board of Supervisors Workshop Held on October 25, 2023 [Exhibit 5](#)
 - B. Consideration for Approval – The Minutes of the Board of Supervisors Regular Meeting Held on November 20, 2023 [Exhibit 6](#)
 - C. Consideration for Acceptance – The Revised June 2023 Unaudited Financial Statements [Exhibit 7](#)
 - D. Consideration for Acceptance – The Revised July 2023 Unaudited Financial Statements [Exhibit 8](#)
 - E. Consideration for Acceptance – The Revised August 2023 Unaudited Financial Statements [Exhibit 9](#)
 - F. Consideration for Acceptance – The November 2023 Unaudited Financial Statements [Exhibit 10](#)

VII. Consent Agenda – continued

- G. Ratification of Integrated Access Solutions Emergency Repair Invoice [Exhibit 11](#)

VIII. Business Items

- A. Consideration of LLS Tax Solutions Arbitrage Engagement Letters for 11/03/24 & 11/03/25 – 5mins. Allotted [Exhibit 12](#)
- B. Acceptance of Parcels from Developer – 30mins. Allotted [Exhibit 13](#)
1. Transfer Parcel #1 [Exhibit 14](#)
 2. Transfer Parcel #2 [Exhibit 15](#)
 3. Transfer Parcel #3 [Exhibit 16](#)
 4. Transfer Parcel #4 [Exhibit 17](#)
 5. Transfer Parcel #5 [Exhibit 18](#)
 6. Transfer Parcel #6 [Exhibit 19](#)
 7. Transfer Parcel #7 [Exhibit 20](#)
- C. Consideration of Amenity Center Fountain Replacement Proposal – 15mins. Allotted – *previously presented*
1. Charles Aquatics [Exhibit 21](#)
 2. Lake Doctors [Exhibit 22](#)
- D. Consideration & Adoption of **Resolution 2024-04**, Appointing Assistant Treasurer – 5mins. Allotted [Exhibit 23](#)
- E. Consideration & Adoption of **Resolution 2024-05**, Designating Signatories – 5mins. Allotted [Exhibit 24](#)
- F. **Consideration of Bob’s Backflow Plumbing Services Repair Proposal – 5mins allotted** [Exhibit 25](#)

IX. Staff Reports

- A. District Counsel – 10mins. Allotted
- B. District Engineer
- C. District Manager – 25mins. Allotted
1. Resident(s) Subject Disciplinary Action
 2. Complaint & Incident Management Tracker
 3. **Action Item Report** [Exhibit 26](#)
 4. Meeting Matrix [Exhibit 27](#)
 5. Next Workshop Date, Time, & Topic(s)

X. Supervisors’ Requests – 20mins. Allotted

XI. Audience Comments (*limited to 3 minutes per individual for non-agenda items*)

XII. Action Items Summary – 5mins. Allotted

XIII. Meeting Matrix Summary – 5mins. Allotted

XIV. Next Meeting Quorum Check: January 15, 6:00 PM

Elena Korsakova	<input type="checkbox"/> IN PERSON	<input type="checkbox"/> REMOTE	<input type="checkbox"/> NO
Chance Wedderburn	<input type="checkbox"/> IN PERSON	<input type="checkbox"/> REMOTE	<input type="checkbox"/> NO
Sheila S. Papelbon	<input type="checkbox"/> IN PERSON	<input type="checkbox"/> REMOTE	<input type="checkbox"/> NO
Matt Calderaro	<input type="checkbox"/> IN PERSON	<input type="checkbox"/> REMOTE	<input type="checkbox"/> NO
Robert Renn	<input type="checkbox"/> IN PERSON	<input type="checkbox"/> REMOTE	<input type="checkbox"/> NO

XV. Adjournment

EXHIBIT 1

**BEACH COMMUNITY
DEVELOPMENT DISTRICT
NOTICE OF BOARD
OF SUPERVISORS
REGULAR MEETING**

Notice is hereby given that a regular meeting of the Board of Supervisors of the Beach Community Development District (the "**District**") will be held on Monday, December 18, 2023, at 6:00 p.m. at 12788 Meritage Blvd. Jacksonville, FL 32246. The purpose of the meeting is to discuss any topics presented to the board for consideration.

Copies of the agenda may be obtained from the District Manager, Vesta District Services, 250 International Parkway, Suite 208, Lake Mary, Florida 32746, Telephone (321) 263-0132, Ext. 193.

The meeting is open to the public and will be conducted in accordance with the provisions of Florida law for community development districts. The meeting may be continued in progress without additional notice to a date, time, and place to be specified on the record at the meeting. There may be occasions when Staff and/or Supervisors may participate by speaker telephone.

Pursuant to provisions of the Americans with Disabilities Act, any person requiring special accommodations to participate in the meeting is asked to advise the District Manager's office at least forty-eight (48) hours before the meeting by contacting the District Manager at (321) 263-0132, Ext. 193. If you are hearing or speech impaired, please contact the Florida Relay Service at 711, for assistance in contacting the District Manager's office.

A person who decides to appeal any decision made at the meeting, with respect to any matter considered at the meeting, is advised that a record of the proceedings is needed and that accordingly, the person may need to ensure that a verbatim record of the proceedings is made, including the testimony and evidence upon which the appeal is to be based.

Beach Community

Development District

David McInnes, District Manager

(321) 263-0132, Ext. 193

Dec. 7

00 (23-07872D)

EXHIBIT 2



TAMAYA
BETWEEN THE CITY AND THE SEA

Amenity Manager's Report



Prepared For

BEACH CDD

for the month of
December 2023

**Respectfully submitted by
Oliver Ingram**

EVENT SUMMARY

Date : November 11, 2023

Event: Coffee and Doughnuts for Veterans



Total Cost: \$20.97, donuts \$9.18 and coffee \$11.79

Attendance: 7 Attendees

Notes: Veterans were happy to be appreciated by the community.

EVENT SUMMARY

Date : November 12, 2023

Event: Story Time & Craft



Total Cost: 127.00

Attendance: 16-20 parents and children

Notes: Story time with Pat Kovacs The Great Thanksgiving Feast. Families enjoyed the story book reading, crafts and snacks.

EVENT SUMMARY

Date : November 17, 2023

Event: Friendsgiving Trivia



Total Cost: \$468.12

Attendance: 80 people

Notes: Always a hit for residents. Food & fun for everyone.

GATE USAGE REPORT

INFORMATION FROM TEK CONTROL FROM
NOVEMBER 15-DECEMBER 15, 2023

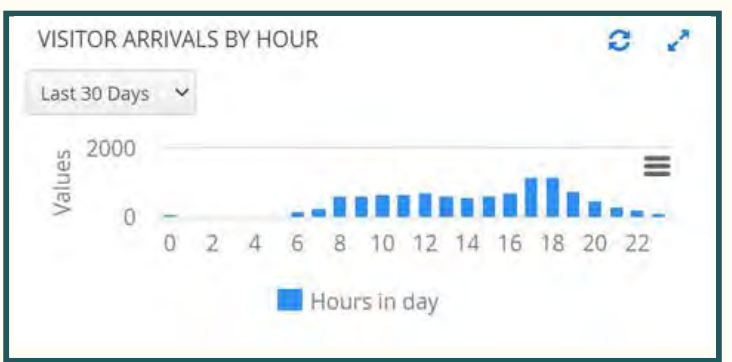
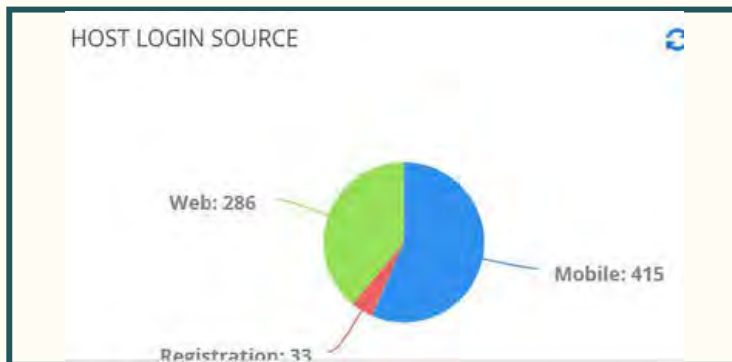
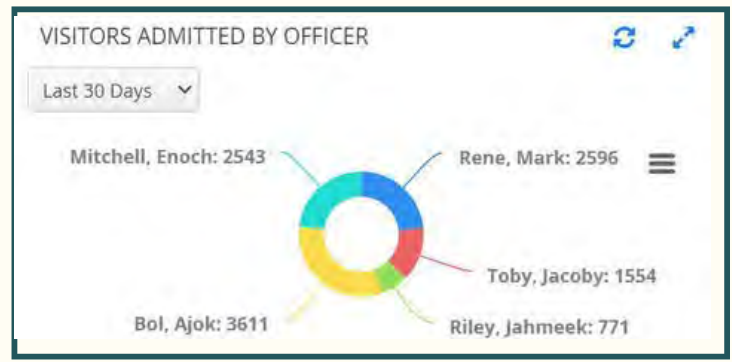
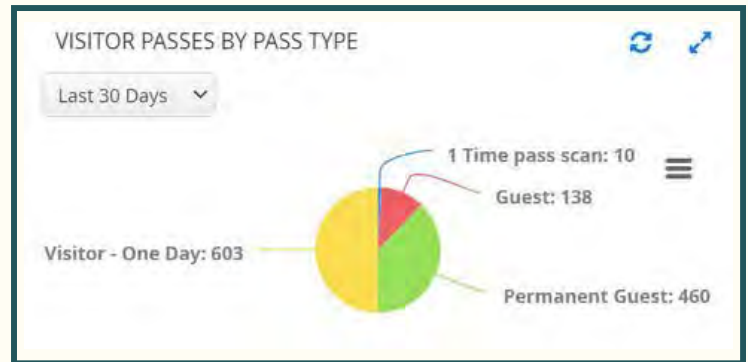

Visitor Arrivals: 357 Daily Average

Visitors and Passes added by officers: 9 Daily Average

SOCIAL CLUBS & PROGRAMMING

Social Clubs

- Lunch bunch
- Bible study
- Bunco
- Garden club
- Chapter Chatters
- Scrap Booking Club

Your paragraph text

Programming

- Strength, Balance and Flexibility With Emma
- Zumba with Tangie B- every Thursday 6:30-7:30 PM in the group fitness room

COMING SOON

January Events:

- 1/5/23 New Year's Kick off Bash
- 1/9/23 Special Events Meeting
- 1/13/23 Community Potluck
- 1/14/23 Story time & crafts
- 1/20/23 Movies on the lawn

February Events:

- 2/2/23 Tamaya Happy Hour
- 2/10/23 Residents customer car show
- 2/11/23 Story time & crafts
- 2/16/23 Trivia night
- 2/24/23 Movies on the lawn

March Events:

- 3/1/23 Tamaya Happy Hour
- 3/16/23 St. Patrick Day Party
- 3/23/23 Easter egg hunt event
- 3/30/23 Movies on the lawn

April Events:

- 4/5/23 Tamaya Happy Hour
- 4/27/23 Final Movies on the lawn for for the season
- More events will be announced soon

****Events subject to change****

Manager's Notes:

- CPR class scheduled for January for staff
- Special events resident feedback is scheduled for January 9
- Check-in windows for the gym and pool are in the final phase for completion
- New Cardio equipment has been installed at the gym

YTD Special Events Budget

Events Actual To Date
October 2023-2024

Remaining Budget \$26,488

	Oct-23	Nov-23	Dec-23	Jan-24	Feb-24	Mar-24	Apr-24	May-24	Jun-24	Jul-24	Aug-24	Sep-24	Total
Projected Monthly Events Budget	\$4,000	\$1,600	\$4,000	\$2,500	\$2,000	\$4,000	\$2,400	\$2,500	\$3,000	\$3,000	\$2,000	\$2,000	\$33,000
Actual Monthly Expenses	\$4,952	\$1,559											\$6,512
% To Budget	124%	97%	0%	0%	0%	0%	0%	0%	0%	0%	0%	0%	20%
Net \$ to Budget	(\$952)	\$41	\$4,000	\$2,500	\$2,000	\$4,000	\$2,400	\$2,500	\$3,000	\$3,000	\$2,000	\$2,000	\$26,488

2024 Approved Budget: \$33,000

2024 Approved Budget
\$33,000.00



If you have questions concerning this report please email oingram@vestapropertyservices.com.

EXHIBIT 3



Field Operations Managers' Report

Date of report: 12-11-2023

Submitted by: Ron Zastrocky

Field Operations Report

Landscape update

Beach CDD: Monthly Report November 2023 Fungus/Pest/Fertilizer: All landscape beds were sprayed with prosecutor herbicide to eliminate weed growth. A preemergent was applied as well, to prevent future weeds from growing in shrubs and landscape beds Maintenance: All turf at Beach CDD was serviced on a monthly basis. Ornamental grasses on Meritage Blvd have been cut down to promote a better growth in the spring. As we proceed through the winter months the turf will start to go dormant and lose its color. As we approach the spring, we will hit it hard with fertilizer and herbicide applications to ensure that it will be green and healthy for the summer months. Annuals: Fall annual maintenance was applied to flower beds. We added a granular fertilizer to promote color and health in the flowers. Irrigation Report: All irrigation is working as it should. We have had to replace a few heads and nozzles around the property. Notes: Annual flower switch out is the week of December 11th

Pond update

Completed Date: 12/8/2023 Target Pests (if applicable): Service Notes & Observations Treated and inspected ponds 1 - 11. Ponds 1, 2, 3, and 4 required shoreline treatments for emergent weeds. Algae is currently under control and ponds are excellent condition.

Completed Date: 12/8/2023 Target Pests (if applicable): Service Notes & Observations Treated Ponds 12-22 for various emergent vegetation. Please allow up to two weeks for full results

General Maintenance

- Pressure washed Tamaya Hall entrance.



- Pavers are done at mailbox kiosk.



- Gate arm complete at visitor lane at guardhouse.

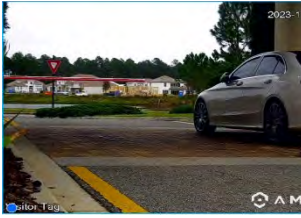

- Christmas lights put up



- AED machine put up in fitness center

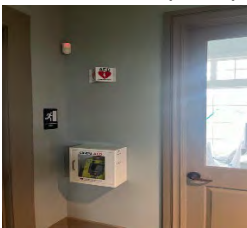

- Windows complete in fitness room office. Desk, chair and computer ordered.

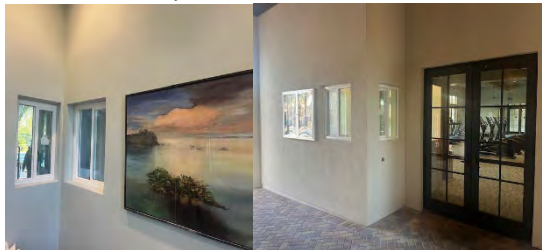

- New cardio equipment installed

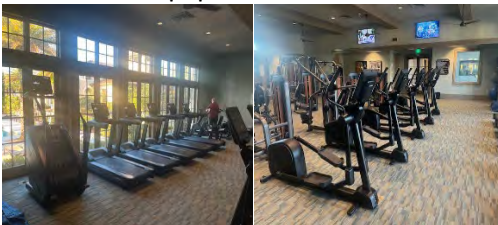

- Action item list update

Date of Action Item	Action Item	Status
4/17/2023	FOM to visit Durbin Crossing regarding pool lanes	Going there 12-14-23



7/17/2023	FOM to obtain quotes for beam over visitors entrance lane at guard house	Underway—FOM is going to install
7/17/2023	FOM to obtain quote for shade on playground.	Underway. Initial quote provided at 9/18 meeting. Guidance provided to staff regarding future quotes including drawings; also provide financing information when doing budget for FY 2025
9/18/2023	FOM to obtain quotes to have tree stakes removed from landscaping	10/16/2023: Tabled until 11/20 meeting for better direction; FOM has begun removing stakes near Tamaya Hall as time permits. Price from Tree Amigos is \$13.85 per stake to remove.
10/16/2023	FOM to obtain quotes for pool lighting replacement	Underway
10/16/2023	FOM to obtain quotes for Tamaya Blvd. lighting and pictures of areas covered by quotes	Underway. Seeking additional clarification from board due to cost as some of this property is not owned by the District.
11/20/2023	FOM to Take Pictures for Files for Sidewalk Repair on Savona Court	Signed proposal sent and waiting for repair date.
11/20/2023	FOM to get quotes to replace carpet in Tamaya Hall	See if carpet is needed.
11/20/2023	FOM to get quote for portable pressure washing machine	Under way to get proposal for 4200psi pressure washer and sidewalk scrubber. need more board direction on what all is included.
11/20/2023	FOM to establish schedule to pressure wash assets of the District	Underway

EXHIBIT 4



EXHIBIT 5

1 **MINUTES OF MEETING**

2 **BEACH**

3 **COMMUNITY DEVELOPMENT DISTRICT**

4 The Workshop of the Board of Supervisors of the Beach Community Development District was
5 held on Wednesday, October 25, 2023 at 6:00 p.m., at 12788 Meritage Blvd., Jacksonville, Florida 32246,
6 with Zoom Conference Call available.

7 **FIRST ORDER OF BUSINESS – Roll Call**

8 Mr. McInnes called the meeting to order and conducted roll call.

9 Present were:

10	Robert Renn	Board Supervisor, Vice Chairman
11	Sheila Papelbon	Board Supervisor, Assistant Secretary
12	Elena Korsakova	Board Supervisor, Assistant Secretary
13	David McInnes	District Manager, Vesta District Services
14	Dana Harden	Vesta Property Services
15	Oliver Ingram	Amenity Manager, Vesta Property Services
16	Brittany Bell	Operations Manager, Advanced Security
17	Jake Card	Advanced Security
18	Jim Kendig	Resident

19 *The following is a summary of the discussions at the October 25, 2023 Beach CDD Board of Supervisors*
20 *Workshop. Audio for this meeting is available upon public records request.*

21 **SECOND ORDER OF BUSINESS – Discussion Items**

22 **The board returned to this item after Exhibit 3.**

23 A. Exhibit 1: CDD Agreement to Allow HOA to Enforce No Parking on CDD Owned Streets

- 24 1. Exhibit 1A: Florida Statutes – Chapter 715
25 2. Agreement with CDD – Redline
26 3. Agreement with CDD – Clean

27 Mr. McInnes provided a brief explanation of the history behind this item. Discussion
28 ensued. Mr. Kendig provided comments.

29 B. Overnight Parking on Roadway – Make This a Violation of Amenity Policies

30 Supervisor Renn expressed his desire to remove towing from the discussion on overnight parking
31 and instead make it a violation of the amenity policies. Discussion ensued.

32 C. Vendor Scorecards

- 33 1. Exhibit 2A: Landscape Vendor Scorecard Example
34 2. Exhibit 2B: Vendor Scorecard Example

35 Supervisor Renn provided a brief explanation of the purpose for the scorecards and the
36 need for them. Discussion ensued regarding who would handle creation of scorecards and
37 who would evaluate the major vendors.

38 **This item was presented out of order before Exhibit 1.**

39 D. Exhibit 3: Advanced Security Issues

40 Ms. Bell gave a brief overview of the issues she had been monitoring within the community,
41 which included residents' use or lack thereof of the portal system in place for allowing people and
42 deliveries into the community. And, requested that post orders be created. Discussion ensued.

43 Discussion ensued regarding residents using the visitor gate.
44 Mr. Kendig noted that this was an ongoing discussion that he felt needed to finally be resolved
45 and a formal decision be made. Discussion ensued.
46 A resident asked about the construction entrance. Discussion ensued.
47 A resident asked if it was considered trespassing if a homeless person were to use the
48 community's pool to bathe in. Discussion ensued.
49 Discussion ensued regarding quarterly security training with the residents.
50 Ms. Bell asked if Advanced Security could sign contracts between themselves and residents when
51 providing security for resident run events. Discussion ensued.
52 Ms. Bell noted concerns she had regarding parking for the guards. Discussion ensued.
53 E. Placement of AED
54 Discussion ensued regarding the best possible location to place the AED.
55 F. Additional Testing of Pool Water
56
57 Discussion ensued regarding the recommendation to the Board to change the part of the Vesta
58 amenity services contract regarding pool water testing.
59
60 Discussion ensued regarding the frequency of workshops.

61 **THIRD ORDER OF BUSINESS – Adjournment**

62 The workshop meeting was adjourned at 8:53 p.m.
63 **Each person who decides to appeal any decision made by the Board with respect to any matter considered*
64 *at the meeting is advised that person may need to ensure that a verbatim record of the proceedings is made,*
65 *including the testimony and evidence upon which such appeal is to be based.*

66 **Meeting minutes were approved at a meeting by vote of the Board of Supervisors at a publicly noticed**
67 **meeting held on December 18, 2023.**

68
69

Signature

Signature

Printed Name

Printed Name

70 **Title:** **Secretary** **Assistant Secretary**

Title: **Chairman** **Vice Chairman**

EXHIBIT 6

1 **MINUTES OF MEETING**

2 **BEACH**

3 **COMMUNITY DEVELOPMENT DISTRICT**

4 The Regular Meeting of the Board of Supervisors of the Beach Community Development District
5 was held on Monday, November 20, 2023 at 6:00 p.m., at 12788 Meritage Blvd., Jacksonville, Florida
6 32246, with Zoom Conference Call available.

7 **FIRST ORDER OF BUSINESS – Roll Call**

8 Mr. McInnes called the meeting to order and conducted roll call.

9 Present and constituting a quorum were:

10	Matt Calderaro	Board Supervisor, Chairman
11	Robert Renn	Board Supervisor, Vice Chairman
12	Chance Wedderburn	Board Supervisor, Assistant Secretary
13	Elena Korsakova	Board Supervisor, Assistant Secretary

14 Also, present were:

15	David McInnes	District Manager, Vesta District Services
16	Dana Harden	Regional General Manager, Vesta Property Services
17	Ron Zastrocky	Field Operations Manager, Vesta Property Services
18	Brittany Bell	Advanced Security Specialist
19	Kyle Carasea	Tree Amigos
20	Wanda Boyd	Resident

21 *The following is a summary of the discussions and actions taken at the November 20, 2023 Beach CDD*
22 *Board of Supervisors Regular Meeting. Audio for this meeting is available upon public records request.*

23 **SECOND ORDER OF BUSINESS – Pledge of Allegiance**

24 Supervisor Calderaro led all present in reciting the Pledge of Allegiance.

25 **THIRD ORDER OF BUSINESS – Audience Comments** – *(limited to 3 minutes per individual for agenda*
26 *items)*

27 There being none, the next item followed.

28 **FOURTH ORDER OF BUSINESS – Exhibit 1: Presentation of Proof of Publication(s)**

29 **FIFTH ORDER OF BUSINESS – Vendor Reports**

30 A. Vesta Property Services

31 **The meeting moved to Exhibit 3 at this time.**

32 1. Exhibit 2: Lifestyle Management Report

33
34 Ms. Harden presented the report to the Board.

35
36 Supervisor Korsakova asked what the hourly cost was to have attendants in the breezeway,
37 what the need was for the number of employees, and requested that the newsletter be sent out
38 a week before the next month starts. And, noted that it was important to make the policies
39 easily accessible to residents. She also requested that there be an annual planning meeting to
40 consider events throughout the year and to allow for resident input and suggestions.
41 Discussion ensued.

42
43
44
45
46
47
48
49
50
51
52
53
54
55
56
57
58
59
60
61
62
63
64
65
66
67
68
69
70
71
72
73
74
75
76
77
78
79
80
81
82
83

Supervisor Renn noted that it would be a great idea to have a q&a session twice a year to gather feedback from the community on events and other such matters. And, suggested that the Chairman include a short letter to the residents in the newsletter to provide updates regarding CDD matters. Discussion ensued.

2. Exhibit 3: Field Management Report

Mr. Zastrocky presented the report to the Board. Discussion ensued regarding the possibility of replacing the carpets in Tamaya Hall

Supervisor Korsakova asked about adding a speed bump at the resident’s gate, cleaning of the roofs, inspection of the trimmed oaks on Meritage Blvd., the previously approved mailbox pavers, the events lawn, cleaning of the fountains, and replacement of the grass at Meritage Blvd.

Supervisor Renn asked for an update regarding the single sign in location, the installation of the new aerobics equipment, and pressure washing around the community. Discussion ensued.

The meeting moved back to Exhibit 2 at this time.

B. Advanced Security Specialist

Ms. Bell answered questions and provided comments. Discussion ensued.

C. Tree Amigos

Mr. Carasea presented the report to the Board. Discussion ensued.

Discussion ensued regarding Tree Amigos’ merger with Rupert Landscapes.

On a MOTION by Dr. Renn, SECONDED by Ms. Korsakova, WITH ALL IN FAVOR, the Board approved the review of Tree Amigos contract to make necessary changes and the authorization for the Chair to sign, for the Beach Community Development District.

SIXTH ORDER OF BUSINESS – Consent Agenda

A. Exhibit 4: Consideration for Approval – The Minutes of the Board of Supervisors Regular Meeting Held on October 16, 2023

B. Exhibit 5: Consideration for Acceptance – The Revised September 2023 Unaudited Financial Statements

C. Exhibit 6: Consideration for Acceptance – The October 2023 Unaudited Financial Statements

On a MOTION by Mr. Calderaro, SECONDED by Mr. Wedderburn, WITH ALL IN FAVOR, the Board approved the Consent agenda as presented, for the Beach Community Development District.

84 On a MOTION by Dr. Renn, SECONDED by Mr. Calderaro, WITH ALL IN FAVOR, the Board approved
85 the delay of the discussion to consider the transfer of parcels, for the Beach Community Development
86 District.

87 **SEVENTH ORDER OF BUSINESS – Business Items**

88 A. Consideration & Adoption of **Resolution 2024-02**, Tree Removal on CDD ROW

89 This item was not considered.

90 B. Exhibit 7: Consideration of Charles Aquatics Amenity Center Fountain Repair Proposal Options

91 Discussion ensued, but the decision was made to not repair.

92 C. Consideration of Amenity Center Fountain Replacement Proposal Options

93 Discussion ensued. No action was taken.

94 1. Exhibit 8: Charles Aquatics

95 2. Exhibit 9: Lake Doctors – *previously presented*

96 D. Exhibit 10: Consideration of Lucas Tree Dead Tree Cutting Behind Residents on Ostia Circle
97 Proposal

98 *The meeting recessed at 7:01PM.*

99 *The meeting reconvened at 7:06PM.*

100 Discussion ensued.

101 On a MOTION by Mr. Wedderburn, SECONDED by Dr. Renn, WITH ALL IN FAVOR, the Board
102 approved the Lucas Tree Dead Tree Cutting Behind Residents on Ostia Circle proposal, in the amount of
103 \$650.00, for the Beach Community Development District.

104 E. Consideration of Acceptance of Parcels from Developer

105 A motion was made earlier in the meeting to not consider these parcels at this time. This item was
106 tabled to the next meeting.

107 1. Exhibit 11: Proposed Parcel #1

108 2. Exhibit 12: Proposed Parcel #2

109 3. Exhibit 13: Proposed Parcel #3

110 4. Exhibit 14: Proposed Parcel #4

111 5. Exhibit 15: Proposed Parcel #5

112 6. Exhibit 16: Parcel Numbers 165284-6050 & 167067-0475

113 F. Consideration of All Weather Contractors Sidewalk Repair Proposals

114 Mr. McInnes provided a brief explanation for the proposals. Discussion ensued.

115 Mr. Haber noted that based on the memo he circulated there were some potential claims that were
116 available to the District to address the tree issue. He stated that the Board would need to make a
117 decision on how it wanted to do that. Further explaining that with the extent of the issues that were
118 arising throughout the community that were causing a risk and potential liability to the District,
119 then the Board had the right to fix those issues. He also noted on the record that by virtue of the
120 Board fixing it, or by virtue of the CDD fixing it, it was not for the purpose of accepting

121 responsibility for it, and they were reserving the right to make a claim for damages related to the
122 cost of fixing. But that the Board would be fixing it because they deemed it absolutely necessary
123 to address the liability issue. The other point Mr. Haber made was that when the Board was having
124 it fixed that they have someone there that would confirm the reason for the lifting of the sidewalk
125 was in fact a tree root and not some other reason such as settling or something like that. So just to
126 keep track of that, but to the extent that it was caused by a tree root, and the Board's fixing it to
127 remove the issue of liability, they could still preserve their ability to make a claim for it by stating
128 that they were doing it to fix the liability and not because they believe that they should be
129 responsible for it.

130 1. Exhibit 17: Savona Ct.

131 On a MOTION by Mr. Calderaro, SECONDED by Ms. Korsakova, WITH ALL IN FAVOR, the Board
132 approved the All-Weather Contractors Sidewalk Repair proposal, in the amount of \$1,770.00, for the Beach
133 Community Development District.

134 **The meeting moved to the District Counsel's report at this time.**

135 2. Exhibit 18: 1st Phase

136 This item was tabled until further notice.

137 Discussion ensued regarding the specifics of the sidewalk repairs.

138 G. Consideration of Holiday Lighting Proposal

139 On a MOTION by Mr. Wedderburn, SECONDED by Mr. Calderaro, WITH ALL IN FAVOR, the Board
140 approved the Holiday Lighting proposal, in the amount of \$10,026.00, for the Beach Community
141 Development District.

142 H. Exhibit 19: Consideration & Adoption of **Resolution 2024-03**, 2024 General Election

143 On a MOTION by Dr. Renn, SECONDED by Ms. Korsakova, WITH ALL IN FAVOR, the Board adopted
144 **Resolution 2024-03**, 2024 General Election, for the Beach Community Development District.

145 **EIGHTH ORDER OF BUSINESS – Discussion Items**

146 A. Discipline Process

147 Supervisor Korsakova provided a brief explanation on this topic. Discussion ensued. This item was
148 tabled until further notice.

149 **NINTH ORDER OF BUSINESS – Staff Reports**

150 A. District Counsel

151 **This item was presented out of order after Item F. 1 – Exhibit 17, under the Seventh**
152 **Order of Business, Business Items.**

153 1. Report on Research of Tree Issue

154 Mr. Haber provided a brief explanation on the memo he had previously circulated to the
155 Board. Discussion ensued.

156 **The meeting moved back to Item F. 2 – Exhibit 8, under the Seventh Order of**
157 **Business, Business Items, at this time.**

158 B. District Manager

- 159 1. Resident(s) Subject Disciplinary Action
160 Mr. McInnes briefed the Board on the resident who's amenity privileges were suspended.
161 2. Complaint & Incident Management Tracker
162 Mr. McInnes provided a brief update on this item.
163 3. Exhibit 20: Action Item Report
164 Discussion ensued.
165 4. Exhibit 21: Meeting Matrix
166 Mr. McInnes provided brief explanations regarding a few items and meetings on the
167 Meeting Matrix.
168 5. Exhibit 22: Memo to Board Regarding Items of Consensus from the 10/25/23 Workshop
169 Mr. McInnes provided a brief explanation regarding the Memo and the items on the
170 Memo. Discussion ensued.

171 On a MOTION by Dr. Renn, SECONDED by Mr. Calderaro, WITH ALL IN FAVOR, the Board approved
172 actions to be taken per the memo, for the Beach Community Development District.

173 Mr. McInnes requested that the newsletter that was created by Tree Amigos be
174 distributed to the community, and it was noted that that had already been done. He also
175 asked for the Board's consent to increase the email storage limit, which would take the
176 cost from \$10 per month per email address to \$18 per month per email address. The
177 Board consented to the cost increase and the subsequent increase in storage from 2GB to
178 12GB.

179 Mr. McInnes also brought up the discussion for the cost of roving patrol. Discussion
180 ensued.
181
182

183 6. Request for Clarification

184 a. Tree Stakes

185 Discussion ensued regarding the specifics of the request to remove the tree stakes,
186 such as the cost, locations, and number of tree stakes that needed to be removed.

187 b. Pressure Washing of Beach Blvd. Monument Fountain

188 Mr. McInnes notified the Board about a warning citation against the developer that
189 was dropped off at the CDD regarding the fountain on Beach Blvd.

190 C. District Engineer

191 The District Engineer was not present.

192 **TENTH ORDER OF BUSINESS – Supervisors' Requests**

193 Ms. Korsakova asked that Brettungar Dr. be added to the Property Appraiser's website as being
194 owned by the CDD. Clarification was provided that it was owned by the CDD, and that the Property
195 Appraiser had been informed of this prior but had not updated their website. She also made the
196 following requests: a conference call with the Trustee, that the Field Operations Manager obtain a
197 proposal to remove ornamental grasses from Cassia and Meritage to replace with sod, and that the
198 Field Operations Manager obtain a proposal to trim trees blocking sidewalks. Discussion ensued.

199 Mr. Wedderburn requested a scanner for QR codes and clicker/transponder for resident entry lane.

200 Discussion ensued regarding the Capital Reserves.

201 **ELEVENTH ORDER OF BUSINESS – Audience Comments – New Business/Non-Agenda** *(limited to*
202 *3 minutes per individual)*

203 Ms. Boyd noted a concern she had about the difficulties she had with entering the community as a
204 resident due to the gate arm not immediately recognizing that a vehicle was present, and asked if the
205 gate arm was the best possible option money wise. Discussion ensued.

206 **TWELFTH ORDER OF BUSINESS – Action Items Summary**

207 A copy of the Action Items Summary was available upon request.

208 **THIRTEENTH ORDER OF BUSINESS – Meeting Matrix Summary**

209 Workshop on trees.

210 Workshop on parking.

211 **FOURTEENTH ORDER OF BUSINESS – Next Meeting Quorum Check: December 18, 6:00 PM**

212 All Board members present indicated that they would attend the December 18, 2023, Board
213 meeting. Ms. Papelbon was not present to confirm.

214 **FIFTEENTH ORDER OF BUSINESS – Adjournment**

215 Mr. McInnes asked for final questions, comments, or corrections before requesting a motion to
216 adjourn the meeting. There being none, Dr. Renn made a motion to adjourn the meeting.

217 On a MOTION by Dr. Renn, SECONDED by Mr. Wedderburn, WITH ALL IN FAVOR, the Board
218 adjourned the meeting at 9:05 p.m. for the Beach Community Development District.

219 **Each person who decides to appeal any decision made by the Board with respect to any matter considered*
220 *at the meeting is advised that person may need to ensure that a verbatim record of the proceedings is made,*
221 *including the testimony and evidence upon which such appeal is to be based.*

222 **Meeting minutes were approved at a meeting by vote of the Board of Supervisors at a publicly noticed**
223 **meeting held on December 18, 2023.**

224
225
226
227

Signature

Signature

Printed Name

Printed Name

228 Title: Secretary Assistant Secretary

Title: Chairman Vice Chairman

EXHIBIT 7

Beach
Community Development District

Financial Statements
(Unaudited)

Preliminary

June 30, 2023

Beach CDD
Balance Sheet
June 30, 2023

	General Fund	Debt Service 2013A	Debt Service 2015A	Construction	Total
1 ASSETS					
2 OPERATING ACCOUNT BU	\$ 829,099	\$ -	\$ -	\$ -	\$ 829,099
3 PAYPAL ACCOUNT BU	100	-	-	-	100
4 CHECKING ACCOUNT CS	41,349	-	-	-	41,349
5 DEBT CARD ACCOUNT CS	893	-	-	-	893
6 DEBT SERVICE ACCOUNTS:					
7 SINKING FUND	-	-	-	-	-
8 INTEREST FUND	-	-	-	-	-
9 REDEMPTION FUND	-	37	-	-	37
10 PREPAYMENT FUND	-	48,832	25,435	-	74,268
11 REVENUE FUND	-	320,696	75,789	-	396,484
12 OP REDEMPTION FUND	-	-	-	-	-
13 ACQ & CONS 2013A	-	-	-	-	-
14 ACQ & CONS 2015A	-	-	-	-	-
15 ASSESSMENTS RECEIVABLE ON-ROLL	-	-	-	-	-
16 ASSESSMENTS RECEIVABLE OFF-ROLL	54,231	-	92,938	-	147,169
17 DUE FROM OTHER FUNDS	-	122,433	53,249	-	175,682
18 PREPAID	886	-	-	-	886
19 TOTAL ASSETS	\$ 926,558	\$ 491,999	\$ 247,411	\$ -	\$ 1,665,968
20 LIABILITIES					
21 ACCOUNTS PAYABLE	\$ 111,601	\$ -	\$ -	\$ -	\$ 111,601
22 DEFERRED REVENUE ON-ROLL	-	-	-	-	-
23 DEFERRED REVENUE OFF-ROLL	54,231	-	92,938	-	147,169
24 DUE TO OTHER FUNDS	175,682	-	-	-	175,682
25 OUTSTANDING CHECKS	-	-	-	-	-
26 TOTAL LIABILITIES	341,514	-	92,938	-	434,452
27 FUND BALANCE					
28 NONSPENDABLE					
29 PREPAID & DEPOSITS	886	-	-	-	886
30 CAPITAL RESERVES	109,319	-	-	-	109,319
31 OPERATING CAPITAL	-	-	-	-	-
32 UNASSIGNED	474,839	491,999	154,473	-	1,121,311
33 TOTAL FUND BALANCE	585,044	491,999	154,473	-	1,231,516
34 TOTAL LIABILITIES & FUND BALANCE	\$ 926,558	\$ 491,999	\$ 247,411	\$ -	\$ 1,665,968

Beach CDD
General Fund
Statement of Revenue, Expenditures, and Changes in Fund Balance
For the period from October 1, 2022 to June 30, 2023

	FY 2023 Adopted Budget	FY 2023 Month of June	FY 2023 Total Actual Year-to-Date	VARIANCE Over (Under) to Budget	% Actual YTD / FY Budget
1 REVENUE					
2 ASSESSMENTS ON-ROLL	\$ 1,402,321	\$ 7,687	\$ 1,408,715	\$ 6,395	100%
3 ASSESSMENTS OFF-ROLL	216,924	-	162,693	(54,231)	75%
4 INTEREST REVENUE	-	3	20	20	
5 OTHER FINANCING SOURCES	5,000	5,053	19,740	14,740	395%
6 CARRYFORWARD	-	-	-	-	
7 TOTAL REVENUE	\$ 1,624,245	\$ 12,744	\$ 1,591,168	\$ (33,077)	98%
8 EXPENDITURES					
9 GENERAL & ADMINISTRATIVE EXPENSES					
10 TRUSTEE FEES	\$ 8,000	\$ -	\$ 8,200	\$ 200	103%
11 SUPERVISOR FEES-REGULAR MEETINGS	10,000	-	5,800	(4,200)	58%
12 SUPERVISOR FEES-WORKSHOPS	2,000	-	2,400	400	120%
13 DISTRICT MANAGEMENT	42,000	2,700	31,500	(10,500)	75%
14 ENGINEERING	2,500	-	2,157	(343)	86%
15 DISSEMINATION AGENT	2,500	-	2,500	-	100%
16 DISTRICT COUNSEL	7,500	2,986	19,976	12,476	266%
17 ASSESSMENT ADMINISTRATION	5,500	458	4,125	(1,375)	75%
18 REAMORTIZATION SCHEDULE	-	-	-	-	
19 ARBITRAGE REBATE CALCULATION	-	-	5,850	5,850	
20 AUDIT	6,000	-	-	(6,000)	0%
21 WEBSITE	1,515	187	2,102	587	139%
22 LEGAL ADVERTISING	1,750	722	4,631	2,881	265%
23 DUES, LICENSES & FEES	175	-	175	-	100%
24 GENERAL LIABILITY INSURANCE	4,057	-	-	(4,057)	0%
25 PUBLIC OFFICIAL INSURANCE	2,895	-	-	(2,895)	0%
26 OFFICE MISCELLANEOUS	2,000	554	7,670	5,670	383%
27 TOTAL GENERAL & ADMINISTRATIVE EXPENSES	98,392	7,605	97,085	(1,307)	99%
28 FIELD EXPENSES					
29 FIELD MANAGEMENT	133,553	10,211	87,480	(46,073)	66%
30 PROPERTY INSURANCE	89,054	-	88,097	(957)	99%
31 LAKE MAINTENANCE	21,600	1,767	15,159	(6,441)	70%
32 LANDSCAPING (INCLUDING MATERIALS)	402,792	35,213	291,392	(111,400)	72%
33 IRRIGATION (REPAIRS)	10,000	-	4,933	(5,067)	49%
34 ELECTRIC - STREET LIGHTS/IRRIGATION-JEA	188,475	25,790	184,166	(4,309)	98%
35 RIGHT OF WAY / LAKE MOWING	2,500	-	-	(2,500)	0%
36 ENTRY WATER FEATURE	7,500	-	-	(7,500)	0%
37 CARRYFORWARD REPLENISH	-	-	-	-	
38 CONTINGENCY - HURRICANE / STORM CLEAN UP	8,000	-	-	(8,000)	0%
39 COMMUNITY MAINTENANCE	8,000	1,292	15,533	7,533	194%
40 CAPITAL IMPROVEMENTS	39,080	-	3,575	(35,505)	9%
41 TOTAL FIELD EXPENSES	910,554	74,273	690,336	(220,218)	76%

42	AMENITY EXPENSES					
43	AMENITY MANAGEMENT	154,556	13,539	88,072	(66,484)	57%
44	BREEZEWAY STAFF	-	-	1,035	1,035	
45	LIFEGUARD	-	7,997	10,145	10,145	
46	SWIMMING POOL CHEMICALS	-	360	13,040	13,040	
47	SWIMMING POOL INSPECTION	-	-	851	851	
48	AMENITY GENERAL MAINTENANCE & REPAIRS	21,510	1,972	11,048	(10,462)	51%
49	AMENITY CLEANING	-	650	11,823	11,823	
50	AMENITY ELECTRIC/WATER AND SEWER	60,000	4,416	37,231	(22,769)	62%
51	AMENITY GATES/CONTROL ACCESS	5,000	1,530	11,743	6,743	235%
52	AMENITY WEBSITE/COMPUTER EQUIPMENT	1,590	-	2,097	507	132%
53	AMENITY INTERNET/CABLE	10,000	1,127	10,185	185	102%
54	AMENITY DUES & LICENSES	850	-	459	(391)	54%
55	AMENITY SECURITY	800	2,783	8,483	7,683	1060%
56	FITNESS EQUIPMENT MAINTENANCE	10,000	-	1,437	(8,563)	14%
57	LIFESTYLES PROGRAMMING	25,000	3,593	20,243	(4,757)	81%
58	AMENITY GAS	600	47	513	(87)	85%
59	TENNIS COURT MAINTENANCE - 4 CLAY COURTS	14,500	5,950	13,187	(1,313)	91%
60	LANDSCAPING MAINTENANCE AMENITY CENTER	68,400	-	25,333	(43,067)	37%
61	LANDSCAPE IMPROVEMENT	2,500	-	-	(2,500)	0%
62	AMENITY IRRIGATION (REPAIRS)	1,500	-	-	(1,500)	0%
63	PEST CONTROL	1,200	115	1,005	(195)	84%
64	AMENITY FIRE SYSTEM MONITORING	1,500	75	1,481	(19)	99%
65	ALARM	500	-	-	(500)	0%
66	TRASH COLLECTION	2,292	178	1,637	(655)	71%
67	TOTAL AMENITY EXPENSES	382,298	44,330	271,048	(111,250)	71%
68	ACCESS CONTROL /GATE HOUSE					
69	GUARD SERVICE	222,400	18,900	178,470	(43,930)	80%
70	GUARD HOUSE SUPPLIES	800	-	551	(249)	69%
71	GUARD HOUSE UTILITIES	3,800	199	2,229	(1,571)	59%
72	GUARD HOUSE REPAIR & MAINTENANCE	1,000	(900)	2,233	1,233	223%
73	BAR CODE EXPENSE	5,000	-	2,464	(2,536)	49%
74	TOTAL ACCESS CONTROL/GATE HOUSE EXPENSES	233,000	18,199	185,947	(47,053)	80%
75	TOTAL EXPENDITURES	1,624,245	144,407	1,244,416	(379,829)	77%
76	EXCESS OF REVENUE OVER (UNDER) EXPENDITURES	-	(131,664)	346,752	346,752	
77	OTHER FINANCING SOURCES & USES					
78	TRANSFER IN	-	-	-	-	
79	TRANSFER OUT	-	-	-	-	
80	TOTAL OTHER FINANCING SOURCES & USES	-	-	-	-	
81	FUND BALANCE - BEGINNING	239,612		238,292	(1,320)	
82	NET CHANGE IN FUND BALANCE	-	(131,664)	346,752	346,752	
83	FUND BALANCE - ENDING	\$ 239,612		\$ 585,044	\$ 345,432	
84	ANALYSIS OF FUND BALANCE					
85	NONSPENDABLE					
86	PREPAID & DEPOSITS	886		886		
87	CAPITAL RESERVES	109,319		109,319		
88	OPERATING CAPITAL	-		-		
89	UNASSIGNED	129,407		474,839		
90	TOTAL FUND BALANCE	\$ 239,612		\$ 585,044		

Beach CDD
Debt Service 2013A
Statement of Revenue, Expenditures, and Changes in Fund Balance
For the period from October 1, 2022 to June 30, 2023

	FY 2023 Adopted Budget	FY 2023 Actual Year-to-Date	VARIANCE Over (Under) to Budget
1 REVENUE			
2 ASSESSMENTS ON-ROLL	\$ 800,640	\$ 801,848	\$ 1,208
3 INTEREST REVENUE	-	5,873	5,873
4 MISC. REVENUE	-	63,504	63,504
5 TOTAL REVENUE	800,640	871,225	70,585
6 EXPENDITURES			
7 INTEREST EXPENSE			
8 November 1, 2022	-	313,908	313,908
9 May 1, 2023	313,920	311,425	(2,495)
10 November 1, 2023	308,058	-	(308,058)
11 PRINCIPAL RETIREMENT			
12 May 1, 2023	175,000	175,000	-
PRINCIPAL PREPAYMENT	-	85,000	85,000
13 TOTAL EXPENDITURES	796,978	885,333	(88,355)
14 EXCESS OF REVENUE OVER (UNDER) EXPENDITURES	3,663	(14,107)	(17,770)
15 OTHER FINANCING SOURCES (USES)			
16 TRANSFER IN	-	37	37
17 TRANSFER OUT (USES)	-	-	-
18 TOTAL OTHER FINANCING SOURCES (USES)	-	37	37
19 FUND BALANCE - BEGINNING	496,223	506,069	9,846
20 NET CHANGE IN FUND BALANCE	3,663	(14,070)	(17,732)
21 FUND BALANCE - ENDING	\$ 499,886	\$ 491,999	\$ (7,887)

Beach CDD
Debt Service 2015A
Statement of Revenue, Expenditures, and Changes in Fund Balance
For the period from October 1, 2022 to June 30, 2023

	FY 2023 Adopted Budget	FY 2023 Actual Year-to-Date	VARIANCE Over (Under) to Budget
1 REVENUE			
2 ASSESSMENTS ON-ROLL	\$ 366,911	\$ 368,556	\$ 1,646
3 ASSESSMENTS OFF-ROLL	232,345	139,257	(93,087)
4 INTEREST REVENUE	-	316	316
5 MISC. REVENUE	-	22,196	22,196
6 TOTAL REVENUE	599,255	530,326	(68,929)
7 EXPENDITURES			
8 INTEREST EXPENSE			
9 November 1, 2022	-	221,988	221,988
10 May 1, 2023	221,988	221,988	-
11 November 1, 2023	217,268	-	(217,268)
12 PRINCIPAL RETIREMENT			
13 May 1, 2023	160,000	165,000	5,000
14 TOTAL EXPENDITURES	599,255	608,975	(9,720)
15 EXCESS OF REVENUE OVER (UNDER) EXPENDITURES	-	(78,649)	(78,649)
16 OTHER FINANCING SOURCES (USES)			
17 TRANSFER IN	-	149	149
18 TRANSFER OUT (USES)	-	-	-
19 TOTAL OTHER FINANCING SOURCES (USES)	-	149	149
20 FUND BALANCE - BEGINNING	96,818	232,972	136,154
21 NET CHANGE IN FUND BALANCE	-	(78,500)	(78,500)
22 FUND BALANCE - ENDING	\$ 96,818	\$ 154,473	\$ 57,655

Beach CDD Check Register - FY2023

Date	Ref. Num	Name	Memo	Deposits	Disbursements	Balance
09/30/2022		EOY Balance				295,536.89
10/01/2022	1114	Egis Insurance and Risk Advisors	FY Insurance Policy # 100122192 10/01/22-10/01/23		88,097.00	207,439.89
10/11/2022	1118	Kristin A. Robinson, MD	Refund of Deposit for rental of Pool Cabana		50.00	207,389.89
10/11/2022	100036	Advanced Security Specialist & Consulting	Invoice: T0092022A (Reference: Guard House Gate Access Management.)		8,370.00	199,019.89
10/11/2022	100037	Air Solutions Heating & Cooling Inc	Invoice: 0000094932 (Reference: Installed a new condenser fan motor, fan blade, and capacitor.)		2,038.39	196,981.50
10/11/2022	100038	Integrated Access Solutions	Invoice: 0001453 (Reference: Installation of Indoor Access Point.) Invoice: 0001472 (Referenc..		459.89	196,521.61
10/11/2022	100039	Life Fitness	Invoice: 7173030 (Reference: Clutch Kit.)		62.45	196,459.16
10/11/2022	100040	Southeast Fitness	Invoice: 100493 (Reference: Semi-annually scheduled preventative maintenance.)		640.00	195,819.16
10/11/2022	100041	Southeastern Paper Group	Invoice: 05717495 (Reference: Supplies.)		423.90	195,395.26
10/11/2022	100042	Staples	Invoice: 8067623768 (Reference: Office Supplies.)		48.07	195,347.19
10/11/2022	100043	Sun State Nursery & Landscaping, Inc	Invoice: 7821 (Reference: Irrigation Repairs.) Invoice: 7911 (Reference: Installation of Clock...		2,236.49	193,110.70
10/11/2022	100044	Wayne Automatic Fire Sprinklers Inc.	Invoice: 952684 (Reference: Annual Extinguisher Certification Inspection.)		352.61	192,758.09
10/14/2022	100045	10-S Tennis Supply & Dinkshot Pickleball	Invoice: 156365 (Reference: Aluminum Drag Broom.) Invoice: 156337 (Reference: 10-S Linesr		437.61	192,320.48
10/14/2022	100046	Advanced Security Specialist & Consulting	Invoice: T0092022B (Reference: Guard House Gate Access Management.) Invoice: TA0092022		12,570.00	179,750.48
10/14/2022	100047	Innersync	Invoice: 20817 (Reference: Website Services.)		1,515.00	178,235.48
10/14/2022	100048	Sun State Nursery & Landscaping, Inc	Invoice: 7986 (Reference: October Landscape Maintenance.)		35,213.10	143,022.38
10/14/2022	100050	The Lake Doctors, Inc.	Invoice: 36532B (Reference: Water Management Zone 1 & 2.)		1,395.00	141,627.38
10/14/2022	100051	Turner Pest Control	Invoice: 19160304 (Reference: Monthly pest control.)		104.74	141,522.64
10/14/2022	100052	Vesta Property Services	Invoice: 403326 (Reference: September Fees.)		19,605.00	121,917.64
10/14/2022	100053	VGlobal Tech	Invoice: 4366 (Reference: Email hosting.)		50.00	121,867.64
10/14/2022	101422ACH1	JEA	Service for the month of September		27,918.90	93,948.74
10/15/2022	101522ACH1	Comcast	12788 Meritace Blvd MINI MDTA 9/28/22 to 10/27/22		535.58	93,413.16
10/17/2022	1119	Dominik Guess	Refund for Rental Cancellation		200.00	93,213.16
10/17/2022	1120	Instant PhotoCube	80's Casino Night		475.00	92,738.16
10/17/2022	101722ACH1	Comcast	12750 Meritage Blvd. GATEHOUSE 9/30-10/29/22		212.20	92,525.96
10/18/2022	101822ACH1	TECO	12545 Beach Blvd - 8/19/22 - 9/20/22		37.07	92,488.89
10/20/2022			Deposit	1,749.54		94,238.43
10/21/2022	102122ACH1	Florida Natural Gas	Fuel and Inside FGT Z3 8/19/22 - 9/18/22		17.79	94,220.64
10/22/2022	102222ACH1	Comcast	12788 Meritage Blvd. OFC 4 10/3-11/2/22		351.09	93,869.55
10/23/2022	ACH 102322	Credit Card transactions			693.49	93,176.06
10/24/2022	100054	Advanced Security Specialist & Consulting	Invoice: T0102022A (Reference: Guard House Gate Access Management.)		8,100.00	85,076.06
10/24/2022	100055	Integrated Access Solutions	Invoice: 0001945 (Reference: Service call.) Invoice: 0001950 (Reference: Service Call.) In...		900.00	84,176.06
10/24/2022	100056	Life Fitness	Invoice: 7195361 (Reference: Seat Pad.)		117.75	84,058.31
10/24/2022	100057	Southeastern Paper Group	Invoice: 05660098 (Reference: Paper Supplies.)		355.77	83,702.54
10/24/2022	100058	Staples	Invoice: 8067869974 (Reference: Office Supplies.)		400.17	83,302.37
10/26/2022	100059	Integrated Access Solutions	Invoice: 0001465 (Reference: Labor for installation, setup and testing.)		360.00	82,942.37
10/27/2022	102722ACH1	Comcast	13077 Beach Blvd. PEDESTRIAN GATE 10/10 -11/9/22		194.35	82,748.02
10/31/2022			Service Charge		1.45	82,746.57
10/31/2022		EOM Balance		1,749.54	214,539.86	82,746.57
11/03/2022			Deposit	3,000.00		85,746.57
11/07/2022	100060	DPFG M&C	Invoice: 403568 (Reference: Dissemination Agent.) Invoice: 403505 (Reference: District Manag		6,458.33	79,288.24
11/07/2022	100061	Advanced Security Specialist & Consulting	Invoice: TA0102022 (Reference: Amenities security.) Invoice: T0102022B (Reference: Guard H		11,070.00	68,218.24
11/07/2022	100062	Big Z Pool Service, LLC	Invoice: 11382 (Reference: Comp Pool, VFD Drive.)		1,970.00	66,248.24
11/07/2022	100063	Custom Pump & Controls, Inc.	Invoice: 22-314-04 (Reference: QUARTERLY LIFT STATION INSPECTION.)		150.00	66,098.24
11/07/2022	100064	GFL Environmental	Invoice: UG0000080959 (Reference: Nov 01/22 - Nov 30/22.)		162.01	65,936.23
11/07/2022	100065	Integrated Access Solutions	Invoice: 0002027 (Reference: BAI Barcodes Black on Black.) Invoice: 0002035 (Reference: ped		1,740.01	64,196.22
11/07/2022	100066	Kutak Rock LLP	Invoice: 3126899 (Reference: General Counsel.)		1,320.00	62,876.22

11/07/2022	100067	Sun State Nursery & Landscaping, Inc	Invoice: 8275 (Reference: Irrigation Repairs.) Invoice: 8273 (Reference: Irrigation Repairs. ...		779.17	62,097.05
11/07/2022	100068	TEKWave Solutions LLC	Invoice: 102622- (Reference: VMS - November 2022.)		295.00	61,802.05
11/07/2022	100069	Turner Pest Control	Invoice: 19363970 (Reference: Commercial Pest Control.)		104.74	61,697.31
11/07/2022	100070	VGlobal Tech	Invoice: 4416 (Reference: Email hosting.)		50.00	61,647.31
11/07/2022	100071	Wayne Automatic Fire Sprinklers Inc.	Invoice: 998491 (Reference: Annual Sprinkler Inspection.)		309.38	61,337.93
11/14/2022	1121	Matthew Calderaro	BOS MTG 11/7/22		200.00	61,137.93
11/14/2022	1122	Robert Renn	BOS MTG 11/7/22		200.00	60,937.93
11/14/2022	1123	Shelia Papelbon	BOS MTG 11/7/22		200.00	60,737.93
11/14/2022	1124	Stefanos Kounoupas	BOS MTG 11/7/22		200.00	60,537.93
11/16/2022	111622ACH1	JEA	Service for the month of October		23,682.22	36,855.71
11/17/2022			Deposit	187,055.02		223,910.73
11/17/2022	111722ACH1	TECO	12545 Beach Blvd - 09/21/2022 to 10/20/2022		37.08	223,873.65
11/18/2022	111822ACH1	Comcast	12788 Meritace Blvd MINI MDTA 10/28/22 to 11/27/22		534.81	223,338.84
11/21/2022	ACH11/21/22	Florida Natural Gas	Fuel and Inside FGT Z3 9/20/22 -10/20/22		15.19	223,323.65
11/21/2022	1125	FLORIDA DEPT OF ECONOMIC OPPORTUNIT	FY 2022/2023 Special District Fee Invoice/Update Form		175.00	223,148.65
11/21/2022	100072	Integrated Access Solutions	Invoice: 0002123 (Reference: Emergency Service Call.)		180.00	222,968.65
11/21/2022	100073	Game Time Game Truck, LLC	Invoice: 3014 (Reference: 2 Hour Game Truck.)		504.00	222,464.65
11/21/2022	100074	DPFG M&C	Invoice: 404412 (Reference: District Management Services.)		3,958.33	218,506.32
11/21/2022	100075	Sun State Nursery & Landscaping, Inc	Invoice: 8366 (Reference: November Landscape Maintenance.) Invoice: 8274 (Reference: Irrigat		35,533.06	182,973.26
11/21/2022	100076	The Lake Doctors, Inc.	Invoice: 45252B (Reference: Water Management Zone 1 & 2.)		1,395.00	181,578.26
11/21/2022	112122ACH1	Comcast	12750 Meritage Blvd. GATEHOUSE10/30/22 to 11/29/22		211.88	181,366.38
11/22/2022			Deposit	54,231.04		235,597.42
11/23/2022			Deposit	192.36		235,789.78
11/23/2022	ACH 112322	Credit Card transactions			1,245.71	234,544.07
11/25/2022			Deposit	284,806.31		519,350.38
11/25/2022	112522ACH1	Comcast	12788 Meritage Blvd. OFC 4 11/3/22 - 12/2/22		351.09	518,999.29
11/30/2022	113022ACH1	Comcast	13077 Beach Blvd. PEDESTRIAN GATE 11/10/22 to 12/9/22		194.35	518,804.94
11/30/2022			Service Charge		1.70	518,803.24
11/30/2022	EOM Balance			529,284.73	93,228.06	518,803.24
12/02/2022	100077	Vesta Property Services	Invoice: 404248 (Reference: October Fees.)		20,846.14	497,957.10
12/05/2022			Deposit	1,346,682.83		1,844,639.93
12/06/2022			Deposit	1,950.00		1,846,589.93
12/06/2022			Deposit	215,761.07		2,062,351.00
12/12/2022	100078	10-S Tennis Supply & Dinkshot Pickleball	Invoice: 157124 (Reference: Pro-Screen Open Mesh.)		882.34	2,061,468.66
12/12/2022	100079	Advanced Security Specialist & Consulting	Invoice: T0112022A (Reference: Guard House Gate Access Management.)		9,300.00	2,052,168.66
12/12/2022	100080	Bob's Backflow & Plumbiong Services	Invoice: 87517 (Reference: Backflow Test.)		450.00	2,051,718.66
12/12/2022	100081	Integrated Access Solutions	Invoice: 0002199 (Reference: Wireless HDMI adapter.)		369.00	2,051,349.66
12/12/2022	100083	Kutak Rock LLP	Invoice: 113022-23-1 (Reference: General Counsel.)		4,558.50	2,046,791.16
12/12/2022	100084	Southeast Fitness	Invoice: 100363 (Reference: 9/6/2022 Diagnosis or Repair.)		150.00	2,046,641.16
12/12/2022	100085	Southeastern Paper Group	Invoice: 05773688 (Reference: ECO-AIR.)		53.32	2,046,587.84
12/12/2022	100086	Sun State Nursery & Landscaping, Inc	Invoice: 8551 (Reference: Fix Breaks on the back side of wall.) Invoice: 8550 (Reference: Irr...		36,036.41	2,010,551.43
12/12/2022	100087	TEKWave Solutions LLC	Invoice: 5414 (Reference: December 2022.)		295.00	2,010,256.43
12/12/2022	100088	The Lake Doctors, Inc.	Invoice: 670593 (Reference: Monthly Water Management Service.) Invoice: 57370b (Reference:		3,095.00	2,007,161.43
12/12/2022	100089	Turner Pest Control	Invoice: 19972952 (Reference: Pest Control.)		104.74	2,007,056.69
12/12/2022	100090	Vesta Property Services	Invoice: 405450 (Reference: November Fees.)		19,793.78	1,987,262.91
12/12/2022	100091	VGlobal Tech	Invoice: 4492 (Reference: Email hosting.)		50.00	1,987,212.91
12/12/2022	100092	The Perfect Pour	Invoice: 0000151A (Reference: Bar Service for Halloween Party 10/21/22.)		625.00	1,986,587.91
12/12/2022	100093	Daytona Beach News-Journal	Invoice: 0005017635 (Reference: Oct 1 - Oct 31, 2022.)		1,003.25	1,985,584.66
12/13/2022	1126	Matthew Calderaro	BOS MTG 12/5/22		200.00	1,985,384.66
12/13/2022	1127	Robert Renn	BOS MTG 12/5/22		200.00	1,985,184.66
12/13/2022	1128	Shelia Papelbon	BOS MTG 12/5/22		200.00	1,984,984.66
12/14/2022			Deposit	192.36		1,985,177.02

12/14/2022	121422ACH1	JEA	Service for the month of November		25,621.04	1,959,555.98
12/16/2022			Deposit	165,311.36		2,124,867.34
12/19/2022	121922ACH1	Comcast	12788 Meritace Blvd MINI MDTA 11/28/22 - 12/27/22		534.81	2,124,332.53
12/20/2022	122022ACH1	Comcast	12750 Meritage Blvd. GATEHOUSE11/30/22 to 12/29/22		211.88	2,124,120.65
12/20/2022	122022ACH2	TECO	12545 Beach Blvd - 10/20/2022 -11/28/22		37.70	2,124,082.95
12/22/2022	122222ACH1	Florida Natural Gas	Fuel and Inside FGT Z3 10/20/22 to 11/28/22		14.35	2,124,068.60
12/23/2022	100094	DPFG M&C	Invoice: 405570 (Reference: District Management Services.)		3,958.33	2,120,110.27
12/23/2022	100095	Advanced Security Specialist & Consulting	Invoice: TA0112022 (Reference: Amenities security.) Invoice: T0112022B (Reference: Guard H		11,460.00	2,108,650.27
12/23/2022	100096	Integrated Access Solutions	Invoice: 0002285 (Reference: Gate Repair.) Invoice: 0002291 (Reference: Guard House Gate Ac		3,192.16	2,105,458.11
12/23/2022	100097	Southeastern Paper Group	Invoice: 05765238 (Reference: Supplies.) Invoice: 05748187 (Reference: Supplies.)		824.54	2,104,633.57
12/23/2022	100098	Staples	Invoice: 8068566313 (Reference: Office Supplies.)		383.73	2,104,249.84
12/23/2022	100099	Vesta Property Services	Invoice: 403470 (Reference: Billable Expenses.)		3,170.38	2,101,079.46
12/23/2022	100100	Daytona Beach News-Journal	Invoice: 0005119397 (Reference: Advertising.)		1,324.92	2,099,754.54
12/23/2022	ACH 122322	Credit Card transactions			301.35	2,099,453.19
12/27/2022	1129	Matthew Calderaro	BOS MTG 12/19/22		200.00	2,099,253.19
12/27/2022	1130	Robert Renn	BOS MTG 12/19/22		200.00	2,099,053.19
12/27/2022	1131	Shelia Papelbon	BOS MTG 12/19/22		200.00	2,098,853.19
12/27/2022	1132	Stefanos Kounoupas	BOS MTG 12/19/22		200.00	2,098,653.19
12/27/2022	122722ACH1	Comcast	12788 Meritage Blvd. OFC 4 12/3/22 - 1/2/23		351.09	2,098,302.10
12/28/2022	1133	DPFG M&C	August Billable Expenses		30.63	2,098,271.47
12/30/2022			Deposit	308.38		2,098,579.85
12/30/2022	123022ACH1	Comcast	13077 Beach Blvd. PEDESTRIAN GATE 12/10/22 to 1/9/23		194.35	2,098,385.50
12/31/2022			Service Charge		1.75	2,098,383.75
12/31/2022	EOM Balance			1,730,206.00	150,625.49	2,098,383.75
01/03/2023	1135	Magnetix DJ Services	Reference: Emcee & DJ Polar Plunge. https://dpfg.payableslockbox.com/DocView/InvoiceViewer		400.00	2,097,983.75
01/03/2023	1136	Shannon Brooke Thomas	Reference: Halloween Paint and Sip Event. https://dpfg.payableslockbox.com/DocView/InvoiceVi		150.00	2,097,833.75
01/03/2023	1137	Art-Z-Faces, Inc.	Reference: Santa Appearance. <a "="" href="https://dpfg.payableslockbox.com/DocView/InvoiceViewer.aspx?i=">https://dpfg.payableslockbox.com/DocView/InvoiceViewer.aspx?i=		300.00	2,097,533.75
01/03/2023	100101	Advanced Security Specialist & Consulting	Invoice: T0122022A (Reference: Guard House Gate Access Management.)		9,000.00	2,088,533.75
01/03/2023	100102	Southeastern Paper Group	Invoice: 05783796 (Reference: Supplies.)		258.71	2,088,275.04
01/03/2023	100103	Vesta Property Services	Invoice: 404351 (Reference: Billable Expenses.)		2,894.83	2,085,380.21
01/03/2023	100104	Daytona Beach News-Journal	Invoice: 0005097697 (Reference: Advertising.)		14.83	2,085,365.38
01/04/2023			Deposit	875.00		2,086,240.38
01/05/2023	1140	BNY Mellon Tax Distributions	Tax Distributions 2013A		689,260.69	1,396,979.69
01/05/2023	1141	BNY Mellon Tax Distributions	Tax Distributions 2015A		316,807.18	1,080,172.51
01/06/2023			Deposit	79,101.86		1,159,274.37
01/09/2023			Deposit	54,231.04		1,213,505.41
01/09/2023	100105	Advanced Security Specialist & Consulting	Invoice: TA0122022 (Reference: Amenities security.) Invoice: T0122022B (Reference: Guard H		12,060.00	1,201,445.41
01/09/2023	100106	Bob's Backflow & Plumbiong Services	Invoice: 88072 (Reference: Backflow Test.)		227.49	1,201,217.92
01/09/2023	100107	Integrated Access Solutions	Invoice: 0002350 (Reference: Service Call.) Invoice: 0001921 (Reference: Comcast modem bad		272.00	1,200,945.92
01/09/2023	100108	Kutak Rock LLP	Invoice: 3158252 (Reference: General Counsel.)		1,092.50	1,199,853.42
01/09/2023	100109	Sun State Nursery & Landscaping, Inc	Invoice: 8943 (Reference: January Landscape Maintenance.)		35,213.10	1,164,640.32
01/09/2023	100110	TEKWave Solutions LLC	Invoice: 5467 (Reference: Community Visitor Management Software.)		295.00	1,164,345.32
01/09/2023	100111	The Lake Doctors, Inc.	Invoice: 63731B (Reference: Water Management.)		1,767.00	1,162,578.32
01/09/2023	100112	Turner Pest Control	Invoice: 20497453 (Reference: Commercial Pest Control.)		104.74	1,162,473.58
01/09/2023	100113	VGlobal Tech	Invoice: 4623 (Reference: Email hosting.)		50.00	1,162,423.58
01/09/2023	100114	Wayne Automatic Fire Sprinklers Inc.	Invoice: 1014988 (Reference: WayneNet Fire Alarm Monitoring.)		750.00	1,161,673.58
01/09/2023	100115	Oxi Fresh Carpet Cleaning	Invoice: 1050 (Reference: Tile and Grout & Carpet Cleaning.) Invoice: 1051 (Reference: Tile a.		2,355.25	1,159,318.33
01/09/2023	100116	Bouncers, Slides, and More Inc.	Invoice: 12152022.03 (Reference: Movie Night.) Invoice: 10082022.16 (Reference: Obstacle Cc		1,330.00	1,157,988.33
01/15/2023	11523ACH1	Comcast	12788 Meritace Blvd MINI MDTA 12/28/22 - 1/27/23		547.90	1,157,440.43
01/17/2023	11723ACH1	Comcast	12750 Meritage Blvd. GATEHOUSE12/30/22 to 1/29/23		215.97	1,157,224.46
01/17/2023	100117	DPFG M&C	Invoice: 404329 (Reference: October Billable Expenses.)		48.95	1,157,175.51
01/18/2023	11823ACH1	TECO	12545 Beach Blvd - 11/28/22 - 12/19/22		40.25	1,157,135.26

01/18/2023			Deposit	192.36		1,157,327.62
01/19/2023	11922ACH1	JEA	Service for the month of December		27,981.75	1,129,345.87
01/20/2023	100118	DPFG M&C	Invoice: 406418 (Reference: December Billable Expenses.) Invoice: 406478 (Reference: District		4,104.61	1,125,241.26
01/20/2023	100119	Integrated Access Solutions	Invoice: 0002427 (Reference: Labor for installation, setup and testing.)		899.63	1,124,341.63
01/20/2023	100121	Sun State Nursery & Landscaping, Inc	Invoice: 8548 (Reference: Irrigation Repairs made during Inspection.)		142.18	1,124,199.45
01/20/2023	100122	Coastal Maintenance M.E. LLC	Invoice: 4165 (Reference: Holiday Lights.)		5,578.00	1,118,621.45
01/22/2023	12223ACH1	Comcast	12788 Meritage Blvd. OFC 4 1/3/23 - 2/2/23		361.28	1,118,260.17
01/23/2023	ACH012323	Florida Natural Gas	Fuel and Inside FGT Z3 11/28/22 to 12/19/22		23.99	1,118,236.18
01/23/2023	1142	Chance Wedderburn	BOS MTG 1/16/23		200.00	1,118,036.18
01/23/2023	1143	Matthew Calderaro	BOS MTG 1/16/23		200.00	1,117,836.18
01/23/2023	1144	Robert Renn	BOS MTG 1/16/23		200.00	1,117,636.18
01/23/2023	1145	Shelia Papelbon	BOS MTG 1/16/23		200.00	1,117,436.18
01/23/2023	1151	Stefanos Kounoupas	BOS MTG 1/16/23		200.00	1,117,236.18
01/23/2023	ACH 012323	Credit Card transactions			908.87	1,116,327.31
01/24/2023	1152	Brian T. Shirley	Stand-Up Comedy Show for Valentine's Day Cocktail Party		400.00	1,115,927.31
01/24/2023	1153	Ebony Lunsford	Cocktail Service		500.00	1,115,427.31
01/24/2023			Deposit	127,429.74		1,242,857.05
01/25/2023	100123	Advanced Security Specialist & Consulting	Invoice: T0012023A (Reference: Guard House Gate Access Management.)		9,300.00	1,233,557.05
01/25/2023	100124	Custom Pump & Controls, Inc.	Invoice: 23-314-01 (Reference: QUARTERLY LIFT STATION INSPECTION.)		150.00	1,233,407.05
01/25/2023	100125	E.T.M.	Invoice: 0206237 (Reference: Engineering Services.)		1,073.25	1,232,333.80
01/25/2023	100126	GFL Environmental	Invoice: UG0000087355 (Reference: Trash Service.)		193.73	1,232,140.07
01/25/2023	100127	Southeastern Paper Group	Invoice: 05806313 (Reference: PURELL HAND SANITIZING.)		175.71	1,231,964.36
01/25/2023	100128	Sun State Nursery & Landscaping, Inc	Invoice: 9019 (Reference: Irrigation Repairs Made During Monthly Inspection.)		151.79	1,231,812.57
01/25/2023	100129	Vesta Property Services	Invoice: 406387 (Reference: Billable Expenses.)		2,193.93	1,229,618.64
01/25/2023	100130	Daytona Beach News-Journal	Invoice: 0005202822 (Reference: Advertising.)		578.28	1,229,040.36
01/27/2023	1154	BNY Mellon Payment/Trustee Fees	Trustee Fees 2013A: November 01, 2022 to October 31, 2023		4,100.00	1,224,940.36
01/27/2023	1155	BNY Mellon Payment/Trustee Fees	Trustee Fees 2015A: November 01, 2022 to October 31, 2023		4,100.00	1,220,840.36
01/27/2023			Deposit	1,975.00		1,222,815.36
01/30/2023	1156	Magnetix DJ Services	Reference: Emcee & DJ Member Music Bingo Night		350.00	1,222,465.36
01/30/2023	13023ACH1	Comcast	13077 Beach Blvd. PEDESTRIAN GATE Jan 10, 2023 to Feb 09, 2023		199.35	1,222,266.01
01/31/2023			Service Charge		2.55	1,222,263.46
01/31/2023		EOM Balance		263,805.00	1,139,925.29	1,222,263.46
02/09/2023			Deposit	192.36		1,222,455.82
02/09/2023	100131	Advanced Security Specialist & Consulting	Invoice: T0012023B (Reference: Guard House Gate Access Management.)		9,600.00	1,212,855.82
02/09/2023	100132	Kutak Rock LLP	Invoice: 3170780 (Reference: General Counsel.)		1,897.50	1,210,958.32
02/09/2023	100133	Southeastern Paper Group	Invoice: 05817499 (Reference: Paper Supplies.)		297.63	1,210,660.69
02/09/2023	100134	Sun State Nursery & Landscaping, Inc	Invoice: 9158 (Reference: Valve Replacement.) Invoice: 9159 (Reference: Repair of break.) ...		36,225.90	1,174,434.79
02/09/2023	100135	TEKWave Solutions LLC	Invoice: 5523 (Reference: Visitor Management Software-JAN.)		295.00	1,174,139.79
02/09/2023	100136	The Lake Doctors, Inc.	Invoice: 72574B (Reference: Water Management.)		1,767.00	1,172,372.79
02/09/2023	100137	Turner Pest Control	Invoice: 20597624 (Reference: Pest Control.)		115.21	1,172,257.58
02/09/2023	100138	VGlobal Tech	Invoice: 4735 (Reference: Email:Email hosting.)		50.00	1,172,207.58
02/09/2023	100139	Community Advisors, LLC	Invoice: 1537 (Reference: Reserve Analysis.)		4,900.00	1,167,307.58
02/13/2023	100140	GFL Environmental	Invoice: UG000090424 (Reference: Trash Service.)		177.88	1,167,129.70
02/15/2023	21523ACH1	JEA	Service for the month of January		20,109.16	1,147,020.54
02/17/2023			Deposit	9,913.18		1,156,933.72
02/21/2023	22123ACH1	Comcast	12788 Meritace Blvd MINI MDTA 1/28/22 - 2/27/23		548.46	1,156,385.26
02/21/2023	22123ACH2	Comcast	12750 Meritage Blvd. GATEHOUSE1/30/23 to 2/28/23		216.20	1,156,169.06
02/21/2023	22123ACH3	TECO	12545 Beach Blvd - 12/20/22 - 1/23/23		56.44	1,156,112.62
02/23/2023	100141	Integrated Access Solutions	Invoice: 0002621 (Reference: Service Call.)		264.00	1,155,848.62
02/23/2023	100142	Southeastern Paper Group	Invoice: 05802879 (Reference: Paper Supplies.)		386.21	1,155,462.41
02/23/2023	100143	Vesta Property Services	Invoice: 406329 (Reference: December Fees.) Invoice: 405487 (Reference: Billable Expenses.)		46,194.31	1,109,268.10
02/23/2023	22323ACH1	Florida Natural Gas	Fuel and Inside FGT Z3 12/19/22 - 1/23/23		42.56	1,109,225.54

02/23/2023	ACH 022323	Credit Card transactions		1,977.35	1,107,248.19
02/27/2023	100144	DPFG M&C	Invoice: 407496 (Reference: January Billable Expenses.) Invoice: 407582 (Reference: District ...	4,066.06	1,103,182.13
02/27/2023	100145	Advanced Security Specialist & Consulting	Invoice: T0022023A (Reference: Guard House Gate Access Management.) Invoice: TA0012023	10,980.00	1,092,202.13
02/27/2023	100146	Bob's Backflow & Plumbing Services	Invoice: 89479 (Reference: Backflow Test.)	225.00	1,091,977.13
02/27/2023	100147	GFL Environmental	Invoice: UG0000093668 (Reference: Trash Service.)	177.88	1,091,799.25
02/27/2023	100148	Integrated Access Solutions	Invoice: 0002655 (Reference: BAI Barcodes Black on Black.)	383.78	1,091,415.47
02/27/2023	100149	Sun State Nursery & Landscaping, Inc	Invoice: 9472 (Reference: Irrigation Repairs made during Inspection.)	493.19	1,090,922.28
02/27/2023	100150	Turner Pest Control	Invoice: 20704326 (Reference: Pest Control.)	115.21	1,090,807.07
02/27/2023	100151	Vesta Property Services	Invoice: 407489 (Reference: Billable Expenses.)	592.85	1,090,214.22
02/27/2023	1157	Chance Wedderburn	BOS MTG 2/20/23	200.00	1,090,014.22
02/27/2023	1158	Matthew Calderaro	BOS MTG 2/20/23	200.00	1,089,814.22
02/27/2023	1159	Robert Renn	BOS MTG 2/20/23	200.00	1,089,614.22
02/27/2023	1160	Shelia Papelbon	BOS MTG 2/20/23	200.00	1,089,414.22
02/27/2023	1161	Stefanos Kounoupas	BOS MTG 2/20/23	200.00	1,089,214.22
02/27/2023		Deposit		1,375.00	1,090,589.22
02/27/2023		Deposit		3,297.16	1,093,886.38
02/28/2023		Service Charge		1.40	1,093,884.98
02/28/2023	EOM Balance			14,777.70	143,156.18
03/01/2023	ACH030123	Bank United	Check 126 deposited 02/27 Chargeback Fee	35.00	1,093,849.98
03/02/2023	030223ACH1	Comcast	13077 Beach Blvd. PEDESTRIAN GATE 2/10/23 - 3/9/23	199.35	1,093,650.63
03/03/2023	1162	Live Entertainment Solutions, LLC	DJ for Trivia Night on 3/16/23 including supplies	275.00	1,093,375.63
03/06/2023		Deposit		6,849.03	1,100,224.66
03/08/2023		Deposit		192.36	1,100,417.02
03/09/2023	100152	Advanced Security Specialist & Consulting	Invoice: TA0022023 (Reference: Amenities security.) Invoice: T0022023B (Reference: Guard H	9,960.00	1,090,457.02
03/09/2023	100153	Kutak Rock LLP	Invoice: 3182997 (Reference: General Counsel.)	1,901.50	1,088,555.52
03/09/2023	100154	TEKWave Solutions LLC	Invoice: 5578 (Reference: Visitor Management Software.)	295.00	1,088,260.52
03/09/2023	100155	First Coast Mulch	Invoice: 4831 (Reference: Mulch Installation:Playground Chips.)	3,575.00	1,084,685.52
03/13/2023	100156	Southeastern Paper Group	Invoice: 05829171 (Reference: Supplies.)	376.43	1,084,309.09
03/13/2023	100157	Sun State Nursery & Landscaping, Inc	Invoice: 9616 (Reference: March Landscape Maintenance.)	35,213.10	1,049,095.99
03/13/2023	100158	The Lake Doctors, Inc.	Invoice: 76968B (Reference: Water Management.)	1,767.00	1,047,328.99
03/13/2023	100159	Vesta Property Services	Invoice: 408152 (Reference: Amenity Management.)	18,973.93	1,028,355.06
03/13/2023	100160	VGlobal Tech	Invoice: 4781 (Reference: Email hosting.)	50.00	1,028,305.06
03/13/2023	100161	Wayne Automatic Fire Sprinklers Inc.	Invoice: 1030521 (Reference: Annual Extinguisher Certification Inspection.) Invoice: 1030371 .	346.73	1,027,958.33
03/14/2023	1163	Matthew Calderaro	BOS MTG 3/09/23	200.00	1,027,758.33
03/14/2023	1164	Stefanos Kounoupas	BOS MTG 3/9/23	200.00	1,027,558.33
03/16/2023		Deposit		61,862.73	1,089,421.06
03/17/2023	31723ACH1	JEA	Service for the month of February	18,352.18	1,071,068.88
03/20/2023	ACH032023	TECO	12545 Beach Blvd - 1/24/23 - 2/21/23	41.09	1,071,027.79
03/20/2023	032023ACH1	Comcast	12750 Meritage Blvd. GATEHOUSE 3/01/23 to 3/29/23	216.20	1,070,811.59
03/20/2023	32023ACH2	Comcast	12788 Meritace Blvd MINI MDTA 2/28/22 - 3/27/23	548.42	1,070,263.17
03/23/2023	ACH032323	Florida Natural Gas	Fuel and Inside FGT Z3 1/23/23 - 2/21/23	16.08	1,070,247.09
03/23/2023	100162	DPFG M&C	Invoice: 408425 (Reference: District Management Services.) Invoice: 408367 (Reference: Billab	4,224.33	1,066,022.76
03/23/2023	100163	Advanced Security Specialist & Consulting	Invoice: T0032023A (Reference: Guard House Gate Access Management.)	9,000.00	1,057,022.76
03/23/2023	100165	Vesta Property Services	Invoice: 408342 (Reference: Billable Expenses.)	603.48	1,056,419.28
03/23/2023	ACH 032323	Credit Card transactions		2,530.22	1,053,889.06
03/27/2023	22723ACH1	Comcast	12788 Meritage Blvd. OFC 4 2/3/23 - 3/2/23	361.29	1,053,527.77
03/27/2023	1165	Chance Wedderburn	BOS MTG 3/20/23	200.00	1,053,327.77
03/27/2023	1166	Matthew Calderaro	BOS MTG 3/20/23	200.00	1,053,127.77
03/27/2023	1167	Robert Renn	BOS MTG 3/20/23	200.00	1,052,927.77
03/27/2023	1168	Shelia Papelbon	BOS MTG 3/20/23	200.00	1,052,727.77
03/27/2023	100166	GFL Environmental	Invoice: UG0000096764 (Reference: Trash Service.)	195.31	1,052,532.46
03/27/2023	100167	Integrated Access Solutions	Invoice: 0002826 (Reference: Installation, set-up & testing.)	1,383.00	1,051,149.46

03/27/2023	032723ACH1	Comcast	12788 Meritage Blvd. OFC 4 3/3/23 - 4/2/23		361.24	1,050,788.22
03/28/2023			Deposit	600.00		1,051,388.22
03/30/2023	030323ACH1	Comcast	13077 Beach Blvd. PEDESTRIAN GATE Mar 10, 2023 to Apr 09, 2023		199.35	1,051,188.87
03/31/2023	100168	Bob's Backflow & Plumbiong Services	Invoice: 90342 (Reference: replace the existing backflow preventer.)		1,597.00	1,049,591.87
03/31/2023	100169	Southeastern Paper Group	Invoice: 05856941 (Reference: Paper Supplisr.) Invoice: 05853072 (Reference: Paper Supplies.		423.65	1,049,168.22
03/31/2023	100170	Sun State Nursery & Landscaping, Inc	Invoice: 9802 (Reference: Irrigation Repairs.)		925.95	1,048,242.27
03/31/2023	100171	TEKWave Solutions LLC	Invoice: 5632 (Reference: VMS - APRIL.)		295.00	1,047,947.27
03/31/2023	100172	Turner Pest Control	Invoice: 617040310 ()		115.21	1,047,832.06
03/31/2023	100173	Beaches Electrical Service, Inc.	Invoice: 11802 (Reference: Service Call.)		187.50	1,047,644.56
03/31/2023			Service Charge		1.80	1,047,642.76
03/31/2023		EOM Balance		69,504.12	115,746.34	1,047,642.76
04/03/2023	1169	Weinglass Music	Musician 4/13/23		500.00	1,047,142.76
04/06/2023	100174	Advanced Security Specialist & Consulting	Invoice: TA0032023 (Reference: Amenities security.) Invoice: T0032023B (Reference: Guard H		12,330.00	1,034,812.76
04/06/2023	100175	Integrated Access Solutions	Invoice: 0002866 (Reference: Service call response to check Amenity NVR HDD.) Invoice: 000.		528.00	1,034,284.76
04/06/2023	100176	Life Fitness	Invoice: 7337480 (Reference: Parts.) Invoice: 7336389 (Reference: Parts.)		46.86	1,034,237.90
04/06/2023	100177	Southeast Fitness	Invoice: 101452 (Reference: Semi-annually scheduled preventative maintenance.)		640.00	1,033,597.90
04/06/2023	100178	Sun State Nursery & Landscaping, Inc	Invoice: 9947 (Reference: April Landscape Maintenance.)		35,213.10	998,384.80
04/06/2023	100179	The Lake Doctors, Inc.	Invoice: 84489B (Reference: Water Management.)		1,767.00	996,617.80
04/11/2023			Deposit	192.36		996,810.16
04/11/2023			Deposit	18,840.21		1,015,650.37
04/14/2023	100180	Custom Pump & Controls, Inc.	Invoice: 23-314-02 (Reference: QUARTERLY LIFT STATION INSPECTION.)		150.00	1,015,500.37
04/14/2023	100181	Integrated Access Solutions	Invoice: 0002934 (Reference: Main Control Board & Liftmaster Motor.)		1,308.91	1,014,191.46
04/14/2023	100182	Kutak Rock LLP	Invoice: 3197846 (Reference: Beach CDD - General Counsel.)		3,028.00	1,011,163.46
04/14/2023	100183	Southeastern Paper Group	Invoice: 05870004 (Reference: Supplies.)		568.49	1,010,594.97
04/14/2023	100184	Vesta Property Services	Invoice: 409165 (Reference: Amenity Management.) Invoice: 409239 (Reference: Billable Expe		21,301.36	989,293.61
04/14/2023	100185	VGloba Tech	Invoice: 4929 (Reference: Email hosting.)		50.00	989,243.61
04/14/2023	100186	JT's Home Solutions LLC	Invoice: 197 (Reference: Touch up painting - Fitness Room.)		750.00	988,493.61
04/17/2023	0417ACH1	JEA	Service for the month of March		21,430.34	967,063.27
04/18/2023	1170	The Perfect Pour	Event at Tamaya 4/13/23		450.00	966,613.27
04/18/2023	0418ACH1	Comcast	12788 Meritace Blvd MINI MDTA 3/28/22 - 4/27/23		548.42	966,064.85
04/19/2023	0419ACH1	TECO	12545 Beach Blvd - 2/22/23 - 3/22/23		36.35	966,028.50
04/19/2023			Deposit	3,451.56		969,480.06
04/20/2023			Deposit	54,231.04		1,023,711.10
04/20/2023	Wire042023	BNY Mellon Payment/Trustee Fees	Off Roll Assessment 2015A-1		139,418.70	884,292.40
04/20/2023	0420ACH1	Comcast	12750 Meritage Blvd. GATEHOUSE 3/30/23 - 4/29/23		216.20	884,076.20
04/20/2023			Deposit	139,406.70		1,023,482.90
04/21/2023	ACH042123	Florida Natural Gas	Fuel and Inside FGT Z3 2/23/23 - 3/22/23		10.23	1,023,472.67
04/24/2023	1171	Chance Wedderburn	BOS MTG 4/17/23		200.00	1,023,272.67
04/24/2023	1172	Matthew Calderaro	BOS MTG 4/17/23		200.00	1,023,072.67
04/24/2023	1173	Robert Renn	BOS MTG 4/17/23		200.00	1,022,872.67
04/24/2023	100187	Advanced Security Specialist & Consulting	Invoice: T0042023A (Reference: Guard House Gate Access Management.)		9,000.00	1,013,872.67
04/24/2023	100188	Big Z Pool Service, LLC	Invoice: 12240 (Reference: warranty sump pumps.)		392.00	1,013,480.67
04/24/2023	100189	Integrated Access Solutions	Invoice: 0002962 (Reference: Service Call Driveway resident entry barrier arm.) Invoice: 0002...		954.14	1,012,526.53
04/24/2023	100190	B.A.B Tennis Courts	Invoice: 1 (Reference: Tennis Center Resurfacing Project.)		5,950.00	1,006,576.53
04/24/2023	100191	Vesta District Services	Invoice: 409333 (Reference: District Management Services.)		3,958.33	1,002,618.20
04/24/2023	ACH 042423	Credit Card transactions			2,026.15	1,000,592.05
04/25/2023	0425ACH1	Comcast	12788 Meritage Blvd. OFC 4 4/3/23 - 5/2/23		361.24	1,000,230.81
04/27/2023			Deposit	1,320.00		1,001,550.81
04/30/2023			Service Charge		2.85	1,001,547.96
04/30/2023		EOM Balance		217,441.87	263,536.67	1,001,547.96
05/01/2023	1174	Chance Wedderburn	BOS Workshop 4/26/23		200.00	1,001,347.96
05/01/2023	1175	Matthew Calderaro	BOS Workshop 4/26/23		200.00	1,001,147.96

05/01/2023	1176	Robert Renn	BOS Workshop 4/26/23		200.00	1,000,947.96
05/01/2023	0501ACH1	Comcast	13077 Beach Blvd. PEDESTRIAN GATE Apr 09, 2023 to May 10, 2023		199.35	1,000,748.61
05/02/2023			Deposit	661.00		1,001,409.61
05/04/2023	100192	Magnetix DJ Services	Invoice: 3513 (Reference: Emcee & DJ Member Trivia Night.)		350.00	1,001,059.61
05/04/2023			Deposit	18,233.94		1,019,293.55
05/05/2023	100193	Advanced Security Specialist & Consulting	Invoice: T0042023B (Reference: Guard House Gate Access Management.) Invoice: TA0042023		11,520.00	1,007,773.55
05/05/2023	100194	Integrated Access Solutions	Invoice: 0003005 (Reference: Service Call.) Invoice: 0003024 (Reference: Service Call - Fitne...		411.00	1,007,362.55
05/05/2023	100195	Kutak Rock LLP	Invoice: 3211113 (Reference: General Counsel.)		1,938.00	1,005,424.55
05/05/2023	100196	TEKWave Solutions LLC	Invoice: 5684 (Reference: Visitor Management Software.)		295.00	1,005,129.55
05/05/2023	100197	The Lake Doctors, Inc.	Invoice: 91916B (Reference: Water Management.)		1,767.00	1,003,362.55
05/05/2023	100198	VGlobel Tech	Invoice: 5000 (Reference: Email hosting.)		50.00	1,003,312.55
05/05/2023	100199	SS Live Entertainment, LLC	Invoice: 2854 (Reference: Live Entertainment 4.22.23.)		500.00	1,002,812.55
05/05/2023	100200	Bouncers, Slides, and More Inc.	Invoice: 042423- (Reference: Bounce House & Obstacle Course.)		500.00	1,002,312.55
05/05/2023	100201	Beaches Electrical Service, Inc.	Invoice: 11957 (Reference: Service call on Fountain.)		125.00	1,002,187.55
05/05/2023	100202	Vesta District Services	Invoice: 409273 (Reference: Billable Expenses - March 2023.)		127.76	1,002,059.79
05/10/2023	01ACH051023	Florida Department of Health	Pool permit 16-60-1627485		325.35	1,001,734.44
05/10/2023	02ACH051023	Florida Department of Health	Pool permit 16-60-1627490		325.35	1,001,409.09
05/10/2023	03ACH051023	Florida Department of Health	Pool permit16-60-1679058		200.35	1,001,208.74
05/10/2023	0510ACH1	GFL Environmental	Trash Service		195.31	1,001,013.43
05/11/2023			Deposit	192.36		1,001,205.79
05/12/2023	1177	TEKWave Solutions LLC			1,180.00	1,000,025.79
05/12/2023	100203	Buehler Air Conditioning	Invoice: 106529 (Reference: Service Call.)		491.10	999,534.69
05/12/2023	100204	Jacksonville Daily Record	Invoice: 050423- (Reference: Advertising Supervisors Meeting.) Invoice: 041323- (Reference: .		282.76	999,251.93
05/12/2023	100205	Southeastern Paper Group	Invoice: 05895051 (Reference: Supplies.)		512.01	998,739.92
05/12/2023	100206	Sun State Nursery & Landscaping, Inc	Invoice: 10106 (Reference: Irrigation Repairs during Inspection.)		284.75	998,455.17
05/12/2023	100207	Vesta Property Services	Invoice: 410072 (Reference: Amenity Management.) Invoice: 410012 (Reference: Billable Expe		20,729.65	977,725.52
05/12/2023	100208	SS Live Entertainment, LLC	Invoice: 2860 (Reference: Live Entertainment 5/28 & 5/29/23.)		1,000.00	976,725.52
05/12/2023	100209	Trice Music Services, Inc.	Invoice: 00515 (Reference: Entertainment - May 27th.)		375.00	976,350.52
05/15/2023	1178	Chance Wedderburn	BOS Workshop 5/10/23		200.00	976,150.52
05/15/2023	1179	Matthew Calderaro	BOS Workshop 5/10/23		200.00	975,950.52
05/15/2023	1180	Robert Renn	BOS Workshop 5/10/23		200.00	975,750.52
05/15/2023	1181	Shelia Papelbon	BOS Workshop 5/10/23		200.00	975,550.52
05/16/2023			Deposit	361.00		975,911.52
05/16/2023	0516ACH1	JEA	Service for the month of April		25,925.31	949,986.21
05/18/2023	0518ACH1	Comcast	12788 Meritace Blvd MINI MDTA 4/28/22 - 5/27/23		548.20	949,438.01
05/19/2023	100210	LLS Tax Solutions, Inc.	Invoice: 003010 (Reference: Arbitrage Services.) Invoice: 003011 (Reference: Arbitrage Servic..		5,850.00	943,588.01
05/19/2023	0519ACH1	TECO	12545 Beach Blvd - 3/23/23 - 4/21/23		36.91	943,551.10
05/22/2023	1182	Chance Wedderburn	BOS Meeting 5/15/23		200.00	943,351.10
05/22/2023	1183	Matthew Calderaro	BOS Meeting 5/15/23		200.00	943,151.10
05/22/2023	1184	Robert Renn	BOS Meeting 5/15/23		200.00	942,951.10
05/22/2023	1185	Shelia Papelbon	BOS Meeting 5/15/23		200.00	942,751.10
05/22/2023	0522ACH1	Comcast	12750 Meritage Blvd. GATEHOUSE 4/30/23 - 5/29/23		216.11	942,534.99
05/23/2023	0523ACH1	Florida Natural Gas	Fuel and Inside FGT Z3 3/22/23 - 4/23/23		10.47	942,524.52
05/23/2023	ACH 052323	Credit Card transactions			2,865.90	939,658.62
05/24/2023	100211	Magnetix DJ Services	Invoice: 3514 (Reference: Trivia Night.)		350.00	939,308.62
05/25/2023	100212	10-S Tennis Supply & Dinkshot Pickleball	Invoice: 159439 (Reference: Tennis Net & Scarifler.)		347.45	938,961.17
05/25/2023	100213	Advanced Security Specialist & Consulting	Invoice: T0052023A (Reference: 05.01.23 TO 05.15.23 GUARD HOUSE GATE ACCESS MAN.		9,000.00	929,961.17
05/25/2023	100214	Integrated Access Solutions	Invoice: 0003115 (Reference: BAI Barcodes Black on Black.) Invoice: 0003117 (Reference: Cor		782.78	929,178.39
05/25/2023	100215	Vesta District Services	Invoice: 410165 (Reference: Additional Workshop Hours.) Invoice: 410183 (Reference: District		4,923.25	924,255.14
05/25/2023	100216	Lucas Tree Service, Inc.	Invoice: 8407 (Reference: Drop dead pine tree.)		500.00	923,755.14
05/25/2023	0525ACH1	Comcast	12788 Meritage Blvd. OFC 4 5/3/23 - 6/2/23		361.24	923,393.90
05/26/2023			Deposit	19,081.04		942,474.94

05/30/2023	0530ACH1	Comcast	13077 Beach Blvd. PEDESTRIAN GATE May 10, 2023 - June 09, 2023	199.35	942,275.59
05/31/2023	100217	Jacksonville Daily Record	Invoice: 052523- (Reference: Legal Advertising.)	96.50	942,179.09
05/31/2023	100218	Southeastern Paper Group	Invoice: 05909762 (Reference: Janitorial Supplies.)	375.12	941,803.97
05/31/2023	100219	TEKWave Solutions LLC	Invoice: 5753 (Reference: VMS - JUNE.)	295.00	941,508.97
05/31/2023			Service Charge	2.60	941,506.37
05/31/2023	EOM Balance			38,529.34	98,570.93
06/01/2023	100220	First Coast Fun and Games	Invoice: 5430 (Reference: Lazer Tag.)	600.00	940,906.37
06/06/2023	100221	Integrated Access Solutions	Invoice: 0003176 (Reference: BAI Barcodes Black on Black.)	383.78	940,522.59
06/06/2023	100222	Kutak Rock LLP	Invoice: 3226004 (Reference: General Counsel.)	2,574.00	937,948.59
06/06/2023	100223	TEKWave Solutions LLC	Invoice: 5750 (Reference: Remote Device Set Up.)	200.00	937,748.59
06/06/2023	100224	Lucas Tree Service, Inc.	Invoice: 8470 (Reference: Drop 4 dead trees.)	1,000.00	936,748.59
06/07/2023			Deposit	3,754.82	940,503.41
06/08/2023	100225	The Lake Doctors, Inc.	Invoice: 720157 (Reference: Water Management - Zone 1,Water Management - Zone 2.)	1,767.00	938,736.41
06/08/2023	100226	VGlobal Tech	Invoice: 5102 (Reference: Monthly email hosting.)	50.00	938,686.41
06/08/2023	0608ACH1	GFL Environmental	Trash Service	195.31	938,491.10
06/12/2023	100227	Jacksonville Daily Record	Invoice: 060823- (Reference: Legal Advertising.)	96.50	938,394.60
06/12/2023	100228	Turner Pest Control	Invoice: 617256835 (Reference: Pest Control.)	115.21	938,279.39
06/12/2023	100229	Vesta Property Services	Invoice: 410821 (Reference: Billable Expenses.)	2,093.40	936,185.99
06/12/2023	100230	B.A.B Tennis Courts	Invoice: 2 (Reference: Final Draw Tennis Center Resurfacing Project.)	5,950.00	930,235.99
06/13/2023	0613ACH1	JEA	Service for the month of May	27,905.24	902,330.75
06/14/2023			Deposit	192.36	902,523.11
06/15/2023	1186	Turner Pest Control	Pest Control	115.21	902,407.90
06/15/2023	100231	Sun State Nursery & Landscaping, Inc	Invoice: 10176 (Reference: May Landscape Maintenance.)	35,213.10	867,194.80
06/15/2023	100232	Vesta Property Services	Invoice: 410762 (Reference: Amenity Management.)	23,020.64	844,174.16
06/15/2023	100233	Vesta District Services	Invoice: 410771 (Reference: Billable Expenses - May 2023.)	149.50	844,024.66
06/15/2023			Deposit	10,319.55	854,344.21
06/20/2023	100234	Advanced Security Specialist & Consulting	Invoice: T0062023A (Reference: 06.01.23 TO 06.15.23.)	9,000.00	845,344.21
06/20/2023	100235	TEKWave Solutions LLC	Invoice: 5776 (Reference: Vehicle Passes.)	935.00	844,409.21
06/20/2023	100236	Poker Face Comedy, LLC	Invoice: 000014 (Reference: Comedian for Father's Day Brunch.)	650.00	843,759.21
06/20/2023	0620ACH1	Comcast	12750 Meritage Blvd. GATEHOUSE 5/30/23 - 6/29/23	216.11	843,543.10
06/20/2023	0620ACH2	Comcast	12788 Meritace Blvd MINI MDTA 5/28/23 - 6/27/23	546.50	842,996.60
06/20/2023	0620ACH3	TECO	12545 Beach Blvd - 4/22/23 - 5/23/23	36.91	842,959.69
06/22/2023	01ACH062223	Florida Natural Gas	Fuel and Inside FGT Z3 4/21/23-5/23/23	10.67	842,949.02
06/23/2023	100237	Advanced Security Specialist & Consulting	Invoice: T0052023B (Reference: 05.16.23 TO 05.31.23.) Invoice: T0052023 (Reference: 5/1/23	12,682.50	830,266.52
06/23/2023	100238	Southeastern Paper Group	Invoice: 05928476 (Reference: Janitorial Supplies.)	359.87	829,906.65
06/23/2023	100239	Wayne Automatic Fire Sprinklers Inc.	Invoice: 1054267 (Reference: Quarterly Sprinkler Inspection.)	75.00	829,831.65
06/23/2023	100240	Vesta District Services	Invoice: 410895 (Reference: District Management Services.)	3,958.33	825,873.32
06/23/2023	100241	Wild Wonders	Invoice: 052423- (Reference: Scaly Sensations.)	300.00	825,573.32
06/23/2023	ACH 062323	Credit Card transactions		2,005.18	823,568.14
06/26/2023	0626ACH1	Comcast	12788 Meritage Blvd. OFC 4 6/3/23 - 7/2/23	359.30	823,208.84
06/28/2023	1189	Duval's Cleanest LLC	Pressure Washing Pillars & Entrance Sign	500.00	822,708.84
06/28/2023	1190	Magnetix DJ Services	MC/DJ Member Independence Pool Party	400.00	822,308.84
06/28/2023	1191	Screening One	Screening of Trainers	180.00	822,128.84
06/28/2023	1192	Tampa Print Services, Inc.	Printing Services	539.16	821,589.68
06/29/2023			Deposit	6,561.00	828,150.68
06/30/2023	0630ACH1	Comcast	13077 Beach Blvd. PEDESTRIAN GATE June 10, 2023 - July 9, 2023	199.35	827,951.33
06/30/2023			Service Charge	1.90	827,949.43
06/30/2023	EOM Balance			20,827.73	134,384.67
					827,949.43

EXHIBIT 8

Beach
Community Development District

Financial Statements
(Unaudited)

Preliminary

July 31, 2023

Beach CDD
Balance Sheet
July 31, 2023

	<u>General Fund</u>	<u>Debt Service 2013A</u>	<u>Debt Service 2015A</u>	<u>Construction</u>	<u>Total</u>
1 ASSETS					
2 OPERATING ACCOUNT BU	\$ 532,599	\$ -	\$ -	\$ -	\$ 532,599
3 PAYPAL ACCOUNT BU	-	-	-	-	-
4 CHECKING ACCOUNT CS	45,167	-	-	-	45,167
5 DEBT CARD ACCOUNT CS	893	-	-	-	893
6 DEBT SERVICE ACCOUNTS:					
7 SINKING FUND	-	-	-	-	-
8 INTEREST FUND	-	-	-	-	-
9 REDEMPTION FUND	-	37	150	-	187
10 PREPAYMENT FUND	-	48,832	25,435	-	74,268
11 REVENUE FUND	-	440,162	127,373	-	567,535
12 OP REDEMPTION FUND	-	-	-	-	-
13 ACQ & CONS 2013A	-	-	-	-	-
14 ACQ & CONS 2015A	-	-	-	-	-
15 ACCOUNTS RECEIVABLE	-	-	-	-	-
16 ASSESSMENTS RECEIVABLE ON-ROLL					
17 ASSESSMENTS RECEIVABLE OFF-ROLL	54,231	-	92,938	-	147,169
18 DUE FROM OTHER FUNDS	-	4,376	2,011	-	6,387
19 PREPAID	3,966	-	-	-	3,966
20 TOTAL ASSETS	\$ 636,856	\$ 493,407	\$ 247,907	\$ -	\$ 1,378,170
21 LIABILITIES					
22 ACCOUNTS PAYABLE	\$ 84,500	\$ -	\$ -	\$ -	\$ 84,500
23 DEFERRED REVENUE ON-ROLL	-	-	-	-	-
24 DEFERRED REVENUE OFF-ROLL	54,231	-	92,938	-	147,169
25 DUE TO OTHER FUNDS	6,387	-	-	-	6,387
26 OUTSTANDING CHECKS	-	-	-	-	-
27 TOTAL LIABILITIES	145,117	-	92,938	-	238,056
28 FUND BALANCE					
29 NONSPENDABLE					
30 PREPAID & DEPOSITS	3,966	-	-	-	3,966
31 CAPITAL RESERVES	109,319	-	-	-	109,319
32 OPERATING CAPITAL	-	-	-	-	-
33 UNASSIGNED	378,453	493,407	154,969	-	1,026,829
34 TOTAL FUND BALANCE	491,739	493,407	154,969	-	1,140,115
35 TOTAL LIABILITIES & FUND BALANCE	\$ 636,856	\$ 493,407	\$ 247,907	\$ -	\$ 1,378,170

Beach CDD
General Fund
Statement of Revenue, Expenditures, and Changes in Fund Balance
For the period from October 1, 2022 to July 31, 2023

	FY 2023 Adopted Budget	FY 2023 Month of July	FY 2023 Total Actual Year-to-Date	VARIANCE Over (Under) to Budget	% Actual YTD / FY Budget
1 REVENUE					
2 ASSESSMENTS ON-ROLL	\$ 1,402,321	\$ -	\$ 1,408,715	\$ 6,395	100%
3 ASSESSMENTS OFF-ROLL	216,924	-	162,693	(54,231)	75%
4 INTEREST REVENUE	-	3	23	23	
5 OTHER FINANCING SOURCES	5,000	15,857	35,597	30,597	712%
6 CARRYFORWARD	-	-	-	-	
7 TOTAL REVENUE	\$ 1,624,245	\$ 15,860	\$ 1,607,028	\$ (17,217)	99%
8 EXPENDITURES					
9 GENERAL & ADMINISTRATIVE EXPENSES					
10 TRUSTEE FEES	\$ 8,000	\$ -	\$ 8,200	\$ 200	103%
11 SUPERVISOR FEES-REGULAR MEETINGS	10,000	1,000	6,800	(3,200)	68%
12 SUPERVISOR FEES-WORKSHOPS	2,000	-	2,400	400	120%
13 DISTRICT MANAGEMENT	42,000	3,500	35,000	(7,000)	83%
14 ENGINEERING	2,500	-	2,157	(343)	86%
15 DISSEMINATION AGENT	2,500	-	2,500	-	100%
16 DISTRICT COUNSEL	7,500	-	19,976	12,476	266%
17 ASSESSMENT ADMINISTRATION	5,500	458	4,583	(917)	83%
18 REAMORTIZATION SCHEDULE	-	-	-	-	
19 ARBITRAGE REBATE CALCULATION	-	-	5,850	5,850	
20 AUDIT	6,000	3,250	3,250	(2,750)	54%
21 WEBSITE	1,515	50	2,152	637	142%
22 LEGAL ADVERTISING	1,750	-	4,631	2,881	265%
23 DUES, LICENSES & FEES	175	-	175	-	100%
24 GENERAL LIABILITY INSURANCE	4,057	-	-	(4,057)	0%
25 PUBLIC OFFICIAL INSURANCE	2,895	-	-	(2,895)	0%
26 OFFICE MISCELLANEOUS	2,000	560	8,230	6,230	412%
27 TOTAL GENERAL & ADMINISTRATIVE EXPENSES	98,392	8,819	105,904	7,512	108%
28 FIELD EXPENSES					
29 FIELD MANAGEMENT	133,553	9,307	96,787	(36,766)	72%
30 PROPERTY INSURANCE	89,054	-	88,097	(957)	99%
31 LAKE MAINTENANCE	21,600	1,767	16,926	(4,674)	78%
32 LANDSCAPING (INCLUDING MATERIALS)	402,792	-	291,392	(111,400)	72%
33 IRRIGATION (REPAIRS)	10,000	-	4,933	(5,067)	49%
34 ELECTRIC - STREET LIGHTS/IRRIGATION-JEA	188,475	23,870	208,036	19,561	110%
35 RIGHT OF WAY / LAKE MOWING	2,500	-	-	(2,500)	0%
36 ENTRY WATER FEATURE	7,500	-	-	(7,500)	0%
37 CARRYFORWARD REPLENISH	-	-	-	-	
38 CONTINGENCY - HURRICANE / STORM CLEAN UP	8,000	-	-	(8,000)	0%
39 COMMUNITY MAINTENANCE	8,000	849	16,382	8,382	205%
40 CAPITAL IMPROVEMENTS	39,080	-	3,575	(35,505)	9%
41 TOTAL FIELD EXPENSES	910,554	35,792	726,128	(184,426)	80%

42	AMENITY EXPENSES					
43	AMENITY MANAGEMENT	154,556	12,428	100,500	(54,056)	65%
44	BREEZEWAY STAFF	-	-	1,035	1,035	
45	LIFEGUARD	-	15,655	25,800	25,800	
46	SWIMMING POOL CHEMICALS	-	1,869	14,909	14,909	
47	SWIMMING POOL INSPECTION	-	-	851	851	
48	AMENITY GENERAL MAINTENANCE & REPAIRS	21,510	1,547	12,595	(8,915)	59%
49	AMENITY CLEANING	-	2,741	14,563	14,563	
50	AMENITY ELECTRIC/WATER AND SEWER	60,000	4,196	41,427	(18,573)	69%
51	AMENITY GATES/CONTROL ACCESS	5,000	427	12,170	7,170	243%
52	AMENITY WEBSITE/COMPUTER EQUIPMENT	1,590	137	2,233	643	140%
53	AMENITY INTERNET/CABLE	10,000	1,120	11,304	1,304	113%
54	AMENITY DUES & LICENSES	850	-	459	(391)	54%
55	AMENITY SECURITY	800	2,450	10,933	10,133	1367%
56	FITNESS EQUIPMENT MAINTENANCE	10,000	180	1,617	(8,383)	16%
57	LIFESTYLES PROGRAMMING	25,000	2,134	22,376	(2,624)	90%
58	AMENITY GAS	600	47	560	(40)	93%
59	TENNIS COURT MAINTENANCE - 4 CLAY COURTS	14,500	-	13,187	(1,313)	91%
60	LANDSCAPING MAINTENANCE AMENITY CENTER	68,400	-	25,333	(43,067)	37%
61	LANDSCAPE IMPROVEMENT	2,500	-	-	(2,500)	0%
62	AMENITY IRRIGATION (REPAIRS)	1,500	-	-	(1,500)	0%
63	PEST CONTROL	1,200	115	1,121	(79)	93%
64	AMENITY FIRE SYSTEM MONITORING	1,500	-	1,481	(19)	99%
65	ALARM	500	-	-	(500)	0%
66	TRASH COLLECTION	2,292	178	1,816	(477)	79%
67	TOTAL AMENITY EXPENSES	382,298	45,222	316,270	(66,028)	83%
68	ACCESS CONTROL /GATE HOUSE					
69	GUARD SERVICE	222,400	18,600	197,070	(25,330)	89%
70	GUARD HOUSE SUPPLIES	800	-	551	(249)	69%
71	GUARD HOUSE UTILITIES	3,800	349	2,579	(1,222)	68%
72	GUARD HOUSE REPAIR & MAINTENANCE	1,000	-	2,233	1,233	223%
73	BAR CODE EXPENSE	5,000	384	2,847	(2,153)	57%
74	TOTAL ACCESS CONTROL/GATE HOUSE EXPENSES	233,000	19,333	205,280	(27,720)	88%
75	TOTAL EXPENDITURES	1,624,245	109,166	1,353,582	(270,663)	83%
76	EXCESS OF REVENUE OVER (UNDER) EXPENDITURES	-	(93,306)	253,446	253,446	
77	OTHER FINANCING SOURCES & USES					
78	TRANSFER IN	-	-	-	-	
79	TRANSFER OUT	-	-	-	-	
80	TOTAL OTHER FINANCING SOURCES & USES	-	-	-	-	
81	FUND BALANCE - BEGINNING	239,612		238,292	(1,320)	
82	NET CHANGE IN FUND BALANCE	-	(93,306)	253,446	253,446	
83	FUND BALANCE - ENDING	\$ 239,612		\$ 491,739	\$ 252,126	
84	ANALYSIS OF FUND BALANCE					
85	NONSPENDABLE					
86	PREPAID & DEPOSITS	3,966		3,966		
87	CAPITAL RESERVES	109,319		109,319		
88	OPERATING CAPITAL	-		-		
89	UNASSIGNED	126,327		378,453		
90	TOTAL FUND BALANCE	\$ 239,612		\$ 491,739		

Beach CDD
Debt Service 2013A
Statement of Revenue, Expenditures, and Changes in Fund Balance
For the period from October 1, 2022 to July 31, 2023

	FY 2023 Adopted Budget	FY 2023 Actual Year-to-Date	VARIANCE Over (Under) to Budget
1 REVENUE			
2 ASSESSMENTS ON-ROLL	\$ 800,640	\$ 801,848	\$ 1,208
3 INTEREST REVENUE	-	7,282	7,282
4 MISC. REVENUE	-	63,504	63,504
5 TOTAL REVENUE	800,640	872,634	71,994
6 EXPENDITURES			
7 INTEREST EXPENSE			
8 November 1, 2022	-	313,908	313,908
9 May 1, 2023	313,920	311,425	(2,495)
10 November 1, 2023	308,058	-	(308,058)
11 PRINCIPAL RETIREMENT			
12 May 1, 2023	175,000	175,000	-
PRINCIPAL PREPAYMENT	-	85,000	85,000
13 TOTAL EXPENDITURES	796,978	885,333	(88,355)
14 EXCESS OF REVENUE OVER (UNDER) EXPENDITURES	3,663	(12,699)	(16,361)
15 OTHER FINANCING SOURCES (USES)			
16 TRANSFER IN	-	37	37
17 TRANSFER OUT (USES)	-	-	-
18 TOTAL OTHER FINANCING SOURCES (USES)	-	37	37
19 FUND BALANCE - BEGINNING	496,223	506,069	9,846
20 NET CHANGE IN FUND BALANCE	3,663	(12,661)	(16,324)
21 FUND BALANCE - ENDING	\$ 499,886	\$ 493,407	\$ (6,478)

Beach CDD
Debt Service 2015A
Statement of Revenue, Expenditures, and Changes in Fund Balance
For the period from October 1, 2022 to July 31, 2023

	FY 2023 Adopted Budget	FY 2023 Actual Year-to-Date	VARIANCE Over (Under) to Budget
1 REVENUE			
2 ASSESSMENTS ON-ROLL	\$ 366,911	\$ 368,556	\$ 1,646
3 ASSESSMENTS OFF-ROLL	232,345	139,257	(93,087)
4 INTEREST REVENUE	-	813	813
5 MISC. REVENUE	-	22,196	22,196
6 TOTAL REVENUE	599,255	530,822	(68,433)
7 EXPENDITURES			
8 INTEREST EXPENSE			
9 November 1, 2022	-	221,988	221,988
10 May 1, 2023	221,988	221,988	-
11 November 1, 2023	217,268	-	(217,268)
12 PRINCIPAL RETIREMENT			
13 May 1, 2023	160,000	165,000	5,000
14 TOTAL EXPENDITURES	599,255	608,975	(9,720)
15 EXCESS OF REVENUE OVER (UNDER) EXPENDITURES	-	(78,153)	(78,153)
16 OTHER FINANCING SOURCES (USES)			
17 TRANSFER IN	-	149	149
18 TRANSFER OUT (USES)	-	-	-
19 TOTAL OTHER FINANCING SOURCES (USES)	-	149	149
20 FUND BALANCE - BEGINNING	96,818	232,972	136,154
21 NET CHANGE IN FUND BALANCE	-	(78,003)	(78,003)
22 FUND BALANCE - ENDING	\$ 96,818	\$ 154,969	\$ 58,151

Beach CDD Check Register - FY2023

Date	Ref. Num	Name	Memo	Deposits	Disbursements	Balance
09/30/2022		EOY Balance				295,536.89
10/01/2022	1114	Egis Insurance and Risk Advisors	FY Insurance Policy # 100122192 10/01/22-10/01/23		88,097.00	207,439.89
10/11/2022	1118	Kristin A. Robinson, MD	Refund of Deposit for rental of Pool Cabana		50.00	207,389.89
10/11/2022	100036	Advanced Security Specialist & Consulting	Invoice: T0092022A (Reference: Guard House Gate Access Management.)		8,370.00	199,019.89
10/11/2022	100037	Air Solutions Heating & Cooling Inc	Invoice: 0000094932 (Reference: Installed a new condenser fan motor, fan blade, and capacitor.)		2,038.39	196,981.50
10/11/2022	100038	Integrated Access Solutions	Invoice: 0001453 (Reference: Installation of Indoor Access Point.) Invoice: 0001472 (Referenc..		459.89	196,521.61
10/11/2022	100039	Life Fitness	Invoice: 7173030 (Reference: Clutch Kit.)		62.45	196,459.16
10/11/2022	100040	Southeast Fitness	Invoice: 100493 (Reference: Semi-annually scheduled preventative maintenance.)		640.00	195,819.16
10/11/2022	100041	Southeastern Paper Group	Invoice: 05717495 (Reference: Supplies.)		423.90	195,395.26
10/11/2022	100042	Staples	Invoice: 8067623768 (Reference: Office Supplies.)		48.07	195,347.19
10/11/2022	100043	Sun State Nursery & Landscaping, Inc	Invoice: 7821 (Reference: Irrigation Repairs.) Invoice: 7911 (Reference: Installation of Clock...		2,236.49	193,110.70
10/11/2022	100044	Wayne Automatic Fire Sprinklers Inc.	Invoice: 952684 (Reference: Annual Extinguisher Certification Inspection.)		352.61	192,758.09
10/14/2022	100045	10-S Tennis Supply & Dinkshot Pickleball	Invoice: 156365 (Reference: Aluminum Drag Broom.) Invoice: 156337 (Reference: 10-S Linesr		437.61	192,320.48
10/14/2022	100046	Advanced Security Specialist & Consulting	Invoice: T0092022B (Reference: Guard House Gate Access Management.) Invoice: TA0092022		12,570.00	179,750.48
10/14/2022	100047	Innersync	Invoice: 20817 (Reference: Website Services.)		1,515.00	178,235.48
10/14/2022	100048	Sun State Nursery & Landscaping, Inc	Invoice: 7986 (Reference: October Landscape Maintenance.)		35,213.10	143,022.38
10/14/2022	100050	The Lake Doctors, Inc.	Invoice: 36532B (Reference: Water Management Zone 1 & 2.)		1,395.00	141,627.38
10/14/2022	100051	Turner Pest Control	Invoice: 19160304 (Reference: Monthly pest control.)		104.74	141,522.64
10/14/2022	100052	Vesta Property Services	Invoice: 403326 (Reference: September Fees.)		19,605.00	121,917.64
10/14/2022	100053	VGlobal Tech	Invoice: 4366 (Reference: Email hosting.)		50.00	121,867.64
10/14/2022	101422ACH1	JEA	Service for the month of September		27,918.90	93,948.74
10/15/2022	101522ACH1	Comcast	12788 Meritace Blvd MINI MDTA 9/28/22 to 10/27/22		535.58	93,413.16
10/17/2022	1119	Dominik Guess	Refund for Rental Cancellation		200.00	93,213.16
10/17/2022	1120	Instant PhotoCube	80's Casino Night		475.00	92,738.16
10/17/2022	101722ACH1	Comcast	12750 Meritage Blvd. GATEHOUSE 9/30-10/29/22		212.20	92,525.96
10/18/2022	101822ACH1	TECO	12545 Beach Blvd - 8/19/22 - 9/20/22		37.07	92,488.89
10/20/2022			Deposit	1,749.54		94,238.43
10/21/2022	102122ACH1	Florida Natural Gas	Fuel and Inside FGT Z3 8/19/22 - 9/18/22		17.79	94,220.64
10/22/2022	102222ACH1	Comcast	12788 Meritage Blvd. OFC 4 10/3-11/2/22		351.09	93,869.55
10/23/2022	ACH 102322	Credit Card transactions			693.49	93,176.06
10/24/2022	100054	Advanced Security Specialist & Consulting	Invoice: T0102022A (Reference: Guard House Gate Access Management.)		8,100.00	85,076.06
10/24/2022	100055	Integrated Access Solutions	Invoice: 0001945 (Reference: Service call.) Invoice: 0001950 (Reference: Service Call.) In...		900.00	84,176.06
10/24/2022	100056	Life Fitness	Invoice: 7195361 (Reference: Seat Pad.)		117.75	84,058.31
10/24/2022	100057	Southeastern Paper Group	Invoice: 05660098 (Reference: Paper Supplies.)		355.77	83,702.54
10/24/2022	100058	Staples	Invoice: 8067869974 (Reference: Office Supplies.)		400.17	83,302.37
10/26/2022	100059	Integrated Access Solutions	Invoice: 0001465 (Reference: Labor for installation, setup and testing.)		360.00	82,942.37
10/27/2022	102722ACH1	Comcast	13077 Beach Blvd. PEDESTRIAN GATE 10/10 -11/9/22		194.35	82,748.02
10/31/2022			Service Charge		1.45	82,746.57
10/31/2022		EOM Balance		1,749.54	214,539.86	82,746.57
11/03/2022			Deposit	3,000.00		85,746.57
11/07/2022	100060	DPFG M&C	Invoice: 403568 (Reference: Dissemination Agent.) Invoice: 403505 (Reference: District Manag		6,458.33	79,288.24
11/07/2022	100061	Advanced Security Specialist & Consulting	Invoice: TA0102022 (Reference: Amenities security.) Invoice: T0102022B (Reference: Guard H		11,070.00	68,218.24
11/07/2022	100062	Big Z Pool Service, LLC	Invoice: 11382 (Reference: Comp Pool, VFD Drive.)		1,970.00	66,248.24
11/07/2022	100063	Custom Pump & Controls, Inc.	Invoice: 22-314-04 (Reference: QUARTERLY LIFT STATION INSPECTION.)		150.00	66,098.24
11/07/2022	100064	GFL Environmental	Invoice: UG0000080959 (Reference: Nov 01/22 - Nov 30/22.)		162.01	65,936.23
11/07/2022	100065	Integrated Access Solutions	Invoice: 0002027 (Reference: BAI Barcodes Black on Black.) Invoice: 0002035 (Reference: ped		1,740.01	64,196.22
11/07/2022	100066	Kutak Rock LLP	Invoice: 3126899 (Reference: General Counsel.)		1,320.00	62,876.22

11/07/2022	100067	Sun State Nursery & Landscaping, Inc	Invoice: 8275 (Reference: Irrigation Repairs.) Invoice: 8273 (Reference: Irrigation Repairs. ...		779.17	62,097.05
11/07/2022	100068	TEKWave Solutions LLC	Invoice: 102622- (Reference: VMS - November 2022.)		295.00	61,802.05
11/07/2022	100069	Turner Pest Control	Invoice: 19363970 (Reference: Commercial Pest Control.)		104.74	61,697.31
11/07/2022	100070	VGlobal Tech	Invoice: 4416 (Reference: Email hosting.)		50.00	61,647.31
11/07/2022	100071	Wayne Automatic Fire Sprinklers Inc.	Invoice: 998491 (Reference: Annual Sprinkler Inspection.)		309.38	61,337.93
11/14/2022	1121	Matthew Calderaro	BOS MTG 11/7/22		200.00	61,137.93
11/14/2022	1122	Robert Renn	BOS MTG 11/7/22		200.00	60,937.93
11/14/2022	1123	Shelia Papelbon	BOS MTG 11/7/22		200.00	60,737.93
11/14/2022	1124	Stefanos Kounoupas	BOS MTG 11/7/22		200.00	60,537.93
11/16/2022	111622ACH1	JEA	Service for the month of October		23,682.22	36,855.71
11/17/2022			Deposit	187,055.02		223,910.73
11/17/2022	111722ACH1	TECO	12545 Beach Blvd - 09/21/2022 to 10/20/2022		37.08	223,873.65
11/18/2022	111822ACH1	Comcast	12788 Meritace Blvd MINI MDTA 10/28/22 to 11/27/22		534.81	223,338.84
11/21/2022	ACH11/21/22	Florida Natural Gas	Fuel and Inside FGT Z3 9/20/22 -10/20/22		15.19	223,323.65
11/21/2022	1125	FLORIDA DEPT OF ECONOMIC OPPORTUNIT	FY 2022/2023 Special District Fee Invoice/Update Form		175.00	223,148.65
11/21/2022	100072	Integrated Access Solutions	Invoice: 0002123 (Reference: Emergency Service Call.)		180.00	222,968.65
11/21/2022	100073	Game Time Game Truck, LLC	Invoice: 3014 (Reference: 2 Hour Game Truck.)		504.00	222,464.65
11/21/2022	100074	DPFG M&C	Invoice: 404412 (Reference: District Management Services.)		3,958.33	218,506.32
11/21/2022	100075	Sun State Nursery & Landscaping, Inc	Invoice: 8366 (Reference: November Landscape Maintenance.) Invoice: 8274 (Reference: Irrigat		35,533.06	182,973.26
11/21/2022	100076	The Lake Doctors, Inc.	Invoice: 45252B (Reference: Water Management Zone 1 & 2.)		1,395.00	181,578.26
11/21/2022	112122ACH1	Comcast	12750 Meritage Blvd. GATEHOUSE10/30/22 to 11/29/22		211.88	181,366.38
11/22/2022			Deposit	54,231.04		235,597.42
11/23/2022			Deposit	192.36		235,789.78
11/23/2022	ACH 112322	Credit Card transactions			1,245.71	234,544.07
11/25/2022			Deposit	284,806.31		519,350.38
11/25/2022	112522ACH1	Comcast	12788 Meritage Blvd. OFC 4 11/3/22 - 12/2/22		351.09	518,999.29
11/30/2022	113022ACH1	Comcast	13077 Beach Blvd. PEDESTRIAN GATE 11/10/22 to 12/9/22		194.35	518,804.94
11/30/2022			Service Charge		1.70	518,803.24
11/30/2022	EOM Balance			529,284.73	93,228.06	518,803.24
12/02/2022	100077	Vesta Property Services	Invoice: 404248 (Reference: October Fees.)		20,846.14	497,957.10
12/05/2022			Deposit	1,346,682.83		1,844,639.93
12/06/2022			Deposit	1,950.00		1,846,589.93
12/06/2022			Deposit	215,761.07		2,062,351.00
12/12/2022	100078	10-S Tennis Supply & Dinkshot Pickleball	Invoice: 157124 (Reference: Pro-Screen Open Mesh.)		882.34	2,061,468.66
12/12/2022	100079	Advanced Security Specialist & Consulting	Invoice: T0112022A (Reference: Guard House Gate Access Management.)		9,300.00	2,052,168.66
12/12/2022	100080	Bob's Backflow & Plumbiong Services	Invoice: 87517 (Reference: Backflow Test.)		450.00	2,051,718.66
12/12/2022	100081	Integrated Access Solutions	Invoice: 0002199 (Reference: Wireless HDMI adapter.)		369.00	2,051,349.66
12/12/2022	100083	Kutak Rock LLP	Invoice: 113022-23-1 (Reference: General Counsel.)		4,558.50	2,046,791.16
12/12/2022	100084	Southeast Fitness	Invoice: 100363 (Reference: 9/6/2022 Diagnosis or Repair.)		150.00	2,046,641.16
12/12/2022	100085	Southeastern Paper Group	Invoice: 05773688 (Reference: ECO-AIR.)		53.32	2,046,587.84
12/12/2022	100086	Sun State Nursery & Landscaping, Inc	Invoice: 8551 (Reference: Fix Breaks on the back side of wall.) Invoice: 8550 (Reference: Irr...		36,036.41	2,010,551.43
12/12/2022	100087	TEKWave Solutions LLC	Invoice: 5414 (Reference: December 2022.)		295.00	2,010,256.43
12/12/2022	100088	The Lake Doctors, Inc.	Invoice: 670593 (Reference: Monthly Water Management Service.) Invoice: 57370b (Reference:		3,095.00	2,007,161.43
12/12/2022	100089	Turner Pest Control	Invoice: 19972952 (Reference: Pest Control.)		104.74	2,007,056.69
12/12/2022	100090	Vesta Property Services	Invoice: 405450 (Reference: November Fees.)		19,793.78	1,987,262.91
12/12/2022	100091	VGlobal Tech	Invoice: 4492 (Reference: Email hosting.)		50.00	1,987,212.91
12/12/2022	100092	The Perfect Pour	Invoice: 0000151A (Reference: Bar Service for Halloween Party 10/21/22.)		625.00	1,986,587.91
12/12/2022	100093	Daytona Beach News-Journal	Invoice: 0005017635 (Reference: Oct 1 - Oct 31, 2022.)		1,003.25	1,985,584.66
12/13/2022	1126	Matthew Calderaro	BOS MTG 12/5/22		200.00	1,985,384.66
12/13/2022	1127	Robert Renn	BOS MTG 12/5/22		200.00	1,985,184.66
12/13/2022	1128	Shelia Papelbon	BOS MTG 12/5/22		200.00	1,984,984.66
12/14/2022			Deposit	192.36		1,985,177.02

12/14/2022	121422ACH1	JEA	Service for the month of November		25,621.04	1,959,555.98
12/16/2022			Deposit	165,311.36		2,124,867.34
12/19/2022	121922ACH1	Comcast	12788 Meritace Blvd MINI MDTA 11/28/22 - 12/27/22		534.81	2,124,332.53
12/20/2022	122022ACH1	Comcast	12750 Meritage Blvd. GATEHOUSE11/30/22 to 12/29/22		211.88	2,124,120.65
12/20/2022	122022ACH2	TECO	12545 Beach Blvd - 10/20/2022 -11/28/22		37.70	2,124,082.95
12/22/2022	122222ACH1	Florida Natural Gas	Fuel and Inside FGT Z3 10/20/22 to 11/28/22		14.35	2,124,068.60
12/23/2022	100094	DPFG M&C	Invoice: 405570 (Reference: District Management Services.)		3,958.33	2,120,110.27
12/23/2022	100095	Advanced Security Specialist & Consulting	Invoice: TA0112022 (Reference: Amenities security.) Invoice: T0112022B (Reference: Guard H		11,460.00	2,108,650.27
12/23/2022	100096	Integrated Access Solutions	Invoice: 0002285 (Reference: Gate Repair.) Invoice: 0002291 (Reference: Guard House Gate Ac		3,192.16	2,105,458.11
12/23/2022	100097	Southeastern Paper Group	Invoice: 05765238 (Reference: Supplies.) Invoice: 05748187 (Reference: Supplies.)		824.54	2,104,633.57
12/23/2022	100098	Staples	Invoice: 8068566313 (Reference: Office Supplies.)		383.73	2,104,249.84
12/23/2022	100099	Vesta Property Services	Invoice: 403470 (Reference: Billable Expenses.)		3,170.38	2,101,079.46
12/23/2022	100100	Daytona Beach News-Journal	Invoice: 0005119397 (Reference: Advertising.)		1,324.92	2,099,754.54
12/23/2022	ACH 122322	Credit Card transactions			301.35	2,099,453.19
12/27/2022	1129	Matthew Calderaro	BOS MTG 12/19/22		200.00	2,099,253.19
12/27/2022	1130	Robert Renn	BOS MTG 12/19/22		200.00	2,099,053.19
12/27/2022	1131	Shelia Papelbon	BOS MTG 12/19/22		200.00	2,098,853.19
12/27/2022	1132	Stefanos Kounoupas	BOS MTG 12/19/22		200.00	2,098,653.19
12/27/2022	122722ACH1	Comcast	12788 Meritage Blvd. OFC 4 12/3/22 - 1/2/23		351.09	2,098,302.10
12/28/2022	1133	DPFG M&C	August Billable Expenses		30.63	2,098,271.47
12/30/2022			Deposit	308.38		2,098,579.85
12/30/2022	123022ACH1	Comcast	13077 Beach Blvd. PEDESTRIAN GATE 12/10/22 to 1/9/23		194.35	2,098,385.50
12/31/2022			Service Charge		1.75	2,098,383.75
12/31/2022	EOM Balance			1,730,206.00	150,625.49	2,098,383.75
01/03/2023	1135	Magnetix DJ Services	Reference: Emcee & DJ Polar Plunge. https://dpfg.payableslockbox.com/DocView/InvoiceViewer		400.00	2,097,983.75
01/03/2023	1136	Shannon Brooke Thomas	Reference: Halloween Paint and Sip Event. https://dpfg.payableslockbox.com/DocView/InvoiceVi		150.00	2,097,833.75
01/03/2023	1137	Art-Z-Faces, Inc.	Reference: Santa Appearance. <a "="" href="https://dpfg.payableslockbox.com/DocView/InvoiceViewer.aspx?i=">https://dpfg.payableslockbox.com/DocView/InvoiceViewer.aspx?i=		300.00	2,097,533.75
01/03/2023	100101	Advanced Security Specialist & Consulting	Invoice: T0122022A (Reference: Guard House Gate Access Management.)		9,000.00	2,088,533.75
01/03/2023	100102	Southeastern Paper Group	Invoice: 05783796 (Reference: Supplies.)		258.71	2,088,275.04
01/03/2023	100103	Vesta Property Services	Invoice: 404351 (Reference: Billable Expenses.)		2,894.83	2,085,380.21
01/03/2023	100104	Daytona Beach News-Journal	Invoice: 0005097697 (Reference: Advertising.)		14.83	2,085,365.38
01/04/2023			Deposit	875.00		2,086,240.38
01/05/2023	1140	BNY Mellon Tax Distributions	Tax Distributions 2013A		689,260.69	1,396,979.69
01/05/2023	1141	BNY Mellon Tax Distributions	Tax Distributions 2015A		316,807.18	1,080,172.51
01/06/2023			Deposit	79,101.86		1,159,274.37
01/09/2023			Deposit	54,231.04		1,213,505.41
01/09/2023	100105	Advanced Security Specialist & Consulting	Invoice: TA0122022 (Reference: Amenities security.) Invoice: T0122022B (Reference: Guard H		12,060.00	1,201,445.41
01/09/2023	100106	Bob's Backflow & Plumbiong Services	Invoice: 88072 (Reference: Backflow Test.)		227.49	1,201,217.92
01/09/2023	100107	Integrated Access Solutions	Invoice: 0002350 (Reference: Service Call.) Invoice: 0001921 (Reference: Comcast modem bad		272.00	1,200,945.92
01/09/2023	100108	Kutak Rock LLP	Invoice: 3158252 (Reference: General Counsel.)		1,092.50	1,199,853.42
01/09/2023	100109	Sun State Nursery & Landscaping, Inc	Invoice: 8943 (Reference: January Landscape Maintenance.)		35,213.10	1,164,640.32
01/09/2023	100110	TEKWave Solutions LLC	Invoice: 5467 (Reference: Community Visitor Management Software.)		295.00	1,164,345.32
01/09/2023	100111	The Lake Doctors, Inc.	Invoice: 63731B (Reference: Water Management.)		1,767.00	1,162,578.32
01/09/2023	100112	Turner Pest Control	Invoice: 20497453 (Reference: Commercial Pest Control.)		104.74	1,162,473.58
01/09/2023	100113	VGlobal Tech	Invoice: 4623 (Reference: Email hosting.)		50.00	1,162,423.58
01/09/2023	100114	Wayne Automatic Fire Sprinklers Inc.	Invoice: 1014988 (Reference: WayneNet Fire Alarm Monitoring.)		750.00	1,161,673.58
01/09/2023	100115	Oxi Fresh Carpet Cleaning	Invoice: 1050 (Reference: Tile and Grout & Carpet Cleaning.) Invoice: 1051 (Reference: Tile a.		2,355.25	1,159,318.33
01/09/2023	100116	Bouncers, Slides, and More Inc.	Invoice: 12152022.03 (Reference: Movie Night.) Invoice: 10082022.16 (Reference: Obstacle Cc		1,330.00	1,157,988.33
01/15/2023	11523ACH1	Comcast	12788 Meritace Blvd MINI MDTA 12/28/22 - 1/27/23		547.90	1,157,440.43
01/17/2023	11723ACH1	Comcast	12750 Meritage Blvd. GATEHOUSE12/30/22 to 1/29/23		215.97	1,157,224.46
01/17/2023	100117	DPFG M&C	Invoice: 404329 (Reference: October Billable Expenses.)		48.95	1,157,175.51
01/18/2023	11823ACH1	TECO	12545 Beach Blvd - 11/28/22 - 12/19/22		40.25	1,157,135.26

01/18/2023			Deposit	192.36		1,157,327.62
01/19/2023	11922ACH1	JEA	Service for the month of December		27,981.75	1,129,345.87
01/20/2023	100118	DPFG M&C	Invoice: 406418 (Reference: December Billable Expenses.) Invoice: 406478 (Reference: District		4,104.61	1,125,241.26
01/20/2023	100119	Integrated Access Solutions	Invoice: 0002427 (Reference: Labor for installation, setup and testing.)		899.63	1,124,341.63
01/20/2023	100121	Sun State Nursery & Landscaping, Inc	Invoice: 8548 (Reference: Irrigation Repairs made during Inspection.)		142.18	1,124,199.45
01/20/2023	100122	Coastal Maintenance M.E. LLC	Invoice: 4165 (Reference: Holiday Lights.)		5,578.00	1,118,621.45
01/22/2023	12223ACH1	Comcast	12788 Meritage Blvd. OFC 4 1/3/23 - 2/2/23		361.28	1,118,260.17
01/23/2023	ACH012323	Florida Natural Gas	Fuel and Inside FGT Z3 11/28/22 to 12/19/22		23.99	1,118,236.18
01/23/2023	1142	Chance Wedderburn	BOS MTG 1/16/23		200.00	1,118,036.18
01/23/2023	1143	Matthew Calderaro	BOS MTG 1/16/23		200.00	1,117,836.18
01/23/2023	1144	Robert Renn	BOS MTG 1/16/23		200.00	1,117,636.18
01/23/2023	1145	Shelia Papelbon	BOS MTG 1/16/23		200.00	1,117,436.18
01/23/2023	1151	Stefanos Kounoupas	BOS MTG 1/16/23		200.00	1,117,236.18
01/23/2023	ACH 012323	Credit Card transactions			908.87	1,116,327.31
01/24/2023	1152	Brian T. Shirley	Stand-Up Comedy Show for Valentine's Day Cocktail Party		400.00	1,115,927.31
01/24/2023	1153	Ebony Lunsford	Cocktail Service		500.00	1,115,427.31
01/24/2023			Deposit	127,429.74		1,242,857.05
01/25/2023	100123	Advanced Security Specialist & Consulting	Invoice: T0012023A (Reference: Guard House Gate Access Management.)		9,300.00	1,233,557.05
01/25/2023	100124	Custom Pump & Controls, Inc.	Invoice: 23-314-01 (Reference: QUARTERLY LIFT STATION INSPECTION.)		150.00	1,233,407.05
01/25/2023	100125	E.T.M.	Invoice: 0206237 (Reference: Engineering Services.)		1,073.25	1,232,333.80
01/25/2023	100126	GFL Environmental	Invoice: UG0000087355 (Reference: Trash Service.)		193.73	1,232,140.07
01/25/2023	100127	Southeastern Paper Group	Invoice: 05806313 (Reference: PURELL HAND SANITIZING.)		175.71	1,231,964.36
01/25/2023	100128	Sun State Nursery & Landscaping, Inc	Invoice: 9019 (Reference: Irrigation Repairs Made During Monthly Inspection.)		151.79	1,231,812.57
01/25/2023	100129	Vesta Property Services	Invoice: 406387 (Reference: Billable Expenses.)		2,193.93	1,229,618.64
01/25/2023	100130	Daytona Beach News-Journal	Invoice: 0005202822 (Reference: Advertising.)		578.28	1,229,040.36
01/27/2023	1154	BNY Mellon Payment/Trustee Fees	Trustee Fees 2013A: November 01, 2022 to October 31, 2023		4,100.00	1,224,940.36
01/27/2023	1155	BNY Mellon Payment/Trustee Fees	Trustee Fees 2015A: November 01, 2022 to October 31, 2023		4,100.00	1,220,840.36
01/27/2023			Deposit	1,975.00		1,222,815.36
01/30/2023	1156	Magnetix DJ Services	Reference: Emcee & DJ Member Music Bingo Night		350.00	1,222,465.36
01/30/2023	13023ACH1	Comcast	13077 Beach Blvd. PEDESTRIAN GATE Jan 10, 2023 to Feb 09, 2023		199.35	1,222,266.01
01/31/2023			Service Charge		2.55	1,222,263.46
01/31/2023		EOM Balance		263,805.00	1,139,925.29	1,222,263.46
02/09/2023			Deposit	192.36		1,222,455.82
02/09/2023	100131	Advanced Security Specialist & Consulting	Invoice: T0012023B (Reference: Guard House Gate Access Management.)		9,600.00	1,212,855.82
02/09/2023	100132	Kutak Rock LLP	Invoice: 3170780 (Reference: General Counsel.)		1,897.50	1,210,958.32
02/09/2023	100133	Southeastern Paper Group	Invoice: 05817499 (Reference: Paper Supplies.)		297.63	1,210,660.69
02/09/2023	100134	Sun State Nursery & Landscaping, Inc	Invoice: 9158 (Reference: Valve Replacement.) Invoice: 9159 (Reference: Repair of break.) ...		36,225.90	1,174,434.79
02/09/2023	100135	TEKWave Solutions LLC	Invoice: 5523 (Reference: Visitor Management Software-JAN.)		295.00	1,174,139.79
02/09/2023	100136	The Lake Doctors, Inc.	Invoice: 72574B (Reference: Water Management.)		1,767.00	1,172,372.79
02/09/2023	100137	Turner Pest Control	Invoice: 20597624 (Reference: Pest Control.)		115.21	1,172,257.58
02/09/2023	100138	VGlobal Tech	Invoice: 4735 (Reference: Email:Email hosting.)		50.00	1,172,207.58
02/09/2023	100139	Community Advisors, LLC	Invoice: 1537 (Reference: Reserve Analysis.)		4,900.00	1,167,307.58
02/13/2023	100140	GFL Environmental	Invoice: UG000090424 (Reference: Trash Service.)		177.88	1,167,129.70
02/15/2023	21523ACH1	JEA	Service for the month of January		20,109.16	1,147,020.54
02/17/2023			Deposit	9,913.18		1,156,933.72
02/21/2023	22123ACH1	Comcast	12788 Meritace Blvd MINI MDTA 1/28/22 - 2/27/23		548.46	1,156,385.26
02/21/2023	22123ACH2	Comcast	12750 Meritage Blvd. GATEHOUSE1/30/23 to 2/28/23		216.20	1,156,169.06
02/21/2023	22123ACH3	TECO	12545 Beach Blvd - 12/20/22 - 1/23/23		56.44	1,156,112.62
02/23/2023	100141	Integrated Access Solutions	Invoice: 0002621 (Reference: Service Call.)		264.00	1,155,848.62
02/23/2023	100142	Southeastern Paper Group	Invoice: 05802879 (Reference: Paper Supplies.)		386.21	1,155,462.41
02/23/2023	100143	Vesta Property Services	Invoice: 406329 (Reference: December Fees.) Invoice: 405487 (Reference: Billable Expenses.)		46,194.31	1,109,268.10
02/23/2023	22323ACH1	Florida Natural Gas	Fuel and Inside FGT Z3 12/19/22 - 1/23/23		42.56	1,109,225.54

02/23/2023	ACH 022323	Credit Card transactions		1,977.35	1,107,248.19
02/27/2023	100144	DPFG M&C	Invoice: 407496 (Reference: January Billable Expenses.) Invoice: 407582 (Reference: District ...	4,066.06	1,103,182.13
02/27/2023	100145	Advanced Security Specialist & Consulting	Invoice: T0022023A (Reference: Guard House Gate Access Management.) Invoice: TA0012023	10,980.00	1,092,202.13
02/27/2023	100146	Bob's Backflow & Plumbing Services	Invoice: 89479 (Reference: Backflow Test.)	225.00	1,091,977.13
02/27/2023	100147	GFL Environmental	Invoice: UG0000093668 (Reference: Trash Service.)	177.88	1,091,799.25
02/27/2023	100148	Integrated Access Solutions	Invoice: 0002655 (Reference: BAI Barcodes Black on Black.)	383.78	1,091,415.47
02/27/2023	100149	Sun State Nursery & Landscaping, Inc	Invoice: 9472 (Reference: Irrigation Repairs made during Inspection.)	493.19	1,090,922.28
02/27/2023	100150	Turner Pest Control	Invoice: 20704326 (Reference: Pest Control.)	115.21	1,090,807.07
02/27/2023	100151	Vesta Property Services	Invoice: 407489 (Reference: Billable Expenses.)	592.85	1,090,214.22
02/27/2023	1157	Chance Wedderburn	BOS MTG 2/20/23	200.00	1,090,014.22
02/27/2023	1158	Matthew Calderaro	BOS MTG 2/20/23	200.00	1,089,814.22
02/27/2023	1159	Robert Renn	BOS MTG 2/20/23	200.00	1,089,614.22
02/27/2023	1160	Shelia Papelbon	BOS MTG 2/20/23	200.00	1,089,414.22
02/27/2023	1161	Stefanos Kounoupas	BOS MTG 2/20/23	200.00	1,089,214.22
02/27/2023		Deposit		1,375.00	1,090,589.22
02/27/2023		Deposit		3,297.16	1,093,886.38
02/28/2023		Service Charge		1.40	1,093,884.98
02/28/2023	EOM Balance			14,777.70	143,156.18
03/01/2023	ACH030123	Bank United	Check 126 deposited 02/27 Chargeback Fee	35.00	1,093,849.98
03/02/2023	030223ACH1	Comcast	13077 Beach Blvd. PEDESTRIAN GATE 2/10/23 - 3/9/23	199.35	1,093,650.63
03/03/2023	1162	Live Entertainment Solutions, LLC	DJ for Trivia Night on 3/16/23 including supplies	275.00	1,093,375.63
03/06/2023		Deposit		6,849.03	1,100,224.66
03/08/2023		Deposit		192.36	1,100,417.02
03/09/2023	100152	Advanced Security Specialist & Consulting	Invoice: TA0022023 (Reference: Amenities security.) Invoice: T0022023B (Reference: Guard H	9,960.00	1,090,457.02
03/09/2023	100153	Kutak Rock LLP	Invoice: 3182997 (Reference: General Counsel.)	1,901.50	1,088,555.52
03/09/2023	100154	TEKWave Solutions LLC	Invoice: 5578 (Reference: Visitor Management Software.)	295.00	1,088,260.52
03/09/2023	100155	First Coast Mulch	Invoice: 4831 (Reference: Mulch Installation:Playground Chips.)	3,575.00	1,084,685.52
03/13/2023	100156	Southeastern Paper Group	Invoice: 05829171 (Reference: Supplies.)	376.43	1,084,309.09
03/13/2023	100157	Sun State Nursery & Landscaping, Inc	Invoice: 9616 (Reference: March Landscape Maintenance.)	35,213.10	1,049,095.99
03/13/2023	100158	The Lake Doctors, Inc.	Invoice: 76968B (Reference: Water Management.)	1,767.00	1,047,328.99
03/13/2023	100159	Vesta Property Services	Invoice: 408152 (Reference: Amenity Management.)	18,973.93	1,028,355.06
03/13/2023	100160	VGlobal Tech	Invoice: 4781 (Reference: Email hosting.)	50.00	1,028,305.06
03/13/2023	100161	Wayne Automatic Fire Sprinklers Inc.	Invoice: 1030521 (Reference: Annual Extinguisher Certification Inspection.) Invoice: 1030371 .	346.73	1,027,958.33
03/14/2023	1163	Matthew Calderaro	BOS MTG 3/09/23	200.00	1,027,758.33
03/14/2023	1164	Stefanos Kounoupas	BOS MTG 3/9/23	200.00	1,027,558.33
03/16/2023		Deposit		61,862.73	1,089,421.06
03/17/2023	31723ACH1	JEA	Service for the month of February	18,352.18	1,071,068.88
03/20/2023	ACH032023	TECO	12545 Beach Blvd - 1/24/23 - 2/21/23	41.09	1,071,027.79
03/20/2023	032023ACH1	Comcast	12750 Meritage Blvd. GATEHOUSE 3/01/23 to 3/29/23	216.20	1,070,811.59
03/20/2023	32023ACH2	Comcast	12788 Meritace Blvd MINI MDTA 2/28/22 - 3/27/23	548.42	1,070,263.17
03/23/2023	ACH032323	Florida Natural Gas	Fuel and Inside FGT Z3 1/23/23 - 2/21/23	16.08	1,070,247.09
03/23/2023	100162	DPFG M&C	Invoice: 408425 (Reference: District Management Services.) Invoice: 408367 (Reference: Billab	4,224.33	1,066,022.76
03/23/2023	100163	Advanced Security Specialist & Consulting	Invoice: T0032023A (Reference: Guard House Gate Access Management.)	9,000.00	1,057,022.76
03/23/2023	100165	Vesta Property Services	Invoice: 408342 (Reference: Billable Expenses.)	603.48	1,056,419.28
03/23/2023	ACH 032323	Credit Card transactions		2,530.22	1,053,889.06
03/27/2023	22723ACH1	Comcast	12788 Meritage Blvd. OFC 4 2/3/23 - 3/2/23	361.29	1,053,527.77
03/27/2023	1165	Chance Wedderburn	BOS MTG 3/20/23	200.00	1,053,327.77
03/27/2023	1166	Matthew Calderaro	BOS MTG 3/20/23	200.00	1,053,127.77
03/27/2023	1167	Robert Renn	BOS MTG 3/20/23	200.00	1,052,927.77
03/27/2023	1168	Shelia Papelbon	BOS MTG 3/20/23	200.00	1,052,727.77
03/27/2023	100166	GFL Environmental	Invoice: UG0000096764 (Reference: Trash Service.)	195.31	1,052,532.46
03/27/2023	100167	Integrated Access Solutions	Invoice: 0002826 (Reference: Installation, set-up & testing.)	1,383.00	1,051,149.46

03/27/2023	032723ACH1	Comcast	12788 Meritage Blvd. OFC 4 3/3/23 - 4/2/23		361.24	1,050,788.22
03/28/2023			Deposit	600.00		1,051,388.22
03/30/2023	030323ACH1	Comcast	13077 Beach Blvd. PEDESTRIAN GATE Mar 10, 2023 to Apr 09, 2023		199.35	1,051,188.87
03/31/2023	100168	Bob's Backflow & Plumbiong Services	Invoice: 90342 (Reference: replace the existing backflow preventer.)		1,597.00	1,049,591.87
03/31/2023	100169	Southeastern Paper Group	Invoice: 05856941 (Reference: Paper Supplisr.) Invoice: 05853072 (Reference: Paper Supplies.		423.65	1,049,168.22
03/31/2023	100170	Sun State Nursery & Landscaping, Inc	Invoice: 9802 (Reference: Irrigation Repairs.)		925.95	1,048,242.27
03/31/2023	100171	TEKWave Solutions LLC	Invoice: 5632 (Reference: VMS - APRIL.)		295.00	1,047,947.27
03/31/2023	100172	Turner Pest Control	Invoice: 617040310 ()		115.21	1,047,832.06
03/31/2023	100173	Beaches Electrical Service, Inc.	Invoice: 11802 (Reference: Service Call.)		187.50	1,047,644.56
03/31/2023			Service Charge		1.80	1,047,642.76
03/31/2023		EOM Balance		69,504.12	115,746.34	1,047,642.76
04/03/2023	1169	Weinglass Music	Musician 4/13/23		500.00	1,047,142.76
04/06/2023	100174	Advanced Security Specialist & Consulting	Invoice: TA0032023 (Reference: Amenities security.) Invoice: T0032023B (Reference: Guard H		12,330.00	1,034,812.76
04/06/2023	100175	Integrated Access Solutions	Invoice: 0002866 (Reference: Service call response to check Amenity NVR HDD.) Invoice: 000.		528.00	1,034,284.76
04/06/2023	100176	Life Fitness	Invoice: 7337480 (Reference: Parts.) Invoice: 7336389 (Reference: Parts.)		46.86	1,034,237.90
04/06/2023	100177	Southeast Fitness	Invoice: 101452 (Reference: Semi-annually scheduled preventative maintenance.)		640.00	1,033,597.90
04/06/2023	100178	Sun State Nursery & Landscaping, Inc	Invoice: 9947 (Reference: April Landscape Maintenance.)		35,213.10	998,384.80
04/06/2023	100179	The Lake Doctors, Inc.	Invoice: 84489B (Reference: Water Management.)		1,767.00	996,617.80
04/11/2023			Deposit	192.36		996,810.16
04/11/2023			Deposit	18,840.21		1,015,650.37
04/14/2023	100180	Custom Pump & Controls, Inc.	Invoice: 23-314-02 (Reference: QUARTERLY LIFT STATION INSPECTION.)		150.00	1,015,500.37
04/14/2023	100181	Integrated Access Solutions	Invoice: 0002934 (Reference: Main Control Board & Liftmaster Motor.)		1,308.91	1,014,191.46
04/14/2023	100182	Kutak Rock LLP	Invoice: 3197846 (Reference: Beach CDD - General Counsel.)		3,028.00	1,011,163.46
04/14/2023	100183	Southeastern Paper Group	Invoice: 05870004 (Reference: Supplies.)		568.49	1,010,594.97
04/14/2023	100184	Vesta Property Services	Invoice: 409165 (Reference: Amenity Management.) Invoice: 409239 (Reference: Billable Expe		21,301.36	989,293.61
04/14/2023	100185	VGloba Tech	Invoice: 4929 (Reference: Email hosting.)		50.00	989,243.61
04/14/2023	100186	JT's Home Solutions LLC	Invoice: 197 (Reference: Touch up painting - Fitness Room.)		750.00	988,493.61
04/17/2023	0417ACH1	JEA	Service for the month of March		21,430.34	967,063.27
04/18/2023	1170	The Perfect Pour	Event at Tamaya 4/13/23		450.00	966,613.27
04/18/2023	0418ACH1	Comcast	12788 Meritace Blvd MINI MDTA 3/28/22 - 4/27/23		548.42	966,064.85
04/19/2023	0419ACH1	TECO	12545 Beach Blvd - 2/22/23 - 3/22/23		36.35	966,028.50
04/19/2023			Deposit	3,451.56		969,480.06
04/20/2023			Deposit	54,231.04		1,023,711.10
04/20/2023	Wire042023	BNY Mellon Payment/Trustee Fees	Off Roll Assessment 2015A-1		139,418.70	884,292.40
04/20/2023	0420ACH1	Comcast	12750 Meritage Blvd. GATEHOUSE 3/30/23 - 4/29/23		216.20	884,076.20
04/20/2023			Deposit	139,406.70		1,023,482.90
04/21/2023	ACH042123	Florida Natural Gas	Fuel and Inside FGT Z3 2/23/23 - 3/22/23		10.23	1,023,472.67
04/24/2023	1171	Chance Wedderburn	BOS MTG 4/17/23		200.00	1,023,272.67
04/24/2023	1172	Matthew Calderaro	BOS MTG 4/17/23		200.00	1,023,072.67
04/24/2023	1173	Robert Renn	BOS MTG 4/17/23		200.00	1,022,872.67
04/24/2023	100187	Advanced Security Specialist & Consulting	Invoice: T0042023A (Reference: Guard House Gate Access Management.)		9,000.00	1,013,872.67
04/24/2023	100188	Big Z Pool Service, LLC	Invoice: 12240 (Reference: warranty sump pumps.)		392.00	1,013,480.67
04/24/2023	100189	Integrated Access Solutions	Invoice: 0002962 (Reference: Service Call Driveway resident entry barrier arm.) Invoice: 0002...		954.14	1,012,526.53
04/24/2023	100190	B.A.B Tennis Courts	Invoice: 1 (Reference: Tennis Center Resurfacing Project.)		5,950.00	1,006,576.53
04/24/2023	100191	Vesta District Services	Invoice: 409333 (Reference: District Management Services.)		3,958.33	1,002,618.20
04/24/2023	ACH 042423	Credit Card transactions			2,026.15	1,000,592.05
04/25/2023	0425ACH1	Comcast	12788 Meritage Blvd. OFC 4 4/3/23 - 5/2/23		361.24	1,000,230.81
04/27/2023			Deposit	1,320.00		1,001,550.81
04/30/2023			Service Charge		2.85	1,001,547.96
04/30/2023		EOM Balance		217,441.87	263,536.67	1,001,547.96
05/01/2023	1174	Chance Wedderburn	BOS Workshop 4/26/23		200.00	1,001,347.96
05/01/2023	1175	Matthew Calderaro	BOS Workshop 4/26/23		200.00	1,001,147.96

05/01/2023	1176	Robert Renn	BOS Workshop 4/26/23		200.00	1,000,947.96
05/01/2023	0501ACH1	Comcast	13077 Beach Blvd. PEDESTRIAN GATE Apr 09, 2023 to May 10, 2023		199.35	1,000,748.61
05/02/2023			Deposit	661.00		1,001,409.61
05/04/2023	100192	Magnetix DJ Services	Invoice: 3513 (Reference: Emcee & DJ Member Trivia Night.)		350.00	1,001,059.61
05/04/2023			Deposit	18,233.94		1,019,293.55
05/05/2023	100193	Advanced Security Specialist & Consulting	Invoice: T0042023B (Reference: Guard House Gate Access Management.) Invoice: TA0042023		11,520.00	1,007,773.55
05/05/2023	100194	Integrated Access Solutions	Invoice: 0003005 (Reference: Service Call.) Invoice: 0003024 (Reference: Service Call - Fitne...		411.00	1,007,362.55
05/05/2023	100195	Kutak Rock LLP	Invoice: 3211113 (Reference: General Counsel.)		1,938.00	1,005,424.55
05/05/2023	100196	TEKWave Solutions LLC	Invoice: 5684 (Reference: Visitor Management Software.)		295.00	1,005,129.55
05/05/2023	100197	The Lake Doctors, Inc.	Invoice: 91916B (Reference: Water Management.)		1,767.00	1,003,362.55
05/05/2023	100198	VGlobel Tech	Invoice: 5000 (Reference: Email hosting.)		50.00	1,003,312.55
05/05/2023	100199	SS Live Entertainment, LLC	Invoice: 2854 (Reference: Live Entertainment 4.22.23.)		500.00	1,002,812.55
05/05/2023	100200	Bouncers, Slides, and More Inc.	Invoice: 042423- (Reference: Bounce House & Obstacle Course.)		500.00	1,002,312.55
05/05/2023	100201	Beaches Electrical Service, Inc.	Invoice: 11957 (Reference: Service call on Fountain.)		125.00	1,002,187.55
05/05/2023	100202	Vesta District Services	Invoice: 409273 (Reference: Billable Expenses - March 2023.)		127.76	1,002,059.79
05/10/2023	01ACH051023	Florida Department of Health	Pool permit 16-60-1627485		325.35	1,001,734.44
05/10/2023	02ACH051023	Florida Department of Health	Pool permit 16-60-1627490		325.35	1,001,409.09
05/10/2023	03ACH051023	Florida Department of Health	Pool permit16-60-1679058		200.35	1,001,208.74
05/10/2023	0510ACH1	GFL Environmental	Trash Service		195.31	1,001,013.43
05/11/2023			Deposit	192.36		1,001,205.79
05/12/2023	1177	TEKWave Solutions LLC			1,180.00	1,000,025.79
05/12/2023	100203	Buehler Air Conditioning	Invoice: 106529 (Reference: Service Call.)		491.10	999,534.69
05/12/2023	100204	Jacksonville Daily Record	Invoice: 050423- (Reference: Advertising Supervisors Meeting.) Invoice: 041323- (Reference: .		282.76	999,251.93
05/12/2023	100205	Southeastern Paper Group	Invoice: 05895051 (Reference: Supplies.)		512.01	998,739.92
05/12/2023	100206	Sun State Nursery & Landscaping, Inc	Invoice: 10106 (Reference: Irrigation Repairs during Inspection.)		284.75	998,455.17
05/12/2023	100207	Vesta Property Services	Invoice: 410072 (Reference: Amenity Management.) Invoice: 410012 (Reference: Billable Expe		20,729.65	977,725.52
05/12/2023	100208	SS Live Entertainment, LLC	Invoice: 2860 (Reference: Live Entertainment 5/28 & 5/29/23.)		1,000.00	976,725.52
05/12/2023	100209	Trice Music Services, Inc.	Invoice: 00515 (Reference: Entertainment - May 27th.)		375.00	976,350.52
05/15/2023	1178	Chance Wedderburn	BOS Workshop 5/10/23		200.00	976,150.52
05/15/2023	1179	Matthew Calderaro	BOS Workshop 5/10/23		200.00	975,950.52
05/15/2023	1180	Robert Renn	BOS Workshop 5/10/23		200.00	975,750.52
05/15/2023	1181	Shelia Papelbon	BOS Workshop 5/10/23		200.00	975,550.52
05/16/2023			Deposit	361.00		975,911.52
05/16/2023	0516ACH1	JEA	Service for the month of April		25,925.31	949,986.21
05/18/2023	0518ACH1	Comcast	12788 Meritace Blvd MINI MDTA 4/28/22 - 5/27/23		548.20	949,438.01
05/19/2023	100210	LLS Tax Solutions, Inc.	Invoice: 003010 (Reference: Arbitrage Services.) Invoice: 003011 (Reference: Arbitrage Servic..		5,850.00	943,588.01
05/19/2023	0519ACH1	TECO	12545 Beach Blvd - 3/23/23 - 4/21/23		36.91	943,551.10
05/22/2023	1182	Chance Wedderburn	BOS Meeting 5/15/23		200.00	943,351.10
05/22/2023	1183	Matthew Calderaro	BOS Meeting 5/15/23		200.00	943,151.10
05/22/2023	1184	Robert Renn	BOS Meeting 5/15/23		200.00	942,951.10
05/22/2023	1185	Shelia Papelbon	BOS Meeting 5/15/23		200.00	942,751.10
05/22/2023	0522ACH1	Comcast	12750 Meritage Blvd. GATEHOUSE 4/30/23 - 5/29/23		216.11	942,534.99
05/23/2023	0523ACH1	Florida Natural Gas	Fuel and Inside FGT Z3 3/22/23 - 4/23/23		10.47	942,524.52
05/23/2023	ACH 052323	Credit Card transactions			2,865.90	939,658.62
05/24/2023	100211	Magnetix DJ Services	Invoice: 3514 (Reference: Trivia Night.)		350.00	939,308.62
05/25/2023	100212	10-S Tennis Supply & Dinkshot Pickleball	Invoice: 159439 (Reference: Tennis Net & Scarifler.)		347.45	938,961.17
05/25/2023	100213	Advanced Security Specialist & Consulting	Invoice: T0052023A (Reference: 05.01.23 TO 05.15.23 GUARD HOUSE GATE ACCESS MAN.		9,000.00	929,961.17
05/25/2023	100214	Integrated Access Solutions	Invoice: 0003115 (Reference: BAI Barcodes Black on Black.) Invoice: 0003117 (Reference: Cor		782.78	929,178.39
05/25/2023	100215	Vesta District Services	Invoice: 410165 (Reference: Additional Workshop Hours.) Invoice: 410183 (Reference: District		4,923.25	924,255.14
05/25/2023	100216	Lucas Tree Service, Inc.	Invoice: 8407 (Reference: Drop dead pine tree.)		500.00	923,755.14
05/25/2023	0525ACH1	Comcast	12788 Meritage Blvd. OFC 4 5/3/23 - 6/2/23		361.24	923,393.90
05/26/2023			Deposit	19,081.04		942,474.94

05/30/2023	0530ACH1	Comcast	13077 Beach Blvd. PEDESTRIAN GATE May 10, 2023 - June 09, 2023	199.35	942,275.59
05/31/2023	100217	Jacksonville Daily Record	Invoice: 052523- (Reference: Legal Advertising.)	96.50	942,179.09
05/31/2023	100218	Southeastern Paper Group	Invoice: 05909762 (Reference: Janitorial Supplies.)	375.12	941,803.97
05/31/2023	100219	TEKWave Solutions LLC	Invoice: 5753 (Reference: VMS - JUNE.)	295.00	941,508.97
05/31/2023			Service Charge	2.60	941,506.37
05/31/2023		EOM Balance		38,529.34	98,570.93
06/01/2023	100220	First Coast Fun and Games	Invoice: 5430 (Reference: Lazer Tag.)	600.00	940,906.37
06/06/2023	100221	Integrated Access Solutions	Invoice: 0003176 (Reference: BAI Barcodes Black on Black.)	383.78	940,522.59
06/06/2023	100222	Kutak Rock LLP	Invoice: 3226004 (Reference: General Counsel.)	2,574.00	937,948.59
06/06/2023	100223	TEKWave Solutions LLC	Invoice: 5750 (Reference: Remote Device Set Up.)	200.00	937,748.59
06/06/2023	100224	Lucas Tree Service, Inc.	Invoice: 8470 (Reference: Drop 4 dead trees.)	1,000.00	936,748.59
06/07/2023			Deposit	3,754.82	940,503.41
06/08/2023	100225	The Lake Doctors, Inc.	Invoice: 720157 (Reference: Water Management - Zone 1,Water Management - Zone 2.)	1,767.00	938,736.41
06/08/2023	100226	VGlobal Tech	Invoice: 5102 (Reference: Monthly email hosting.)	50.00	938,686.41
06/08/2023	0608ACH1	GFL Environmental	Trash Service	195.31	938,491.10
06/12/2023	100227	Jacksonville Daily Record	Invoice: 060823- (Reference: Legal Advertising.)	96.50	938,394.60
06/12/2023	100228	Turner Pest Control	Invoice: 617256835 (Reference: Pest Control.)	115.21	938,279.39
06/12/2023	100229	Vesta Property Services	Invoice: 410821 (Reference: Billable Expenses.)	2,093.40	936,185.99
06/12/2023	100230	B.A.B Tennis Courts	Invoice: 2 (Reference: Final Draw Tennis Center Resurfacing Project.)	5,950.00	930,235.99
06/13/2023	0613ACH1	JEA	Service for the month of May	27,905.24	902,330.75
06/14/2023			Deposit	192.36	902,523.11
06/15/2023	1186	Turner Pest Control	Pest Control	115.21	902,407.90
06/15/2023	100231	Sun State Nursery & Landscaping, Inc	Invoice: 10176 (Reference: May Landscape Maintenance.)	35,213.10	867,194.80
06/15/2023	100232	Vesta Property Services	Invoice: 410762 (Reference: Amenity Management.)	23,020.64	844,174.16
06/15/2023	100233	Vesta District Services	Invoice: 410771 (Reference: Billable Expenses - May 2023.)	149.50	844,024.66
06/15/2023			Deposit	10,319.55	854,344.21
06/20/2023	100234	Advanced Security Specialist & Consulting	Invoice: T0062023A (Reference: 06.01.23 TO 06.15.23.)	9,000.00	845,344.21
06/20/2023	100235	TEKWave Solutions LLC	Invoice: 5776 (Reference: Vehicle Passes.)	935.00	844,409.21
06/20/2023	100236	Poker Face Comedy, LLC	Invoice: 000014 (Reference: Comedian for Father's Day Brunch.)	650.00	843,759.21
06/20/2023	0620ACH1	Comcast	12750 Meritage Blvd. GATEHOUSE 5/30/23 - 6/29/23	216.11	843,543.10
06/20/2023	0620ACH2	Comcast	12788 Meritace Blvd MINI MDTA 5/28/23 - 6/27/23	546.50	842,996.60
06/20/2023	0620ACH3	TECO	12545 Beach Blvd - 4/22/23 - 5/23/23	36.91	842,959.69
06/22/2023	01ACH062223	Florida Natural Gas	Fuel and Inside FGT Z3 4/21/23-5/23/23	10.67	842,949.02
06/23/2023	100237	Advanced Security Specialist & Consulting	Invoice: T0052023B (Reference: 05.16.23 TO 05.31.23.) Invoice: T0052023 (Reference: 5/1/23	12,682.50	830,266.52
06/23/2023	100238	Southeastern Paper Group	Invoice: 05928476 (Reference: Janitorial Supplies.)	359.87	829,906.65
06/23/2023	100239	Wayne Automatic Fire Sprinklers Inc.	Invoice: 1054267 (Reference: Quarterly Sprinkler Inspection.)	75.00	829,831.65
06/23/2023	100240	Vesta District Services	Invoice: 410895 (Reference: District Management Services.)	3,958.33	825,873.32
06/23/2023	100241	Wild Wonders	Invoice: 052423- (Reference: Scaly Sensations.)	300.00	825,573.32
06/23/2023	ACH 062323	Credit Card transactions		2,005.18	823,568.14
06/26/2023	0626ACH1	Comcast	12788 Meritage Blvd. OFC 4 6/3/23 - 7/2/23	359.30	823,208.84
06/28/2023	1189	Duval's Cleanest LLC	Pressure Washing Pillars & Entrance Sign	500.00	822,708.84
06/28/2023	1190	Magnetix DJ Services	MC/DJ Member Independence Pool Party	400.00	822,308.84
06/28/2023	1191	Screening One	Screening of Trainers	180.00	822,128.84
06/28/2023	1192	Tampa Print Services, Inc.	Printing Services	539.16	821,589.68
06/29/2023			Deposit	6,561.00	828,150.68
06/30/2023	0630ACH1	Comcast	13077 Beach Blvd. PEDESTRIAN GATE June 10, 2023 - July 9, 2023	199.35	827,951.33
06/30/2023			Service Charge	1.90	827,949.43
06/20/2023	100236	Poker Face Comedy, LLC	Invoice: 000014 (Reference: Comedian for Father's Day Brunch.)	Cancelled	-650.00
06/30/2023		EOM Balance		20,827.73	134,384.67
07/01/2023	1187	BNY Mellon Tax Distributions	Tax Distributions 2013A	118,057.53	710,541.90
07/01/2023	1188	BNY Mellon Tax Distributions	Tax Distributions 2015A	51,237.53	659,304.37
07/03/2023	68		Returned NSF check #319 dated 4/25/23 Wm Revels	200.00	659,104.37

07/03/2023	68		Returned NSF check #319 dated 4/25/23 Wm Revels - check fee		10.00	659,094.37
07/05/2023	100242	Jacksonville Daily Record	Invoice: 062223- (Reference: Legal Advertising.) Invoice: 062923- (Reference: Legal Advertisi..		625.00	658,469.37
07/05/2023	100243	Kutak Rock LLP	Invoice: 3239803 (Reference: General Counsel.)		2,985.50	655,483.87
07/05/2023	100244	Southeastern Paper Group	Invoice: 05935934 (Reference: Janitorial Supplies.)		457.84	655,026.03
07/05/2023	100245	TEKWave Solutions LLC	Invoice: 5804 (Reference: VMS - JULY.)		295.00	654,731.03
07/05/2023	100246	Vesta District Services	Invoice: 411076 (Reference: District Management Services.)		3,958.33	650,772.70
07/05/2023	100247	Ancient City Hardscapes, LLC	Invoice: 2020318 (Reference: Assorted Paver Repairs.)		475.00	650,297.70
07/05/2023	100248	Nathan Pokipala	Invoice: 1235 (Reference: 4th of July Entertainment.)		1,775.00	648,522.70
07/10/2023	100249	Southeastern Paper Group	Invoice: 05938316 (Reference: Supplies.)		179.92	648,342.78
07/10/2023	100250	Vesta Property Services	Invoice: 411576 (Reference: Amenity Services.)		32,532.91	615,809.87
07/10/2023	0710ACH1	GFL Environmental	Trash Service		178.03	615,631.84
07/12/2023	100251	Advanced Security Specialist & Consulting	Invoice: T0062023 (Reference: Security @ Tamaya 6/1 - 6/30/23.)		2,450.00	613,181.84
07/12/2023	100252	Sun State Nursery & Landscaping, Inc	Invoice: 10505 (Reference: June Landscape Maintenance.)		35,213.10	577,968.74
07/12/2023	100253	The Lake Doctors, Inc.	Invoice: 106688B (Reference: Water Management.)		1,767.00	576,201.74
07/12/2023	100254	VGlobal Tech	Invoice: 5218 (Reference: Email hosting.)		50.00	576,151.74
07/12/2023	100255	All Weather Contractors, Inc.	Invoice: 161697 (Reference: Plumbing Call Floor Drain Fitness Center.)		195.00	575,956.74
07/14/2023	100256	Advanced Security Specialist & Consulting	Invoice: T0062023B (Reference: 06.16.23 TO 06.30.23.)		9,300.00	566,656.74
07/14/2023	100257	Integrated Access Solutions	Invoice: 0003448 (Reference: Service Call.)		132.00	566,524.74
07/18/2023			Deposit	4,175.00		570,699.74
07/18/2023			Deposit	7,875.00		578,574.74
07/18/2023	0718ACH1	Comcast	12788 Meritace Blvd MINI MDTA 6/28/23 - 7/27/23		550.50	578,024.24
07/18/2023	0718ACH2	JEA	Service for the month of June		30,205.87	547,818.37
07/19/2023	1193	Maximum Entertainment Trivia	Monthly Trivia July 20th		200.00	547,618.37
07/19/2023	0719ACH1	TECO	12545 Beach Blvd - 5/24/23 - 6/22/23		36.35	547,582.02
07/19/2023			Account Closing Transfer	100.00		547,682.02
07/20/2023	0720ACH1	Comcast	12750 Meritage Blvd. GATEHOUSE 6/30/23 - 7/29/23		217.11	547,464.91
07/24/2023	0724ACH1	Florida Natural Gas	Fuel and Inside FGT Z3 5/23/23 - 6/22/23		10.28	547,454.63
07/24/2023	0724CC1	Credit Card transactions			2,464.79	544,989.84
07/25/2023			Deposit	192.36		545,182.20
07/25/2023	0725ACH1	Comcast	12788 Meritage Blvd. OFC 4 Jul 03, 2023 to Aug 02, 2023		359.30	544,822.90
07/26/2023	1194	Frederick Marshall Moore	Refund of Reservation		700.00	544,122.90
07/26/2023	1195	Chance Wedderburn	BOS Meeting 7/17/23		200.00	543,922.90
07/26/2023	1196	Elena Korsakova	BOS Meeting 7/17/23		200.00	543,722.90
07/26/2023	1197	Matthew Calderaro	BOS Meeting 7/17/23		200.00	543,522.90
07/26/2023	1198	Robert Renn	BOS Meeting 7/17/23		200.00	543,322.90
07/26/2023	1199	Shelia Papelbon	BOS Meeting 7/17/23		200.00	543,122.90
07/26/2023	100258	Advanced Security Specialist & Consulting	Invoice: T0072023A (Reference: 07.01.23 TO 07.15.23.)		9,300.00	533,822.90
07/26/2023	100259	Custom Pump & Controls, Inc.	Invoice: 51318 (Reference: COJ OWNERS SIGN.) Invoice: 23-314-03 (Reference: QUARTERI		445.63	533,377.27
07/26/2023	100260	Integrated Access Solutions	Invoice: 0003505 (Reference: BAI Barcodes Black on Black.)		383.78	532,993.49
07/26/2023	100261	Southeastern Paper Group	Invoice: 05946343 (Reference: Supplies.)		398.05	532,595.44
07/26/2023	100262	TEKWave Solutions LLC	Invoice: 5848 (Reference: VMS - August.)		295.00	532,300.44
07/31/2023	0731ACH1	Comcast	13077 Beach Blvd. PEDESTRIAN GATE July 10, 2023 - Aug 9, 2023		199.35	532,101.09
07/31/2023			Service Charge		1.60	532,099.49
7/31/2023	EOM Balance			12,342.36	308,842.30	532,099.49

EXHIBIT 9

Beach
Community Development District

Financial Statements
(Unaudited)

Preliminary

August 31, 2023

Beach CDD
Balance Sheet
August 31, 2023

	<u>General Fund</u>	<u>Debt Service 2013A</u>	<u>Debt Service 2015A</u>	<u>Construction</u>	<u>Total</u>
1 ASSETS					
2 OPERATING ACCOUNT BU	\$ 472,589	\$ -	\$ -	\$ -	\$ 472,589
3 PAYPAL ACCOUNT BU	-	-	-	-	-
4 CHECKING ACCOUNT CS	45,170	-	-	-	45,170
5 DEBT CARD ACCOUNT CS	893	-	-	-	893
6 DEBT SERVICE ACCOUNTS:					
7 SINKING FUND	-	-	-	-	-
8 INTEREST FUND	-	-	-	-	-
9 REDEMPTION FUND	-	37	150	-	187
10 PREPAYMENT FUND	-	65,942	80,112	-	146,054
11 REVENUE FUND	-	441,641	127,737	-	569,378
12 OP REDEMPTION FUND	-	-	-	-	-
13 ACQ & CONS 2013A	-	-	-	-	-
14 ACQ & CONS 2015A	-	-	-	-	-
15 ACCOUNTS RECEIVABLE	2,820	-	-	-	2,820
16 ASSESSMENTS RECEIVABLE ON-ROLL	-	-	92,938	-	92,938
17 ASSESSMENTS RECEIVABLE OFF-ROLL	-	-	-	-	-
18 DUE FROM OTHER FUNDS	-	4,376	2,011	-	6,387
19 PREPAID	3,966	-	-	-	3,966
20 TOTAL ASSETS	\$ 525,438	\$ 511,997	\$ 302,948	\$ -	\$ 1,340,382
21 LIABILITIES					
22 ACCOUNTS PAYABLE	\$ 71,913	\$ -	\$ -	\$ -	\$ 71,913
23 DEFERRED REVENUE ON-ROLL	-	-	-	-	-
24 DEFERRED REVENUE OFF-ROLL	-	-	92,938	-	92,938
25 DUE TO OTHER FUNDS	6,387	-	-	-	6,387
26 OUTSTANDING CHECKS	-	-	-	-	-
27 TOTAL LIABILITIES	78,300	-	92,938	-	171,239
28 FUND BALANCE					
29 NONSPENDABLE					
30 PREPAID & DEPOSITS	3,966	-	-	-	3,966
31 CAPITAL RESERVES	109,319	-	-	-	109,319
32 OPERATING CAPITAL	-	-	-	-	-
33 UNASSIGNED	333,852	511,997	210,010	-	1,055,858
34 TOTAL FUND BALANCE	447,137	511,997	210,010	-	1,169,143
35 TOTAL LIABILITIES & FUND BALANCE	\$ 525,438	\$ 511,997	\$ 302,948	\$ -	\$ 1,340,382

Beach CDD
General Fund
Statement of Revenue, Expenditures, and Changes in Fund Balance
For the period from October 1, 2022 to August 31, 2023

	FY 2023 Adopted Budget	FY 2023 Month of August	FY 2023 Total Actual Year-to-Date	VARIANCE Over (Under) to Budget	% Actual YTD / FY Budget
1 REVENUE					
2 ASSESSMENTS ON-ROLL	\$ 1,402,321	\$ -	\$ 1,408,715	\$ 6,395	100%
3 ASSESSMENTS OFF-ROLL	216,924	54,231	216,924	-	100%
4 INTEREST REVENUE	-	3	26	26	
5 OTHER FINANCING SOURCES	5,000	8,904	44,501	39,501	890%
6 CARRYFORWARD	-	-	-	-	
7 TOTAL REVENUE	\$ 1,624,245	\$ 63,139	\$ 1,670,167	\$ 45,922	103%
8 EXPENDITURES					
9 GENERAL & ADMINISTRATIVE EXPENSES					
10 TRUSTEE FEES	\$ 8,000	\$ -	\$ 8,200	\$ 200	103%
11 SUPERVISOR FEES-REGULAR MEETINGS	10,000	800	7,600	(2,400)	76%
12 SUPERVISOR FEES-WORKSHOPS	2,000	-	2,400	400	120%
13 DISTRICT MANAGEMENT	42,000	3,500	38,500	(3,500)	92%
14 ENGINEERING	2,500	-	2,157	(343)	86%
15 DISSEMINATION AGENT	2,500	-	2,500	-	100%
16 DISTRICT COUNSEL	7,500	2,290	22,266	14,766	297%
17 ASSESSMENT ADMINISTRATION	5,500	458	5,042	(458)	92%
18 REAMORTIZATION SCHEDULE	-	-	-	-	
19 ARBITRAGE REBATE CALCULATION	-	-	5,850	5,850	
20 AUDIT	6,000	-	3,250	(2,750)	54%
21 WEBSITE	1,515	187	2,338	823	154%
22 LEGAL ADVERTISING	1,750	210	4,841	3,091	277%
23 DUES, LICENSES & FEES	175	-	175	-	100%
24 GENERAL LIABILITY INSURANCE	4,057	-	-	(4,057)	0%
25 PUBLIC OFFICIAL INSURANCE	2,895	-	-	(2,895)	0%
26 OFFICE MISCELLANEOUS	2,000	206	8,437	6,437	422%
27 TOTAL GENERAL & ADMINISTRATIVE EXPENSES	98,392	7,651	113,555	15,163	115%
28 FIELD EXPENSES					
29 FIELD MANAGEMENT	133,553	9,921	106,709	(26,844)	80%
30 PROPERTY INSURANCE	89,054	-	88,097	(957)	99%
31 LAKE MAINTENANCE	21,600	1,767	18,693	(2,907)	87%
32 LANDSCAPING (INCLUDING MATERIALS)	402,792	-	291,392	(111,400)	72%
33 IRRIGATION (REPAIRS)	10,000	-	4,933	(5,067)	49%
34 ELECTRIC - STREET LIGHTS/IRRIGATION-JEA	188,475	21,176	229,212	40,737	122%
35 RIGHT OF WAY / LAKE MOWING	2,500	-	-	(2,500)	0%
36 ENTRY WATER FEATURE	7,500	-	-	(7,500)	0%
37 CARRYFORWARD REPLENISH	-	-	-	-	
38 CONTINGENCY - HURRICANE / STORM CLEAN UP	8,000	-	-	(8,000)	0%
39 COMMUNITY MAINTENANCE	8,000	3,866	20,248	12,248	253%
40 CAPITAL IMPROVEMENTS	39,080	-	3,575	(35,505)	9%
41 TOTAL FIELD EXPENSES	910,554	36,731	762,859	(147,695)	84%

42 AMENITY EXPENSES						
43	AMENITY MANAGEMENT	154,556	8,680	109,180	(45,376)	71%
44	BREEZEWAY STAFF	-	2,332	3,367	3,367	
45	LIFEGUARD	-	4,786	30,586	30,586	
46	SWIMMING POOL CHEMICALS	-	5,131	20,040	20,040	
47	SWIMMING POOL INSPECTION	-	-	851	851	
48	AMENITY GENERAL MAINTENANCE & REPAIRS	21,510	3,838	16,433	(5,077)	76%
49	AMENITY CLEANING	-	2,157	16,720	16,720	
50	AMENITY ELECTRIC/WATER AND SEWER	60,000	4,546	45,973	(14,027)	77%
51	AMENITY GATES/CONTROL ACCESS	5,000	1,248	13,418	8,418	268%
52	AMENITY WEBSITE/COMPUTER EQUIPMENT	1,590	-	2,233	643	140%
53	AMENITY INTERNET/CABLE	10,000	1,124	12,429	2,429	124%
54	AMENITY DUES & LICENSES	850	-	459	(391)	54%
55	AMENITY SECURITY	800	2,205	13,138	12,338	1642%
56	FITNESS EQUIPMENT MAINTENANCE	10,000	485	2,102	(7,898)	21%
57	LIFESTYLES PROGRAMMING	25,000	7,633	30,009	5,009	120%
58	AMENITY GAS	600	48	608	8	101%
59	TENNIS COURT MAINTENANCE - 4 CLAY COURTS	14,500	-	13,187	(1,313)	91%
60	LANDSCAPING MAINTENANCE AMENITY CENTER	68,400	-	25,333	(43,067)	37%
61	LANDSCAPE IMPROVEMENT	2,500	-	-	(2,500)	0%
62	AMENITY IRRIGATION (REPAIRS)	1,500	-	-	(1,500)	0%
63	PEST CONTROL	1,200	115	1,236	36	103%
64	AMENITY FIRE SYSTEM MONITORING	1,500	-	1,481	(19)	99%
65	ALARM	500	-	-	(500)	0%
66	TRASH COLLECTION	2,292	230	2,045	(247)	89%
67	TOTAL AMENITY EXPENSES	382,298	44,559	360,828	(21,470)	94%
68 ACCESS CONTROL /GATE HOUSE						
69	GUARD SERVICE	222,400	18,600	215,670	(6,730)	97%
70	GUARD HOUSE SUPPLIES	800	-	551	(249)	69%
71	GUARD HOUSE UTILITIES	3,800	199	2,778	(1,022)	73%
72	GUARD HOUSE REPAIR & MAINTENANCE	1,000	-	2,233	1,233	223%
73	BAR CODE EXPENSE	5,000	-	2,847	(2,153)	57%
74	TOTAL ACCESS CONTROL/GATE HOUSE EXPENSES	233,000	18,799	224,079	(8,921)	96%
75	TOTAL EXPENDITURES	1,624,245	107,740	1,461,322	(162,923)	90%
76	EXCESS OF REVENUE OVER (UNDER) EXPENDITURES	-	(44,601)	208,845	208,845	
77 OTHER FINANCING SOURCES & USES						
78	TRANSFER IN	-	-	-	-	
79	TRANSFER OUT	-	-	-	-	
80	TOTAL OTHER FINANCING SOURCES & USES	-	-	-	-	
81	FUND BALANCE - BEGINNING	239,612		238,292	(1,320)	
82	NET CHANGE IN FUND BALANCE	-	(44,601)	208,845	208,845	
83	FUND BALANCE - ENDING	\$ 239,612		\$ 447,137	\$ 207,525	
84 ANALYSIS OF FUND BALANCE						
85	NONSPENDABLE					
86	PREPAID & DEPOSITS	3,966		3,966		
87	CAPITAL RESERVES	109,319		109,319		
88	OPERATING CAPITAL	-		-		
89	UNASSIGNED	126,327		333,852		
90	TOTAL FUND BALANCE	\$ 239,612		\$ 447,137		

Beach CDD
Debt Service 2013A
Statement of Revenue, Expenditures, and Changes in Fund Balance
For the period from October 1, 2022 to August 31, 2023

	FY 2023 Adopted Budget	FY 2023 Actual Year-to-Date	VARIANCE Over (Under) to Budget
1 REVENUE			
2 ASSESSMENTS ON-ROLL	\$ 800,640	\$ 801,848	\$ 1,208
3 INTEREST REVENUE	-	8,761	8,761
4 MISC. REVENUE	-	80,614	80,614
5 TOTAL REVENUE	800,640	891,223	90,583
6 EXPENDITURES			
7 INTEREST EXPENSE			
8 November 1, 2022	-	313,908	313,908
9 May 1, 2023	313,920	311,425	(2,495)
10 November 1, 2023	308,058	-	(308,058)
11 PRINCIPAL RETIREMENT			
12 May 1, 2023	175,000	175,000	-
PRINCIPAL PREPAYMENT	-	85,000	85,000
13 TOTAL EXPENDITURES	796,978	885,333	(88,355)
14 EXCESS OF REVENUE OVER (UNDER) EXPENDITURES	3,663	5,891	2,228
15 OTHER FINANCING SOURCES (USES)			
16 TRANSFER IN	-	37	37
17 TRANSFER OUT (USES)	-	-	-
18 TOTAL OTHER FINANCING SOURCES (USES)	-	37	37
19 FUND BALANCE - BEGINNING	496,223	506,069	9,846
20 NET CHANGE IN FUND BALANCE	3,663	5,928	2,265
21 FUND BALANCE - ENDING	\$ 499,886	\$ 511,997	\$ 12,111

Beach CDD
Debt Service 2015A
Statement of Revenue, Expenditures, and Changes in Fund Balance
For the period from October 1, 2022 to August 31, 2023

	FY 2023 Adopted Budget	FY 2023 Actual Year-to-Date	VARIANCE Over (Under) to Budget
1 REVENUE			
2 ASSESSMENTS ON-ROLL	\$ 366,911	\$ 368,556	\$ 1,646
3 ASSESSMENTS OFF-ROLL	232,345	139,257	(93,087)
4 INTEREST REVENUE	-	1,177	1,177
5 MISC. REVENUE	-	76,873	76,873
6 TOTAL REVENUE	599,255	585,863	(13,392)
7 EXPENDITURES			
8 INTEREST EXPENSE			
9 November 1, 2022	-	221,988	221,988
10 May 1, 2023	221,988	221,988	-
11 November 1, 2023	217,268	-	(217,268)
12 PRINCIPAL RETIREMENT			
13 May 1, 2023	160,000	165,000	5,000
14 TOTAL EXPENDITURES	599,255	608,975	(9,720)
15 EXCESS OF REVENUE OVER (UNDER) EXPENDITURES	-	(23,112)	(23,112)
16 OTHER FINANCING SOURCES (USES)			
17 TRANSFER IN	-	149	149
18 TRANSFER OUT (USES)	-	-	-
19 TOTAL OTHER FINANCING SOURCES (USES)	-	149	149
20 FUND BALANCE - BEGINNING	96,818	232,972	136,154
21 NET CHANGE IN FUND BALANCE	-	(22,962)	(22,962)
22 FUND BALANCE - ENDING	\$ 96,818	\$ 210,010	\$ 113,192

Beach CDD Check Register - FY2023

Date	Ref. Num	Name	Memo	Deposits	Disbursements	Balance
09/30/2022		EOY Balance				295,536.89
10/01/2022	1114	Egis Insurance and Risk Advisors	FY Insurance Policy # 100122192 10/01/22-10/01/23		88,097.00	207,439.89
10/11/2022	1118	Kristin A. Robinson, MD	Refund of Deposit for rental of Pool Cabana		50.00	207,389.89
10/11/2022	100036	Advanced Security Specialist & Consulting	Invoice: T0092022A (Reference: Guard House Gate Access Management.)		8,370.00	199,019.89
10/11/2022	100037	Air Solutions Heating & Cooling Inc	Invoice: 0000094932 (Reference: Installed a new condenser fan motor, fan blade, and capacitor.)		2,038.39	196,981.50
10/11/2022	100038	Integrated Access Solutions	Invoice: 0001453 (Reference: Installation of Indoor Access Point.) Invoice: 0001472 (Referenc..		459.89	196,521.61
10/11/2022	100039	Life Fitness	Invoice: 7173030 (Reference: Clutch Kit.)		62.45	196,459.16
10/11/2022	100040	Southeast Fitness	Invoice: 100493 (Reference: Semi-annually scheduled preventative maintenance.)		640.00	195,819.16
10/11/2022	100041	Southeastern Paper Group	Invoice: 05717495 (Reference: Supplies.)		423.90	195,395.26
10/11/2022	100042	Staples	Invoice: 8067623768 (Reference: Office Supplies.)		48.07	195,347.19
10/11/2022	100043	Sun State Nursery & Landscaping, Inc	Invoice: 7821 (Reference: Irrigation Repairs.) Invoice: 7911 (Reference: Installation of Clock...		2,236.49	193,110.70
10/11/2022	100044	Wayne Automatic Fire Sprinklers Inc.	Invoice: 952684 (Reference: Annual Extinguisher Certification Inspection.)		352.61	192,758.09
10/14/2022	100045	10-S Tennis Supply & Dinkshot Pickleball	Invoice: 156365 (Reference: Aluminum Drag Broom.) Invoice: 156337 (Reference: 10-S Linesr		437.61	192,320.48
10/14/2022	100046	Advanced Security Specialist & Consulting	Invoice: T0092022B (Reference: Guard House Gate Access Management.) Invoice: TA0092022		12,570.00	179,750.48
10/14/2022	100047	Innersync	Invoice: 20817 (Reference: Website Services.)		1,515.00	178,235.48
10/14/2022	100048	Sun State Nursery & Landscaping, Inc	Invoice: 7986 (Reference: October Landscape Maintenance.)		35,213.10	143,022.38
10/14/2022	100050	The Lake Doctors, Inc.	Invoice: 36532B (Reference: Water Management Zone 1 & 2.)		1,395.00	141,627.38
10/14/2022	100051	Turner Pest Control	Invoice: 19160304 (Reference: Monthly pest control.)		104.74	141,522.64
10/14/2022	100052	Vesta Property Services	Invoice: 403326 (Reference: September Fees.)		19,605.00	121,917.64
10/14/2022	100053	VGlobal Tech	Invoice: 4366 (Reference: Email hosting.)		50.00	121,867.64
10/14/2022	101422ACH1	JEA	Service for the month of September		27,918.90	93,948.74
10/15/2022	101522ACH1	Comcast	12788 Meritace Blvd MINI MDTA 9/28/22 to 10/27/22		535.58	93,413.16
10/17/2022	1119	Dominik Guess	Refund for Rental Cancellation		200.00	93,213.16
10/17/2022	1120	Instant PhotoCube	80's Casino Night		475.00	92,738.16
10/17/2022	101722ACH1	Comcast	12750 Meritage Blvd. GATEHOUSE 9/30-10/29/22		212.20	92,525.96
10/18/2022	101822ACH1	TECO	12545 Beach Blvd - 8/19/22 - 9/20/22		37.07	92,488.89
10/20/2022			Deposit	1,749.54		94,238.43
10/21/2022	102122ACH1	Florida Natural Gas	Fuel and Inside FGT Z3 8/19/22 - 9/18/22		17.79	94,220.64
10/22/2022	102222ACH1	Comcast	12788 Meritage Blvd. OFC 4 10/3-11/2/22		351.09	93,869.55
10/23/2022	ACH 102322	Credit Card transactions			693.49	93,176.06
10/24/2022	100054	Advanced Security Specialist & Consulting	Invoice: T0102022A (Reference: Guard House Gate Access Management.)		8,100.00	85,076.06
10/24/2022	100055	Integrated Access Solutions	Invoice: 0001945 (Reference: Service call.) Invoice: 0001950 (Reference: Service Call.) In...		900.00	84,176.06
10/24/2022	100056	Life Fitness	Invoice: 7195361 (Reference: Seat Pad.)		117.75	84,058.31
10/24/2022	100057	Southeastern Paper Group	Invoice: 05660098 (Reference: Paper Supplies.)		355.77	83,702.54
10/24/2022	100058	Staples	Invoice: 8067869974 (Reference: Office Supplies.)		400.17	83,302.37
10/26/2022	100059	Integrated Access Solutions	Invoice: 0001465 (Reference: Labor for installation, setup and testing.)		360.00	82,942.37
10/27/2022	102722ACH1	Comcast	13077 Beach Blvd. PEDESTRIAN GATE 10/10 -11/9/22		194.35	82,748.02
10/31/2022			Service Charge		1.45	82,746.57
10/31/2022		EOM Balance		1,749.54	214,539.86	82,746.57
11/03/2022			Deposit	3,000.00		85,746.57
11/07/2022	100060	DPFG M&C	Invoice: 403568 (Reference: Dissemination Agent.) Invoice: 403505 (Reference: District Manag		6,458.33	79,288.24
11/07/2022	100061	Advanced Security Specialist & Consulting	Invoice: TA0102022 (Reference: Amenities security.) Invoice: T0102022B (Reference: Guard H		11,070.00	68,218.24
11/07/2022	100062	Big Z Pool Service, LLC	Invoice: 11382 (Reference: Comp Pool, VFD Drive.)		1,970.00	66,248.24
11/07/2022	100063	Custom Pump & Controls, Inc.	Invoice: 22-314-04 (Reference: QUARTERLY LIFT STATION INSPECTION.)		150.00	66,098.24
11/07/2022	100064	GFL Environmental	Invoice: UG0000080959 (Reference: Nov 01/22 - Nov 30/22.)		162.01	65,936.23
11/07/2022	100065	Integrated Access Solutions	Invoice: 0002027 (Reference: BAI Barcodes Black on Black.) Invoice: 0002035 (Reference: ped		1,740.01	64,196.22
11/07/2022	100066	Kutak Rock LLP	Invoice: 3126899 (Reference: General Counsel.)		1,320.00	62,876.22

11/07/2022	100067	Sun State Nursery & Landscaping, Inc	Invoice: 8275 (Reference: Irrigation Repairs.) Invoice: 8273 (Reference: Irrigation Repairs. ...		779.17	62,097.05
11/07/2022	100068	TEKWave Solutions LLC	Invoice: 102622- (Reference: VMS - November 2022.)		295.00	61,802.05
11/07/2022	100069	Turner Pest Control	Invoice: 19363970 (Reference: Commercial Pest Control.)		104.74	61,697.31
11/07/2022	100070	VGlobal Tech	Invoice: 4416 (Reference: Email hosting.)		50.00	61,647.31
11/07/2022	100071	Wayne Automatic Fire Sprinklers Inc.	Invoice: 998491 (Reference: Annual Sprinkler Inspection.)		309.38	61,337.93
11/14/2022	1121	Matthew Calderaro	BOS MTG 11/7/22		200.00	61,137.93
11/14/2022	1122	Robert Renn	BOS MTG 11/7/22		200.00	60,937.93
11/14/2022	1123	Shelia Papelbon	BOS MTG 11/7/22		200.00	60,737.93
11/14/2022	1124	Stefanos Kounoupas	BOS MTG 11/7/22		200.00	60,537.93
11/16/2022	111622ACH1	JEA	Service for the month of October		23,682.22	36,855.71
11/17/2022			Deposit	187,055.02		223,910.73
11/17/2022	111722ACH1	TECO	12545 Beach Blvd - 09/21/2022 to 10/20/2022		37.08	223,873.65
11/18/2022	111822ACH1	Comcast	12788 Meritace Blvd MINI MDTA 10/28/22 to 11/27/22		534.81	223,338.84
11/21/2022	ACH11/21/22	Florida Natural Gas	Fuel and Inside FGT Z3 9/20/22 -10/20/22		15.19	223,323.65
11/21/2022	1125	FLORIDA DEPT OF ECONOMIC OPPORTUNIT	FY 2022/2023 Special District Fee Invoice/Update Form		175.00	223,148.65
11/21/2022	100072	Integrated Access Solutions	Invoice: 0002123 (Reference: Emergency Service Call.)		180.00	222,968.65
11/21/2022	100073	Game Time Game Truck, LLC	Invoice: 3014 (Reference: 2 Hour Game Truck.)		504.00	222,464.65
11/21/2022	100074	DPFG M&C	Invoice: 404412 (Reference: District Management Services.)		3,958.33	218,506.32
11/21/2022	100075	Sun State Nursery & Landscaping, Inc	Invoice: 8366 (Reference: November Landscape Maintenance.) Invoice: 8274 (Reference: Irrigat		35,533.06	182,973.26
11/21/2022	100076	The Lake Doctors, Inc.	Invoice: 45252B (Reference: Water Management Zone 1 & 2.)		1,395.00	181,578.26
11/21/2022	112122ACH1	Comcast	12750 Meritage Blvd. GATEHOUSE10/30/22 to 11/29/22		211.88	181,366.38
11/22/2022			Deposit	54,231.04		235,597.42
11/23/2022			Deposit	192.36		235,789.78
11/23/2022	ACH 112322	Credit Card transactions			1,245.71	234,544.07
11/25/2022			Deposit	284,806.31		519,350.38
11/25/2022	112522ACH1	Comcast	12788 Meritage Blvd. OFC 4 11/3/22 - 12/2/22		351.09	518,999.29
11/30/2022	113022ACH1	Comcast	13077 Beach Blvd. PEDESTRIAN GATE 11/10/22 to 12/9/22		194.35	518,804.94
11/30/2022			Service Charge		1.70	518,803.24
11/30/2022	EOM Balance			529,284.73	93,228.06	518,803.24
12/02/2022	100077	Vesta Property Services	Invoice: 404248 (Reference: October Fees.)		20,846.14	497,957.10
12/05/2022			Deposit	1,346,682.83		1,844,639.93
12/06/2022			Deposit	1,950.00		1,846,589.93
12/06/2022			Deposit	215,761.07		2,062,351.00
12/12/2022	100078	10-S Tennis Supply & Dinkshot Pickleball	Invoice: 157124 (Reference: Pro-Screen Open Mesh.)		882.34	2,061,468.66
12/12/2022	100079	Advanced Security Specialist & Consulting	Invoice: T0112022A (Reference: Guard House Gate Access Management.)		9,300.00	2,052,168.66
12/12/2022	100080	Bob's Backflow & Plumbiong Services	Invoice: 87517 (Reference: Backflow Test.)		450.00	2,051,718.66
12/12/2022	100081	Integrated Access Solutions	Invoice: 0002199 (Reference: Wireless HDMI adapter.)		369.00	2,051,349.66
12/12/2022	100083	Kutak Rock LLP	Invoice: 113022-23-1 (Reference: General Counsel.)		4,558.50	2,046,791.16
12/12/2022	100084	Southeast Fitness	Invoice: 100363 (Reference: 9/6/2022 Diagnosis or Repair.)		150.00	2,046,641.16
12/12/2022	100085	Southeastern Paper Group	Invoice: 05773688 (Reference: ECO-AIR.)		53.32	2,046,587.84
12/12/2022	100086	Sun State Nursery & Landscaping, Inc	Invoice: 8551 (Reference: Fix Breaks on the back side of wall.) Invoice: 8550 (Reference: Irr...		36,036.41	2,010,551.43
12/12/2022	100087	TEKWave Solutions LLC	Invoice: 5414 (Reference: December 2022.)		295.00	2,010,256.43
12/12/2022	100088	The Lake Doctors, Inc.	Invoice: 670593 (Reference: Monthly Water Management Service.) Invoice: 57370b (Reference:		3,095.00	2,007,161.43
12/12/2022	100089	Turner Pest Control	Invoice: 19972952 (Reference: Pest Control.)		104.74	2,007,056.69
12/12/2022	100090	Vesta Property Services	Invoice: 405450 (Reference: November Fees.)		19,793.78	1,987,262.91
12/12/2022	100091	VGlobal Tech	Invoice: 4492 (Reference: Email hosting.)		50.00	1,987,212.91
12/12/2022	100092	The Perfect Pour	Invoice: 0000151A (Reference: Bar Service for Halloween Party 10/21/22.)		625.00	1,986,587.91
12/12/2022	100093	Daytona Beach News-Journal	Invoice: 0005017635 (Reference: Oct 1 - Oct 31, 2022.)		1,003.25	1,985,584.66
12/13/2022	1126	Matthew Calderaro	BOS MTG 12/5/22		200.00	1,985,384.66
12/13/2022	1127	Robert Renn	BOS MTG 12/5/22		200.00	1,985,184.66
12/13/2022	1128	Shelia Papelbon	BOS MTG 12/5/22		200.00	1,984,984.66
12/14/2022			Deposit	192.36		1,985,177.02

12/14/2022	121422ACH1	JEA	Service for the month of November		25,621.04	1,959,555.98
12/16/2022			Deposit	165,311.36		2,124,867.34
12/19/2022	121922ACH1	Comcast	12788 Meritace Blvd MINI MDTA 11/28/22 - 12/27/22		534.81	2,124,332.53
12/20/2022	122022ACH1	Comcast	12750 Meritage Blvd. GATEHOUSE11/30/22 to 12/29/22		211.88	2,124,120.65
12/20/2022	122022ACH2	TECO	12545 Beach Blvd - 10/20/2022 -11/28/22		37.70	2,124,082.95
12/22/2022	122222ACH1	Florida Natural Gas	Fuel and Inside FGT Z3 10/20/22 to 11/28/22		14.35	2,124,068.60
12/23/2022	100094	DPFG M&C	Invoice: 405570 (Reference: District Management Services.)		3,958.33	2,120,110.27
12/23/2022	100095	Advanced Security Specialist & Consulting	Invoice: TA0112022 (Reference: Amenities security.) Invoice: T0112022B (Reference: Guard H		11,460.00	2,108,650.27
12/23/2022	100096	Integrated Access Solutions	Invoice: 0002285 (Reference: Gate Repair.) Invoice: 0002291 (Reference: Guard House Gate Ac		3,192.16	2,105,458.11
12/23/2022	100097	Southeastern Paper Group	Invoice: 05765238 (Reference: Supplies.) Invoice: 05748187 (Reference: Supplies.)		824.54	2,104,633.57
12/23/2022	100098	Staples	Invoice: 8068566313 (Reference: Office Supplies.)		383.73	2,104,249.84
12/23/2022	100099	Vesta Property Services	Invoice: 403470 (Reference: Billable Expenses.)		3,170.38	2,101,079.46
12/23/2022	100100	Daytona Beach News-Journal	Invoice: 0005119397 (Reference: Advertising.)		1,324.92	2,099,754.54
12/23/2022	ACH 122322	Credit Card transactions			301.35	2,099,453.19
12/27/2022	1129	Matthew Calderaro	BOS MTG 12/19/22		200.00	2,099,253.19
12/27/2022	1130	Robert Renn	BOS MTG 12/19/22		200.00	2,099,053.19
12/27/2022	1131	Shelia Papelbon	BOS MTG 12/19/22		200.00	2,098,853.19
12/27/2022	1132	Stefanos Kounoupas	BOS MTG 12/19/22		200.00	2,098,653.19
12/27/2022	122722ACH1	Comcast	12788 Meritage Blvd. OFC 4 12/3/22 - 1/2/23		351.09	2,098,302.10
12/28/2022	1133	DPFG M&C	August Billable Expenses		30.63	2,098,271.47
12/30/2022			Deposit	308.38		2,098,579.85
12/30/2022	123022ACH1	Comcast	13077 Beach Blvd. PEDESTRIAN GATE 12/10/22 to 1/9/23		194.35	2,098,385.50
12/31/2022			Service Charge		1.75	2,098,383.75
12/31/2022	EOM Balance			1,730,206.00	150,625.49	2,098,383.75
01/03/2023	1135	Magnetix DJ Services	Reference: Emcee & DJ Polar Plunge. https://dpfg.payableslockbox.com/DocView/InvoiceViewer		400.00	2,097,983.75
01/03/2023	1136	Shannon Brooke Thomas	Reference: Halloween Paint and Sip Event. https://dpfg.payableslockbox.com/DocView/InvoiceVi		150.00	2,097,833.75
01/03/2023	1137	Art-Z-Faces, Inc.	Reference: Santa Appearance. <a "="" href="https://dpfg.payableslockbox.com/DocView/InvoiceViewer.aspx?i=">https://dpfg.payableslockbox.com/DocView/InvoiceViewer.aspx?i=		300.00	2,097,533.75
01/03/2023	100101	Advanced Security Specialist & Consulting	Invoice: T0122022A (Reference: Guard House Gate Access Management.)		9,000.00	2,088,533.75
01/03/2023	100102	Southeastern Paper Group	Invoice: 05783796 (Reference: Supplies.)		258.71	2,088,275.04
01/03/2023	100103	Vesta Property Services	Invoice: 404351 (Reference: Billable Expenses.)		2,894.83	2,085,380.21
01/03/2023	100104	Daytona Beach News-Journal	Invoice: 0005097697 (Reference: Advertising.)		14.83	2,085,365.38
01/04/2023			Deposit	875.00		2,086,240.38
01/05/2023	1140	BNY Mellon Tax Distributions	Tax Distributions 2013A		689,260.69	1,396,979.69
01/05/2023	1141	BNY Mellon Tax Distributions	Tax Distributions 2015A		316,807.18	1,080,172.51
01/06/2023			Deposit	79,101.86		1,159,274.37
01/09/2023			Deposit	54,231.04		1,213,505.41
01/09/2023	100105	Advanced Security Specialist & Consulting	Invoice: TA0122022 (Reference: Amenities security.) Invoice: T0122022B (Reference: Guard H		12,060.00	1,201,445.41
01/09/2023	100106	Bob's Backflow & Plumbiong Services	Invoice: 88072 (Reference: Backflow Test.)		227.49	1,201,217.92
01/09/2023	100107	Integrated Access Solutions	Invoice: 0002350 (Reference: Service Call.) Invoice: 0001921 (Reference: Comcast modem bad		272.00	1,200,945.92
01/09/2023	100108	Kutak Rock LLP	Invoice: 3158252 (Reference: General Counsel.)		1,092.50	1,199,853.42
01/09/2023	100109	Sun State Nursery & Landscaping, Inc	Invoice: 8943 (Reference: January Landscape Maintenance.)		35,213.10	1,164,640.32
01/09/2023	100110	TEKWave Solutions LLC	Invoice: 5467 (Reference: Community Visitor Management Software.)		295.00	1,164,345.32
01/09/2023	100111	The Lake Doctors, Inc.	Invoice: 63731B (Reference: Water Management.)		1,767.00	1,162,578.32
01/09/2023	100112	Turner Pest Control	Invoice: 20497453 (Reference: Commercial Pest Control.)		104.74	1,162,473.58
01/09/2023	100113	VGlobal Tech	Invoice: 4623 (Reference: Email hosting.)		50.00	1,162,423.58
01/09/2023	100114	Wayne Automatic Fire Sprinklers Inc.	Invoice: 1014988 (Reference: WayneNet Fire Alarm Monitoring.)		750.00	1,161,673.58
01/09/2023	100115	Oxi Fresh Carpet Cleaning	Invoice: 1050 (Reference: Tile and Grout & Carpet Cleaning.) Invoice: 1051 (Reference: Tile a.		2,355.25	1,159,318.33
01/09/2023	100116	Bouncers, Slides, and More Inc.	Invoice: 12152022.03 (Reference: Movie Night.) Invoice: 10082022.16 (Reference: Obstacle Cc		1,330.00	1,157,988.33
01/15/2023	11523ACH1	Comcast	12788 Meritace Blvd MINI MDTA 12/28/22 - 1/27/23		547.90	1,157,440.43
01/17/2023	11723ACH1	Comcast	12750 Meritage Blvd. GATEHOUSE12/30/22 to 1/29/23		215.97	1,157,224.46
01/17/2023	100117	DPFG M&C	Invoice: 404329 (Reference: October Billable Expenses.)		48.95	1,157,175.51
01/18/2023	11823ACH1	TECO	12545 Beach Blvd - 11/28/22 - 12/19/22		40.25	1,157,135.26

01/18/2023			Deposit	192.36		1,157,327.62
01/19/2023	11922ACH1	JEA	Service for the month of December		27,981.75	1,129,345.87
01/20/2023	100118	DPFG M&C	Invoice: 406418 (Reference: December Billable Expenses.) Invoice: 406478 (Reference: District		4,104.61	1,125,241.26
01/20/2023	100119	Integrated Access Solutions	Invoice: 0002427 (Reference: Labor for installation, setup and testing.)		899.63	1,124,341.63
01/20/2023	100121	Sun State Nursery & Landscaping, Inc	Invoice: 8548 (Reference: Irrigation Repairs made during Inspection.)		142.18	1,124,199.45
01/20/2023	100122	Coastal Maintenance M.E. LLC	Invoice: 4165 (Reference: Holiday Lights.)		5,578.00	1,118,621.45
01/22/2023	12223ACH1	Comcast	12788 Meritage Blvd. OFC 4 1/3/23 - 2/2/23		361.28	1,118,260.17
01/23/2023	ACH012323	Florida Natural Gas	Fuel and Inside FGT Z3 11/28/22 to 12/19/22		23.99	1,118,236.18
01/23/2023	1142	Chance Wedderburn	BOS MTG 1/16/23		200.00	1,118,036.18
01/23/2023	1143	Matthew Calderaro	BOS MTG 1/16/23		200.00	1,117,836.18
01/23/2023	1144	Robert Renn	BOS MTG 1/16/23		200.00	1,117,636.18
01/23/2023	1145	Shelia Papelbon	BOS MTG 1/16/23		200.00	1,117,436.18
01/23/2023	1151	Stefanos Kounoupas	BOS MTG 1/16/23		200.00	1,117,236.18
01/23/2023	ACH 012323	Credit Card transactions			908.87	1,116,327.31
01/24/2023	1152	Brian T. Shirley	Stand-Up Comedy Show for Valentine's Day Cocktail Party		400.00	1,115,927.31
01/24/2023	1153	Ebony Lunsford	Cocktail Service		500.00	1,115,427.31
01/24/2023			Deposit	127,429.74		1,242,857.05
01/25/2023	100123	Advanced Security Specialist & Consulting	Invoice: T0012023A (Reference: Guard House Gate Access Management.)		9,300.00	1,233,557.05
01/25/2023	100124	Custom Pump & Controls, Inc.	Invoice: 23-314-01 (Reference: QUARTERLY LIFT STATION INSPECTION.)		150.00	1,233,407.05
01/25/2023	100125	E.T.M.	Invoice: 0206237 (Reference: Engineering Services.)		1,073.25	1,232,333.80
01/25/2023	100126	GFL Environmental	Invoice: UG0000087355 (Reference: Trash Service.)		193.73	1,232,140.07
01/25/2023	100127	Southeastern Paper Group	Invoice: 05806313 (Reference: PURELL HAND SANITIZING.)		175.71	1,231,964.36
01/25/2023	100128	Sun State Nursery & Landscaping, Inc	Invoice: 9019 (Reference: Irrigation Repairs Made During Monthly Inspection.)		151.79	1,231,812.57
01/25/2023	100129	Vesta Property Services	Invoice: 406387 (Reference: Billable Expenses.)		2,193.93	1,229,618.64
01/25/2023	100130	Daytona Beach News-Journal	Invoice: 0005202822 (Reference: Advertising.)		578.28	1,229,040.36
01/27/2023	1154	BNY Mellon Payment/Trustee Fees	Trustee Fees 2013A: November 01, 2022 to October 31, 2023		4,100.00	1,224,940.36
01/27/2023	1155	BNY Mellon Payment/Trustee Fees	Trustee Fees 2015A: November 01, 2022 to October 31, 2023		4,100.00	1,220,840.36
01/27/2023			Deposit	1,975.00		1,222,815.36
01/30/2023	1156	Magnetix DJ Services	Reference: Emcee & DJ Member Music Bingo Night		350.00	1,222,465.36
01/30/2023	13023ACH1	Comcast	13077 Beach Blvd. PEDESTRIAN GATE Jan 10, 2023 to Feb 09, 2023		199.35	1,222,266.01
01/31/2023			Service Charge		2.55	1,222,263.46
01/31/2023		EOM Balance		263,805.00	1,139,925.29	1,222,263.46
02/09/2023			Deposit	192.36		1,222,455.82
02/09/2023	100131	Advanced Security Specialist & Consulting	Invoice: T0012023B (Reference: Guard House Gate Access Management.)		9,600.00	1,212,855.82
02/09/2023	100132	Kutak Rock LLP	Invoice: 3170780 (Reference: General Counsel.)		1,897.50	1,210,958.32
02/09/2023	100133	Southeastern Paper Group	Invoice: 05817499 (Reference: Paper Supplies.)		297.63	1,210,660.69
02/09/2023	100134	Sun State Nursery & Landscaping, Inc	Invoice: 9158 (Reference: Valve Replacement.) Invoice: 9159 (Reference: Repair of break.) ...		36,225.90	1,174,434.79
02/09/2023	100135	TEKWave Solutions LLC	Invoice: 5523 (Reference: Visitor Management Software-JAN.)		295.00	1,174,139.79
02/09/2023	100136	The Lake Doctors, Inc.	Invoice: 72574B (Reference: Water Management.)		1,767.00	1,172,372.79
02/09/2023	100137	Turner Pest Control	Invoice: 20597624 (Reference: Pest Control.)		115.21	1,172,257.58
02/09/2023	100138	VGlobal Tech	Invoice: 4735 (Reference: Email:Email hosting.)		50.00	1,172,207.58
02/09/2023	100139	Community Advisors, LLC	Invoice: 1537 (Reference: Reserve Analysis.)		4,900.00	1,167,307.58
02/13/2023	100140	GFL Environmental	Invoice: UG000090424 (Reference: Trash Service.)		177.88	1,167,129.70
02/15/2023	21523ACH1	JEA	Service for the month of January		20,109.16	1,147,020.54
02/17/2023			Deposit	9,913.18		1,156,933.72
02/21/2023	22123ACH1	Comcast	12788 Meritace Blvd MINI MDTA 1/28/22 - 2/27/23		548.46	1,156,385.26
02/21/2023	22123ACH2	Comcast	12750 Meritage Blvd. GATEHOUSE1/30/23 to 2/28/23		216.20	1,156,169.06
02/21/2023	22123ACH3	TECO	12545 Beach Blvd - 12/20/22 - 1/23/23		56.44	1,156,112.62
02/23/2023	100141	Integrated Access Solutions	Invoice: 0002621 (Reference: Service Call.)		264.00	1,155,848.62
02/23/2023	100142	Southeastern Paper Group	Invoice: 05802879 (Reference: Paper Supplies.)		386.21	1,155,462.41
02/23/2023	100143	Vesta Property Services	Invoice: 406329 (Reference: December Fees.) Invoice: 405487 (Reference: Billable Expenses.)		46,194.31	1,109,268.10
02/23/2023	22323ACH1	Florida Natural Gas	Fuel and Inside FGT Z3 12/19/22 - 1/23/23		42.56	1,109,225.54

02/23/2023	ACH 022323	Credit Card transactions		1,977.35	1,107,248.19
02/27/2023	100144	DPFG M&C	Invoice: 407496 (Reference: January Billable Expenses.) Invoice: 407582 (Reference: District ...	4,066.06	1,103,182.13
02/27/2023	100145	Advanced Security Specialist & Consulting	Invoice: T0022023A (Reference: Guard House Gate Access Management.) Invoice: TA0012023	10,980.00	1,092,202.13
02/27/2023	100146	Bob's Backflow & Plumbing Services	Invoice: 89479 (Reference: Backflow Test.)	225.00	1,091,977.13
02/27/2023	100147	GFL Environmental	Invoice: UG0000093668 (Reference: Trash Service.)	177.88	1,091,799.25
02/27/2023	100148	Integrated Access Solutions	Invoice: 0002655 (Reference: BAI Barcodes Black on Black.)	383.78	1,091,415.47
02/27/2023	100149	Sun State Nursery & Landscaping, Inc	Invoice: 9472 (Reference: Irrigation Repairs made during Inspection.)	493.19	1,090,922.28
02/27/2023	100150	Turner Pest Control	Invoice: 20704326 (Reference: Pest Control.)	115.21	1,090,807.07
02/27/2023	100151	Vesta Property Services	Invoice: 407489 (Reference: Billable Expenses.)	592.85	1,090,214.22
02/27/2023	1157	Chance Wedderburn	BOS MTG 2/20/23	200.00	1,090,014.22
02/27/2023	1158	Matthew Calderaro	BOS MTG 2/20/23	200.00	1,089,814.22
02/27/2023	1159	Robert Renn	BOS MTG 2/20/23	200.00	1,089,614.22
02/27/2023	1160	Shelia Papelbon	BOS MTG 2/20/23	200.00	1,089,414.22
02/27/2023	1161	Stefanos Kounoupas	BOS MTG 2/20/23	200.00	1,089,214.22
02/27/2023		Deposit		1,375.00	1,090,589.22
02/27/2023		Deposit		3,297.16	1,093,886.38
02/28/2023		Service Charge		1.40	1,093,884.98
02/28/2023	EOM Balance			14,777.70	143,156.18
03/01/2023	ACH030123	Bank United	Check 126 deposited 02/27 Chargeback Fee	35.00	1,093,849.98
03/02/2023	030223ACH1	Comcast	13077 Beach Blvd. PEDESTRIAN GATE 2/10/23 - 3/9/23	199.35	1,093,650.63
03/03/2023	1162	Live Entertainment Solutions, LLC	DJ for Trivia Night on 3/16/23 including supplies	275.00	1,093,375.63
03/06/2023		Deposit		6,849.03	1,100,224.66
03/08/2023		Deposit		192.36	1,100,417.02
03/09/2023	100152	Advanced Security Specialist & Consulting	Invoice: TA0022023 (Reference: Amenities security.) Invoice: T0022023B (Reference: Guard H	9,960.00	1,090,457.02
03/09/2023	100153	Kutak Rock LLP	Invoice: 3182997 (Reference: General Counsel.)	1,901.50	1,088,555.52
03/09/2023	100154	TEKWave Solutions LLC	Invoice: 5578 (Reference: Visitor Management Software.)	295.00	1,088,260.52
03/09/2023	100155	First Coast Mulch	Invoice: 4831 (Reference: Mulch Installation:Playground Chips.)	3,575.00	1,084,685.52
03/13/2023	100156	Southeastern Paper Group	Invoice: 05829171 (Reference: Supplies.)	376.43	1,084,309.09
03/13/2023	100157	Sun State Nursery & Landscaping, Inc	Invoice: 9616 (Reference: March Landscape Maintenance.)	35,213.10	1,049,095.99
03/13/2023	100158	The Lake Doctors, Inc.	Invoice: 76968B (Reference: Water Management.)	1,767.00	1,047,328.99
03/13/2023	100159	Vesta Property Services	Invoice: 408152 (Reference: Amenity Management.)	18,973.93	1,028,355.06
03/13/2023	100160	VGlobal Tech	Invoice: 4781 (Reference: Email hosting.)	50.00	1,028,305.06
03/13/2023	100161	Wayne Automatic Fire Sprinklers Inc.	Invoice: 1030521 (Reference: Annual Extinguisher Certification Inspection.) Invoice: 1030371 .	346.73	1,027,958.33
03/14/2023	1163	Matthew Calderaro	BOS MTG 3/09/23	200.00	1,027,758.33
03/14/2023	1164	Stefanos Kounoupas	BOS MTG 3/9/23	200.00	1,027,558.33
03/16/2023		Deposit		61,862.73	1,089,421.06
03/17/2023	31723ACH1	JEA	Service for the month of February	18,352.18	1,071,068.88
03/20/2023	ACH032023	TECO	12545 Beach Blvd - 1/24/23 - 2/21/23	41.09	1,071,027.79
03/20/2023	032023ACH1	Comcast	12750 Meritage Blvd. GATEHOUSE 3/01/23 to 3/29/23	216.20	1,070,811.59
03/20/2023	32023ACH2	Comcast	12788 Meritace Blvd MINI MDTA 2/28/22 - 3/27/23	548.42	1,070,263.17
03/23/2023	ACH032323	Florida Natural Gas	Fuel and Inside FGT Z3 1/23/23 - 2/21/23	16.08	1,070,247.09
03/23/2023	100162	DPFG M&C	Invoice: 408425 (Reference: District Management Services.) Invoice: 408367 (Reference: Billab	4,224.33	1,066,022.76
03/23/2023	100163	Advanced Security Specialist & Consulting	Invoice: T0032023A (Reference: Guard House Gate Access Management.)	9,000.00	1,057,022.76
03/23/2023	100165	Vesta Property Services	Invoice: 408342 (Reference: Billable Expenses.)	603.48	1,056,419.28
03/23/2023	ACH 032323	Credit Card transactions		2,530.22	1,053,889.06
03/27/2023	22723ACH1	Comcast	12788 Meritage Blvd. OFC 4 2/3/23 - 3/2/23	361.29	1,053,527.77
03/27/2023	1165	Chance Wedderburn	BOS MTG 3/20/23	200.00	1,053,327.77
03/27/2023	1166	Matthew Calderaro	BOS MTG 3/20/23	200.00	1,053,127.77
03/27/2023	1167	Robert Renn	BOS MTG 3/20/23	200.00	1,052,927.77
03/27/2023	1168	Shelia Papelbon	BOS MTG 3/20/23	200.00	1,052,727.77
03/27/2023	100166	GFL Environmental	Invoice: UG0000096764 (Reference: Trash Service.)	195.31	1,052,532.46
03/27/2023	100167	Integrated Access Solutions	Invoice: 0002826 (Reference: Installation, set-up & testing.)	1,383.00	1,051,149.46

03/27/2023	032723ACH1	Comcast	12788 Meritage Blvd. OFC 4 3/3/23 - 4/2/23		361.24	1,050,788.22
03/28/2023			Deposit	600.00		1,051,388.22
03/30/2023	030323ACH1	Comcast	13077 Beach Blvd. PEDESTRIAN GATE Mar 10, 2023 to Apr 09, 2023		199.35	1,051,188.87
03/31/2023	100168	Bob's Backflow & Plumbiong Services	Invoice: 90342 (Reference: replace the existing backflow preventer.)		1,597.00	1,049,591.87
03/31/2023	100169	Southeastern Paper Group	Invoice: 05856941 (Reference: Paper Supplisr.) Invoice: 05853072 (Reference: Paper Supplies.		423.65	1,049,168.22
03/31/2023	100170	Sun State Nursery & Landscaping, Inc	Invoice: 9802 (Reference: Irrigation Repairs.)		925.95	1,048,242.27
03/31/2023	100171	TEKWave Solutions LLC	Invoice: 5632 (Reference: VMS - APRIL.)		295.00	1,047,947.27
03/31/2023	100172	Turner Pest Control	Invoice: 617040310 ()		115.21	1,047,832.06
03/31/2023	100173	Beaches Electrical Service, Inc.	Invoice: 11802 (Reference: Service Call.)		187.50	1,047,644.56
03/31/2023			Service Charge		1.80	1,047,642.76
03/31/2023		EOM Balance		69,504.12	115,746.34	1,047,642.76
04/03/2023	1169	Weinglass Music	Musician 4/13/23		500.00	1,047,142.76
04/06/2023	100174	Advanced Security Specialist & Consulting	Invoice: TA0032023 (Reference: Amenities security.) Invoice: T0032023B (Reference: Guard H		12,330.00	1,034,812.76
04/06/2023	100175	Integrated Access Solutions	Invoice: 0002866 (Reference: Service call response to check Amenity NVR HDD.) Invoice: 000.		528.00	1,034,284.76
04/06/2023	100176	Life Fitness	Invoice: 7337480 (Reference: Parts.) Invoice: 7336389 (Reference: Parts.)		46.86	1,034,237.90
04/06/2023	100177	Southeast Fitness	Invoice: 101452 (Reference: Semi-annually scheduled preventative maintenance.)		640.00	1,033,597.90
04/06/2023	100178	Sun State Nursery & Landscaping, Inc	Invoice: 9947 (Reference: April Landscape Maintenance.)		35,213.10	998,384.80
04/06/2023	100179	The Lake Doctors, Inc.	Invoice: 84489B (Reference: Water Management.)		1,767.00	996,617.80
04/11/2023			Deposit	192.36		996,810.16
04/11/2023			Deposit	18,840.21		1,015,650.37
04/14/2023	100180	Custom Pump & Controls, Inc.	Invoice: 23-314-02 (Reference: QUARTERLY LIFT STATION INSPECTION.)		150.00	1,015,500.37
04/14/2023	100181	Integrated Access Solutions	Invoice: 0002934 (Reference: Main Control Board & Liftmaster Motor.)		1,308.91	1,014,191.46
04/14/2023	100182	Kutak Rock LLP	Invoice: 3197846 (Reference: Beach CDD - General Counsel.)		3,028.00	1,011,163.46
04/14/2023	100183	Southeastern Paper Group	Invoice: 05870004 (Reference: Supplies.)		568.49	1,010,594.97
04/14/2023	100184	Vesta Property Services	Invoice: 409165 (Reference: Amenity Management.) Invoice: 409239 (Reference: Billable Expe		21,301.36	989,293.61
04/14/2023	100185	VGloba Tech	Invoice: 4929 (Reference: Email hosting.)		50.00	989,243.61
04/14/2023	100186	JT's Home Solutions LLC	Invoice: 197 (Reference: Touch up painting - Fitness Room.)		750.00	988,493.61
04/17/2023	0417ACH1	JEA	Service for the month of March		21,430.34	967,063.27
04/18/2023	1170	The Perfect Pour	Event at Tamaya 4/13/23		450.00	966,613.27
04/18/2023	0418ACH1	Comcast	12788 Meritace Blvd MINI MDTA 3/28/22 - 4/27/23		548.42	966,064.85
04/19/2023	0419ACH1	TECO	12545 Beach Blvd - 2/22/23 - 3/22/23		36.35	966,028.50
04/19/2023			Deposit	3,451.56		969,480.06
04/20/2023			Deposit	54,231.04		1,023,711.10
04/20/2023	Wire042023	BNY Mellon Payment/Trustee Fees	Off Roll Assessment 2015A-1		139,418.70	884,292.40
04/20/2023	0420ACH1	Comcast	12750 Meritage Blvd. GATEHOUSE 3/30/23 - 4/29/23		216.20	884,076.20
04/20/2023			Deposit	139,406.70		1,023,482.90
04/21/2023	ACH042123	Florida Natural Gas	Fuel and Inside FGT Z3 2/23/23 - 3/22/23		10.23	1,023,472.67
04/24/2023	1171	Chance Wedderburn	BOS MTG 4/17/23		200.00	1,023,272.67
04/24/2023	1172	Matthew Calderaro	BOS MTG 4/17/23		200.00	1,023,072.67
04/24/2023	1173	Robert Renn	BOS MTG 4/17/23		200.00	1,022,872.67
04/24/2023	100187	Advanced Security Specialist & Consulting	Invoice: T0042023A (Reference: Guard House Gate Access Management.)		9,000.00	1,013,872.67
04/24/2023	100188	Big Z Pool Service, LLC	Invoice: 12240 (Reference: warranty sump pumps.)		392.00	1,013,480.67
04/24/2023	100189	Integrated Access Solutions	Invoice: 0002962 (Reference: Service Call Driveway resident entry barrier arm.) Invoice: 0002...		954.14	1,012,526.53
04/24/2023	100190	B.A.B Tennis Courts	Invoice: 1 (Reference: Tennis Center Resurfacing Project.)		5,950.00	1,006,576.53
04/24/2023	100191	Vesta District Services	Invoice: 409333 (Reference: District Management Services.)		3,958.33	1,002,618.20
04/24/2023	ACH 042423	Credit Card transactions			2,026.15	1,000,592.05
04/25/2023	0425ACH1	Comcast	12788 Meritage Blvd. OFC 4 4/3/23 - 5/2/23		361.24	1,000,230.81
04/27/2023			Deposit	1,320.00		1,001,550.81
04/30/2023			Service Charge		2.85	1,001,547.96
04/30/2023		EOM Balance		217,441.87	263,536.67	1,001,547.96
05/01/2023	1174	Chance Wedderburn	BOS Workshop 4/26/23		200.00	1,001,347.96
05/01/2023	1175	Matthew Calderaro	BOS Workshop 4/26/23		200.00	1,001,147.96

05/01/2023	1176	Robert Renn	BOS Workshop 4/26/23		200.00	1,000,947.96
05/01/2023	0501ACH1	Comcast	13077 Beach Blvd. PEDESTRIAN GATE Apr 09, 2023 to May 10, 2023		199.35	1,000,748.61
05/02/2023			Deposit	661.00		1,001,409.61
05/04/2023	100192	Magnetix DJ Services	Invoice: 3513 (Reference: Emcee & DJ Member Trivia Night.)		350.00	1,001,059.61
05/04/2023			Deposit	18,233.94		1,019,293.55
05/05/2023	100193	Advanced Security Specialist & Consulting	Invoice: T0042023B (Reference: Guard House Gate Access Management.) Invoice: TA0042023		11,520.00	1,007,773.55
05/05/2023	100194	Integrated Access Solutions	Invoice: 0003005 (Reference: Service Call.) Invoice: 0003024 (Reference: Service Call - Fitne...		411.00	1,007,362.55
05/05/2023	100195	Kutak Rock LLP	Invoice: 3211113 (Reference: General Counsel.)		1,938.00	1,005,424.55
05/05/2023	100196	TEKWave Solutions LLC	Invoice: 5684 (Reference: Visitor Management Software.)		295.00	1,005,129.55
05/05/2023	100197	The Lake Doctors, Inc.	Invoice: 91916B (Reference: Water Management.)		1,767.00	1,003,362.55
05/05/2023	100198	VGlobel Tech	Invoice: 5000 (Reference: Email hosting.)		50.00	1,003,312.55
05/05/2023	100199	SS Live Entertainment, LLC	Invoice: 2854 (Reference: Live Entertainment 4.22.23.)		500.00	1,002,812.55
05/05/2023	100200	Bouncers, Slides, and More Inc.	Invoice: 042423- (Reference: Bounce House & Obstacle Course.)		500.00	1,002,312.55
05/05/2023	100201	Beaches Electrical Service, Inc.	Invoice: 11957 (Reference: Service call on Fountain.)		125.00	1,002,187.55
05/05/2023	100202	Vesta District Services	Invoice: 409273 (Reference: Billable Expenses - March 2023.)		127.76	1,002,059.79
05/10/2023	01ACH051023	Florida Department of Health	Pool permit 16-60-1627485		325.35	1,001,734.44
05/10/2023	02ACH051023	Florida Department of Health	Pool permit 16-60-1627490		325.35	1,001,409.09
05/10/2023	03ACH051023	Florida Department of Health	Pool permit16-60-1679058		200.35	1,001,208.74
05/10/2023	0510ACH1	GFL Environmental	Trash Service		195.31	1,001,013.43
05/11/2023			Deposit	192.36		1,001,205.79
05/12/2023	1177	TEKWave Solutions LLC			1,180.00	1,000,025.79
05/12/2023	100203	Buehler Air Conditioning	Invoice: 106529 (Reference: Service Call.)		491.10	999,534.69
05/12/2023	100204	Jacksonville Daily Record	Invoice: 050423- (Reference: Advertising Supervisors Meeting.) Invoice: 041323- (Reference: .		282.76	999,251.93
05/12/2023	100205	Southeastern Paper Group	Invoice: 05895051 (Reference: Supplies.)		512.01	998,739.92
05/12/2023	100206	Sun State Nursery & Landscaping, Inc	Invoice: 10106 (Reference: Irrigation Repairs during Inspection.)		284.75	998,455.17
05/12/2023	100207	Vesta Property Services	Invoice: 410072 (Reference: Amenity Management.) Invoice: 410012 (Reference: Billable Expe		20,729.65	977,725.52
05/12/2023	100208	SS Live Entertainment, LLC	Invoice: 2860 (Reference: Live Entertainment 5/28 & 5/29/23.)		1,000.00	976,725.52
05/12/2023	100209	Trice Music Services, Inc.	Invoice: 00515 (Reference: Entertainment - May 27th.)		375.00	976,350.52
05/15/2023	1178	Chance Wedderburn	BOS Workshop 5/10/23		200.00	976,150.52
05/15/2023	1179	Matthew Calderaro	BOS Workshop 5/10/23		200.00	975,950.52
05/15/2023	1180	Robert Renn	BOS Workshop 5/10/23		200.00	975,750.52
05/15/2023	1181	Shelia Papelbon	BOS Workshop 5/10/23		200.00	975,550.52
05/16/2023			Deposit	361.00		975,911.52
05/16/2023	0516ACH1	JEA	Service for the month of April		25,925.31	949,986.21
05/18/2023	0518ACH1	Comcast	12788 Meritace Blvd MINI MDTA 4/28/22 - 5/27/23		548.20	949,438.01
05/19/2023	100210	LLS Tax Solutions, Inc.	Invoice: 003010 (Reference: Arbitrage Services.) Invoice: 003011 (Reference: Arbitrage Servic..		5,850.00	943,588.01
05/19/2023	0519ACH1	TECO	12545 Beach Blvd - 3/23/23 - 4/21/23		36.91	943,551.10
05/22/2023	1182	Chance Wedderburn	BOS Meeting 5/15/23		200.00	943,351.10
05/22/2023	1183	Matthew Calderaro	BOS Meeting 5/15/23		200.00	943,151.10
05/22/2023	1184	Robert Renn	BOS Meeting 5/15/23		200.00	942,951.10
05/22/2023	1185	Shelia Papelbon	BOS Meeting 5/15/23		200.00	942,751.10
05/22/2023	0522ACH1	Comcast	12750 Meritage Blvd. GATEHOUSE 4/30/23 - 5/29/23		216.11	942,534.99
05/23/2023	0523ACH1	Florida Natural Gas	Fuel and Inside FGT Z3 3/22/23 - 4/23/23		10.47	942,524.52
05/23/2023	ACH 052323	Credit Card transactions			2,865.90	939,658.62
05/24/2023	100211	Magnetix DJ Services	Invoice: 3514 (Reference: Trivia Night.)		350.00	939,308.62
05/25/2023	100212	10-S Tennis Supply & Dinkshot Pickleball	Invoice: 159439 (Reference: Tennis Net & Scarifler.)		347.45	938,961.17
05/25/2023	100213	Advanced Security Specialist & Consulting	Invoice: T0052023A (Reference: 05.01.23 TO 05.15.23 GUARD HOUSE GATE ACCESS MAN.		9,000.00	929,961.17
05/25/2023	100214	Integrated Access Solutions	Invoice: 0003115 (Reference: BAI Barcodes Black on Black.) Invoice: 0003117 (Reference: Cor		782.78	929,178.39
05/25/2023	100215	Vesta District Services	Invoice: 410165 (Reference: Additional Workshop Hours.) Invoice: 410183 (Reference: District		4,923.25	924,255.14
05/25/2023	100216	Lucas Tree Service, Inc.	Invoice: 8407 (Reference: Drop dead pine tree.)		500.00	923,755.14
05/25/2023	0525ACH1	Comcast	12788 Meritage Blvd. OFC 4 5/3/23 - 6/2/23		361.24	923,393.90
05/26/2023			Deposit	19,081.04		942,474.94

05/30/2023	0530ACH1	Comcast	13077 Beach Blvd. PEDESTRIAN GATE May 10, 2023 - June 09, 2023	199.35	942,275.59
05/31/2023	100217	Jacksonville Daily Record	Invoice: 052523- (Reference: Legal Advertising.)	96.50	942,179.09
05/31/2023	100218	Southeastern Paper Group	Invoice: 05909762 (Reference: Janitorial Supplies.)	375.12	941,803.97
05/31/2023	100219	TEKWave Solutions LLC	Invoice: 5753 (Reference: VMS - JUNE.)	295.00	941,508.97
05/31/2023			Service Charge	2.60	941,506.37
05/31/2023		EOM Balance		38,529.34	98,570.93
06/01/2023	100220	First Coast Fun and Games	Invoice: 5430 (Reference: Lazer Tag.)	600.00	940,906.37
06/06/2023	100221	Integrated Access Solutions	Invoice: 0003176 (Reference: BAI Barcodes Black on Black.)	383.78	940,522.59
06/06/2023	100222	Kutak Rock LLP	Invoice: 3226004 (Reference: General Counsel.)	2,574.00	937,948.59
06/06/2023	100223	TEKWave Solutions LLC	Invoice: 5750 (Reference: Remote Device Set Up.)	200.00	937,748.59
06/06/2023	100224	Lucas Tree Service, Inc.	Invoice: 8470 (Reference: Drop 4 dead trees.)	1,000.00	936,748.59
06/07/2023			Deposit	3,754.82	940,503.41
06/08/2023	100225	The Lake Doctors, Inc.	Invoice: 720157 (Reference: Water Management - Zone 1,Water Management - Zone 2.)	1,767.00	938,736.41
06/08/2023	100226	VGlobal Tech	Invoice: 5102 (Reference: Monthly email hosting.)	50.00	938,686.41
06/08/2023	0608ACH1	GFL Environmental	Trash Service	195.31	938,491.10
06/12/2023	100227	Jacksonville Daily Record	Invoice: 060823- (Reference: Legal Advertising.)	96.50	938,394.60
06/12/2023	100228	Turner Pest Control	Invoice: 617256835 (Reference: Pest Control.)	115.21	938,279.39
06/12/2023	100229	Vesta Property Services	Invoice: 410821 (Reference: Billable Expenses.)	2,093.40	936,185.99
06/12/2023	100230	B.A.B Tennis Courts	Invoice: 2 (Reference: Final Draw Tennis Center Resurfacing Project.)	5,950.00	930,235.99
06/13/2023	0613ACH1	JEA	Service for the month of May	27,905.24	902,330.75
06/14/2023			Deposit	192.36	902,523.11
06/15/2023	1186	Turner Pest Control	Pest Control	115.21	902,407.90
06/15/2023	100231	Sun State Nursery & Landscaping, Inc	Invoice: 10176 (Reference: May Landscape Maintenance.)	35,213.10	867,194.80
06/15/2023	100232	Vesta Property Services	Invoice: 410762 (Reference: Amenity Management.)	23,020.64	844,174.16
06/15/2023	100233	Vesta District Services	Invoice: 410771 (Reference: Billable Expenses - May 2023.)	149.50	844,024.66
06/15/2023			Deposit	10,319.55	854,344.21
06/20/2023	100234	Advanced Security Specialist & Consulting	Invoice: T0062023A (Reference: 06.01.23 TO 06.15.23.)	9,000.00	845,344.21
06/20/2023	100235	TEKWave Solutions LLC	Invoice: 5776 (Reference: Vehicle Passes.)	935.00	844,409.21
06/20/2023	100236	Poker Face Comedy, LLC	Invoice: 000014 (Reference: Comedian for Father's Day Brunch.)	650.00	843,759.21
06/20/2023	0620ACH1	Comcast	12750 Meritage Blvd. GATEHOUSE 5/30/23 - 6/29/23	216.11	843,543.10
06/20/2023	0620ACH2	Comcast	12788 Meritace Blvd MINI MDTA 5/28/23 - 6/27/23	546.50	842,996.60
06/20/2023	0620ACH3	TECO	12545 Beach Blvd - 4/22/23 - 5/23/23	36.91	842,959.69
06/22/2023	01ACH062223	Florida Natural Gas	Fuel and Inside FGT Z3 4/21/23-5/23/23	10.67	842,949.02
06/23/2023	100237	Advanced Security Specialist & Consulting	Invoice: T0052023B (Reference: 05.16.23 TO 05.31.23.) Invoice: T0052023 (Reference: 5/1/23	12,682.50	830,266.52
06/23/2023	100238	Southeastern Paper Group	Invoice: 05928476 (Reference: Janitorial Supplies.)	359.87	829,906.65
06/23/2023	100239	Wayne Automatic Fire Sprinklers Inc.	Invoice: 1054267 (Reference: Quarterly Sprinkler Inspection.)	75.00	829,831.65
06/23/2023	100240	Vesta District Services	Invoice: 410895 (Reference: District Management Services.)	3,958.33	825,873.32
06/23/2023	100241	Wild Wonders	Invoice: 052423- (Reference: Scaly Sensations.)	300.00	825,573.32
06/23/2023	ACH 062323	Credit Card transactions		2,005.18	823,568.14
06/26/2023	0626ACH1	Comcast	12788 Meritage Blvd. OFC 4 6/3/23 - 7/2/23	359.30	823,208.84
06/28/2023	1189	Duval's Cleanest LLC	Pressure Washing Pillars & Entrance Sign	500.00	822,708.84
06/28/2023	1190	Magnetix DJ Services	MC/DJ Member Independence Pool Party	400.00	822,308.84
06/28/2023	1191	Screening One	Screening of Trainers	180.00	822,128.84
06/28/2023	1192	Tampa Print Services, Inc.	Printing Services	539.16	821,589.68
06/29/2023			Deposit	6,561.00	828,150.68
06/30/2023	0630ACH1	Comcast	13077 Beach Blvd. PEDESTRIAN GATE June 10, 2023 - July 9, 2023	199.35	827,951.33
06/30/2023			Service Charge	1.90	827,949.43
06/20/2023	100236	Poker Face Comedy, LLC	Invoice: 000014 (Reference: Comedian for Father's Day Brunch.)	Cancelled	-650.00
06/30/2023		EOM Balance		20,827.73	134,384.67
07/01/2023	1187	BNY Mellon Tax Distributions	Tax Distributions 2013A	118,057.53	710,541.90
07/01/2023	1188	BNY Mellon Tax Distributions	Tax Distributions 2015A	51,237.53	659,304.37
07/03/2023	68		Returned NSF check #319 dated 4/25/23 Wm Revels	200.00	659,104.37

07/03/2023	68		Returned NSF check #319 dated 4/25/23 Wm Revels - check fee		10.00	659,094.37
07/05/2023	100242	Jacksonville Daily Record	Invoice: 062223- (Reference: Legal Advertising.) Invoice: 062923- (Reference: Legal Advertisi..		625.00	658,469.37
07/05/2023	100243	Kutak Rock LLP	Invoice: 3239803 (Reference: General Counsel.)		2,985.50	655,483.87
07/05/2023	100244	Southeastern Paper Group	Invoice: 05935934 (Reference: Janitorial Supplies.)		457.84	655,026.03
07/05/2023	100245	TEKWave Solutions LLC	Invoice: 5804 (Reference: VMS - JULY.)		295.00	654,731.03
07/05/2023	100246	Vesta District Services	Invoice: 411076 (Reference: District Management Services.)		3,958.33	650,772.70
07/05/2023	100247	Ancient City Hardscapes, LLC	Invoice: 2020318 (Reference: Assorted Paver Repairs.)		475.00	650,297.70
07/05/2023	100248	Nathan Pokipala	Invoice: 1235 (Reference: 4th of July Entertainment.)		1,775.00	648,522.70
07/10/2023	100249	Southeastern Paper Group	Invoice: 05938316 (Reference: Supplies.)		179.92	648,342.78
07/10/2023	100250	Vesta Property Services	Invoice: 411576 (Reference: Amenity Services.)		32,532.91	615,809.87
07/10/2023	0710ACH1	GFL Environmental	Trash Service		178.03	615,631.84
07/12/2023	100251	Advanced Security Specialist & Consulting	Invoice: T0062023 (Reference: Security @ Tamaya 6/1 - 6/30/23.)		2,450.00	613,181.84
07/12/2023	100252	Sun State Nursery & Landscaping, Inc	Invoice: 10505 (Reference: June Landscape Maintenance.)		35,213.10	577,968.74
07/12/2023	100253	The Lake Doctors, Inc.	Invoice: 106688B (Reference: Water Management.)		1,767.00	576,201.74
07/12/2023	100254	VGlobal Tech	Invoice: 5218 (Reference: Email hosting.)		50.00	576,151.74
07/12/2023	100255	All Weather Contractors, Inc.	Invoice: 161697 (Reference: Plumbing Call Floor Drain Fitness Center.)		195.00	575,956.74
07/14/2023	100256	Advanced Security Specialist & Consulting	Invoice: T0062023B (Reference: 06.16.23 TO 06.30.23.)		9,300.00	566,656.74
07/14/2023	100257	Integrated Access Solutions	Invoice: 0003448 (Reference: Service Call.)		132.00	566,524.74
07/18/2023			Deposit	4,175.00		570,699.74
07/18/2023			Deposit	7,875.00		578,574.74
07/18/2023	0718ACH1	Comcast	12788 Meritace Blvd MINI MDTA 6/28/23 - 7/27/23		550.50	578,024.24
07/18/2023	0718ACH2	JEA	Service for the month of June		30,205.87	547,818.37
07/19/2023	1193	Maximum Entertainment Trivia	Monthly Trivia July 20th		200.00	547,618.37
07/19/2023	0719ACH1	TECO	12545 Beach Blvd - 5/24/23 - 6/22/23		36.35	547,582.02
07/19/2023			Account Closing Transfer	100.00		547,682.02
07/20/2023	0720ACH1	Comcast	12750 Meritage Blvd. GATEHOUSE 6/30/23 - 7/29/23		217.11	547,464.91
07/24/2023	0724ACH1	Florida Natural Gas	Fuel and Inside FGT Z3 5/23/23 - 6/22/23		10.28	547,454.63
07/24/2023	0724CC1	Credit Card transactions			2,464.79	544,989.84
07/25/2023			Deposit	192.36		545,182.20
07/25/2023	0725ACH1	Comcast	12788 Meritage Blvd. OFC 4 Jul 03, 2023 to Aug 02, 2023		359.30	544,822.90
07/26/2023	1194	Frederick Marshall Moore	Refund of Reservation		700.00	544,122.90
07/26/2023	1195	Chance Wedderburn	BOS Meeting 7/17/23		200.00	543,922.90
07/26/2023	1196	Elena Korsakova	BOS Meeting 7/17/23		200.00	543,722.90
07/26/2023	1197	Matthew Calderaro	BOS Meeting 7/17/23		200.00	543,522.90
07/26/2023	1198	Robert Renn	BOS Meeting 7/17/23		200.00	543,322.90
07/26/2023	1199	Shelia Papelbon	BOS Meeting 7/17/23		200.00	543,122.90
07/26/2023	100258	Advanced Security Specialist & Consulting	Invoice: T0072023A (Reference: 07.01.23 TO 07.15.23.)		9,300.00	533,822.90
07/26/2023	100259	Custom Pump & Controls, Inc.	Invoice: 51318 (Reference: COJ OWNERS SIGN.) Invoice: 23-314-03 (Reference: QUARTERI		445.63	533,377.27
07/26/2023	100260	Integrated Access Solutions	Invoice: 0003505 (Reference: BAI Barcodes Black on Black.)		383.78	532,993.49
07/26/2023	100261	Southeastern Paper Group	Invoice: 05946343 (Reference: Supplies.)		398.05	532,595.44
07/26/2023	100262	TEKWave Solutions LLC	Invoice: 5848 (Reference: VMS - August.)		295.00	532,300.44
07/31/2023	0731ACH1	Comcast	13077 Beach Blvd. PEDESTRIAN GATE July 10, 2023 - Aug 9, 2023		199.35	532,101.09
07/31/2023			Service Charge		1.60	532,099.49
7/31/2023		EOM Balance			12,342.36	308,842.30
08/01/2023	100263	Vesta District Services	Invoice: 411747 (Reference: District Management Services.)		3,958.33	528,141.16
08/02/2023			Deposit	54,231.04		582,372.20
08/03/2023			Deposit	2,680.00		585,052.20
08/04/2023	100264	Southeast Fitness	Invoice: 102279 (Reference: Diagnosis of Rear Delt Machine.)		179.83	584,872.37
08/04/2023	100265	Southeastern Paper Group	Invoice: 05953385 (Reference: Janitorial Supplies.)		243.07	584,629.30
08/04/2023	100266	The Lake Doctors, Inc.	Invoice: 113881B (Reference: Water Management.)		1,767.00	582,862.30
08/04/2023	100267	VGlobal Tech	Invoice: 5292 (Reference: Email hosting.)		50.00	582,812.30
08/07/2023	100268	Advanced Security Specialist & Consulting	Invoice: T0072023B (Reference: 07.16.23 TO 07.31.23 guard service.) Invoice: T0072023 (Refi		11,805.00	571,007.30

08/09/2023	100269	Jacksonville Daily Record	Invoice: 080323- (Reference: Board of Supervisors Meeting.)	110.00	570,897.30
08/09/2023	100270	Kutak Rock LLP	Invoice: 3264063 (Reference: General Legal Matters.)	365.00	570,532.30
08/09/2023	100271	Magnetix DJ Services	Invoice: 3520 (Reference: Outdoor Teen Foam Party.)	275.00	570,257.30
08/09/2023	100272	Leisure Creations	Invoice: 00078396 (Reference: Replacement Seat Sling.)	499.52	569,757.78
08/09/2023	100273	Dibartolomeo, McBee, Hartley & Barnes, PA	Invoice: 90093309 (Reference: CPA Services FYE 09.30.22.)	3,250.00	566,507.78
08/09/2023	100274	The Jacksonville Party Company	Invoice: 07292023.07 (Reference: "Welcome to Vegas" Party.)	3,002.10	563,505.68
08/09/2023	0809ACH1	GFL Environmental	Trash Service	178.03	563,327.65
08/11/2023			Deposit	192.36	563,520.01
08/14/2023	100275	Jacksonville Daily Record	Invoice: 081023- (Reference: Legal Advertising.)	99.88	563,420.13
08/14/2023	100276	Vesta Property Services	Invoice: 412318 (Reference: Amenity Management.) Invoice: 412392 (Reference: Billable Expe	41,435.59	521,984.54
08/14/2023	100277	Maximum Entertainment	Invoice: 2 (Reference: Trivia 8.18.23.)	200.00	521,784.54
08/15/2023	100278	Big Z Pool Service, LLC	Invoice: 12679 (Reference: Black Algae Scrub.)	1,780.00	520,004.54
08/15/2023	100279	Integrated Access Solutions	Invoice: 0003605 (Reference: Move Antenna.) Invoice: 0003606 (Reference: 5 Port PoE switch	532.98	519,471.56
08/15/2023	100280	Vesta District Services	Invoice: 411642 (Reference: Billable Expenses - June 2023.)	11.40	519,460.16
08/15/2023	100281	Lucas Tree Service, Inc.	Invoice: 8867 (Reference: Drop 4 dead pine trees.)	1,000.00	518,460.16
08/16/2023	100282	Bouncers, Slides, and More Inc.	Invoice: 08112023.11 (Reference: Bounce House & Obstacle Course.)	500.00	517,960.16
08/16/2023	0816ACH1	JEA	Service for the month of July	28,065.77	489,894.39
08/17/2023	1201	KS State Bank	3361927	1,539.95	488,354.44
08/17/2023	1202	KS State Bank	3361927	1,539.95	486,814.49
08/18/2023	100283	Southeastern Paper Group	Invoice: 05967335 (Reference: Paper Supplies.)	468.19	486,346.30
08/18/2023	100284	First Coast Foam Party LLC	Invoice: 2023-08-11-03 (Reference: Glow party 8/11/23.)	1,050.00	485,296.30
08/18/2023	0818ACH1	TECO	12545 Beach Blvd - 6/23/23 - 7/20/23	36.35	485,259.95
08/18/2023	018ACH1	Comcast	12788 Meritace Blvd MINI MDTA 7/28/23 - 8/27/23	544.45	484,715.50
08/21/2023			Deposit	3,787.00	488,502.50
08/21/2023	0821ACH1	Comcast	12750 Meritage Blvd. GATEHOUSE Jul 30, 2023 to Aug 29, 2023	215.92	488,286.58
08/22/2023	0822ACH1	Florida Natural Gas	Fuel and Inside FGT Z3 6/22/23 - 7/20/23	10.79	488,275.79
08/23/2023	1203	Magnetix DJ Services	Outdoor Carnival	400.00	487,875.79
08/23/2023	ACH 082323	Credit Card transactions		2,817.25	485,058.54
08/23/2023	69		Resident bounced check	700.00	484,358.54
08/23/2023	69		Resident bounced check fee	10.00	484,348.54
08/24/2023	100285	Advanced Security Specialist & Consulting	Invoice: T0082023A (Reference: 08.01.23 TO 08.15.23.)	9,000.00	475,348.54
08/24/2023	100286	Big Z Pool Service, LLC	Invoice: 12680 (Reference: Black Algae Scrub family pool.)	1,980.00	473,368.54
08/24/2023	100287	Integrated Access Solutions	Invoice: 0003711 (Reference: Service Call Entry Arm.)	188.43	473,180.11
08/24/2023	100288	All Weather Contractors, Inc.	Invoice: 165174 (Reference: Installed Faucet & adjusted flush valves.) Invoice: 165333 (Refer...	2,461.25	470,718.86
08/25/2023	1200	Gabriele M. Beyer	Refund from Lost Keycard found	25.00	470,693.86
08/25/2023	1204	Duval's Cleanest LLC	Pressure Washing Pillars at old Beach Blvd entrance	600.00	470,093.86
08/25/2023	825ACH1	Comcast	12788 Meritage Blvd. OFC 4 Aug 03, 2023 to Sep 02, 2023	359.30	469,734.56
08/28/2023	1205	Elena Korsakova	BOS Meeting 8/21/23	200.00	469,534.56
08/28/2023	1206	Matthew Calderaro	BOS Meeting 8/21/23	200.00	469,334.56
08/28/2023	1207	Robert Renn	BOS Meeting 8/21/23	200.00	469,134.56
08/29/2023			Deposit	1,000.00	470,134.56
08/29/2023	100289	Buehler Air Conditioning	Invoice: 114952 (Reference: Commercial Diagnostic.)	129.00	470,005.56
08/29/2023	100290	TEKWave Solutions LLC	Invoice: 5932 (Reference: VMS - SEPT.)	295.00	469,710.56
08/30/2023	0830ACH1	Comcast	13077 Beach Blvd. PEDESTRIAN GATE Aug 10, 2023 to Sep 09, 2023	199.35	469,511.21
08/31/2023			Deposit	1,980.08	471,491.29
08/31/2023			Service Charge	2.40	471,488.89
8/31/2023		EOM Balance		63,870.48	124,481.08
					471,488.89

EXHIBIT 10

Beach
Community Development District

Financial Statements
(Unaudited)

Preliminary

November 30, 2023

Beach CDD
Balance Sheet
November 30, 2023

	General Fund	Reserve Fund	Debt Service 2013A	Debt Service 2015A	Total
1 ASSETS					
2 OPERATING ACCOUNT BU	\$ 2,340,657	\$ -	\$ -	\$ -	\$ 2,340,657
3 CHECKING ACCOUNT CS	49,246	-	-	-	49,246
4 DEBT CARD ACCOUNT CS	893	-	-	-	893
5 DEBT SERVICE ACCOUNTS:					
6 SINKING FUND	-	-	-	-	-
7 INTEREST FUND	-	-	-	-	-
8 REDEMPTION FUND	-	-	37	150	187
9 PREPAYMENT FUND	-	-	942	33,048	33,990
10 REVENUE FUND	-	-	143,981	6,308	150,289
11 OP REDEMPTION FUND	-	-	-	-	-
12 ACQ & CONS	-	-	-	-	-
13 ACCOUNTS RECEIVABLE	500	-	-	-	500
14 ASSESSMENTS RECEIVABLE ON-ROLL	346,933	17,733	161,505	74,563	600,734
15 ASSESSMENTS RECEIVABLE OFF-ROLL	256,709	13,122	-	234,228	504,059
16 DUE FROM OTHER FUNDS	20,956	69,145	629,726	290,729	1,010,556
17 PREPAID	3,966	-	-	-	3,966
18 TOTAL ASSETS	\$ 3,019,861	\$ 100,000	\$ 936,191	\$ 639,025	\$ 4,695,077
19 LIABILITIES					
20 ACCOUNTS PAYABLE	\$ 82,483	\$ -	\$ -	\$ -	\$ 82,483
21 DEFERRED REVENUE ON-ROLL	346,933	17,733	161,505	74,563	600,734
22 DEFERRED REVENUE OFF-ROLL	256,709	13,122	-	234,228	504,059
23 DUE TO OTHER FUNDS	989,599	20,956	-	-	1,010,556
24 TOTAL LIABILITIES	1,675,725	51,811	161,505	308,791	2,197,833
25 FUND BALANCE					
26 NONSPENDABLE					
27 PREPAID & DEPOSITS	3,966	-	-	-	3,966
28 CAPITAL RESERVES	109,319	-	-	-	109,319
29 OPERATING CAPITAL	-	-	-	-	-
30 UNASSIGNED	1,230,851	48,189	774,686	330,234	2,383,960
31 TOTAL FUND BALANCE	1,344,136	48,189	774,686	330,234	2,497,245
32 TOTAL LIABILITIES & FUND BALANCE	\$ 3,019,861	\$ 100,000	\$ 936,191	\$ 639,025	\$ 4,695,077

Beach CDD
General Fund
Statement of Revenue, Expenditures, and Changes in Fund Balance
For the period from October 1, 2023 to November 30, 2023

	FY 2024 Adopted Budget	FY 2024 Month of November	FY 2024 Total Actual Year-to-Date	VARIANCE Over (Under) to Budget	% Actual YTD / FY Budget
1 REVENUE					
2 ASSESSMENTS ON-ROLL	\$ 1,699,665	\$ 1,352,731	\$ 1,352,731	\$ (346,933)	80%
3 ASSESSMENTS OFF-ROLL	256,709	-	67,458	(189,252)	26%
4 INTEREST REVENUE	-	3	7	7	
5 OTHER FINANCING SOURCES	-	424	3,531	3,531	
6 TOTAL REVENUE	\$ 1,956,374	\$ 1,353,158	\$ 1,423,727	\$ (532,647)	73%
7 EXPENDITURES					
8 GENERAL & ADMINISTRATIVE EXPENSES					
9 TRUSTEE FEES	\$ 9,500	\$ 8,800	\$ 8,800	\$ (700)	93%
10 SUPERVISOR FEES-REGULAR MEETINGS	12,000	800	1,800	(10,200)	15%
11 SUPERVISOR FEES-WORKSHOPS	2,000	-	600	(1,400)	30%
12 DISTRICT MANAGEMENT	43,680	4,117	8,233	(35,447)	19%
13 ENGINEERING	5,000	-	-	(5,000)	0%
14 DISSEMINATION AGENT	2,600	-	2,600	-	100%
15 DISTRICT COUNSEL	18,000	-	4,406	(13,594)	24%
16 ASSESSMENT ADMINISTRATION	5,720	-	-	(5,720)	0%
17 ARBITRAGE REBATE CALCULATION	3,300	-	-	(3,300)	0%
18 AUDIT	3,450	-	-	(3,450)	0%
19 WEBSITE	2,150	191	1,898	(253)	88%
20 LEGAL ADVERTISING	7,000	97	286	(6,714)	4%
21 DUES, LICENSES & FEES	175	-	175	-	100%
22 GENERAL LIABILITY INSURANCE	129,560	-	72,332	(57,228)	56%
23 OFFICE MISCELLANEOUS	3,500	62	590	(2,910)	17%
24 DISTRICT CONTINGENCY	150,000	-	-	(150,000)	0%
25 TOTAL GENERAL & ADMINISTRATIVE EXPENSES	397,635	14,066	101,720	(295,915)	26%
26 FIELD EXPENSES					
27 FIELD MANAGEMENT	139,333	9,716	20,128	(119,205)	14%
28 LAKE MAINTENANCE	23,500	1,736	3,503	(19,997)	15%
29 LANDSCAPING (INCLUDING MATERIALS)	389,046	31,285	63,069	(325,977)	16%
30 MULCH AND PINE STRAW	32,000	-	-	(32,000)	0%
31 IRRIGATION (REPAIRS)	4,000	-	-	(4,000)	0%
32 UTILITIES/SEWERS/PROPANE GAS	291,000	20,347	40,646	(250,354)	14%
33 CONTINGENCY - HURRICANE / STORM CLEAN UP	8,000	-	-	(8,000)	0%
34 COMMUNITY MAINTENANCE	8,000	-	2,659	(5,341)	33%
35 TOTAL FIELD EXPENSES	894,879	63,084	130,006	(764,873)	15%

36	AMENITY EXPENSES					
37	AMENITY MANAGEMENT	128,551	12,661	23,809	(104,742)	19%
38	LIFEGUARD	23,305	-	-	(23,305)	0%
39	AMENITY/FITNESS CENTER STAFFING	73,000	3,399	6,791	(66,209)	9%
40	SWIMMING POOL CHEMICALS	28,600	1,057	2,092	(26,508)	7%
41	POOL/ENTRY WATER FEATURE MAINTENANCE	25,529	-	-	(25,529)	0%
42	SWIMMING POOL INSPECTION	850	-	-	(850)	0%
43	AMENITY GENERAL MAINTENANCE & REPAIRS	21,000	1,847	3,394	(17,606)	16%
44	HOLIDAY DECORATIONS	10,000	-	-	(10,000)	0%
45	AMENITY CLEANING	24,000	1,796	3,184	(20,816)	13%
46	AMENITY GATES/CONTROL ACCESS	12,000	763	1,382	(10,618)	12%
47	AMENITY GATE REPAIRS	4,000	959	1,285	(2,715)	32%
48	AMENITY WEBSITE/COMPUTER EQUIPMENT	1,700	120	120	(1,580)	7%
49	AMENITY INTERNET/CABLE	15,000	1,004	2,268	(12,732)	15%
50	FITNESS EQUIPMENT LEASE	16,000	-	-	(16,000)	0%
51	LIFESTYLES PROGRAMMING	33,000	5,250	5,664	(27,336)	17%
52	TENNIS COURT MAINTENANCE - 4 CLAY COURTS	2,500	-	-	(2,500)	0%
53	LANDSCAPE IMPROVEMENT	2,500	-	1,499	(1,001)	60%
54	PEST CONTROL	1,600	115	230	(1,370)	14%
55	AMENITY FIRE SYSTEM MONITORING	1,425	-	-	(1,425)	0%
56	TRASH COLLECTION	2,300	195	391	(1,909)	17%
57	TOTAL AMENITY EXPENSES	426,860	29,167	52,109	(374,751)	12%
58	ACCESS CONTROL /GATE HOUSE					
59	GUARD SERVICE	232,000	21,420	41,940	(190,060)	18%
60	BAR CODE EXPENSE	5,000	-	384	(4,616)	8%
61	TOTAL ACCESS CONTROL/GATE HOUSE EXPENSES	237,000	21,420	42,324	(194,676)	18%
62	TOTAL EXPENDITURES	1,956,374	127,737	326,159	(1,630,215)	17%
63	EXCESS OF REVENUE OVER (UNDER) EXPENDITURES	-	1,225,421	1,097,568	1,097,568	
64	OTHER FINANCING SOURCES & USES					
65	TRANSFER IN	-	-	-	-	
66	TRANSFER OUT	-	-	-	-	
67	TOTAL OTHER FINANCING SOURCES & USES	-	-	-	-	
68	FUND BALANCE - BEGINNING	238,292		246,568	8,276	
69	NET CHANGE IN FUND BALANCE	-	1,225,421	1,097,568	1,097,568	
70	FUND BALANCE - ENDING	\$ 238,292		\$ 1,344,136	\$ 1,105,844	
71	ANALYSIS OF FUND BALANCE					
72	NONSPENDABLE					
73	PREPAID & DEPOSITS	886		3,966		
74	CAPITAL RESERVES	109,319		109,319		
75	OPERATING CAPITAL	-		-		
76	UNASSIGNED	128,087		1,230,851		
77	TOTAL FUND BALANCE	\$ 238,292		\$ 1,344,136		

Beach CDD
Capital Reserve Fund (CRF)
Statement of Revenue, Expenditures, and Changes in Fund Balance
For the period from October 1, 2023 to November 30, 2023

	FY 2024 Amended Budget	FY 2024 Total Actual Year-to-Date	VARIANCE Over (Under) to Budget
1 REVENUE			
2 ASSESSMENTS ON-ROLL	\$ 86,878	\$ 69,145	\$ (17,733)
3 ASSESSMENTS OFF-ROLL	13,122	-	(13,122)
4 INTEREST & MISCELLANEOUS	-	-	-
5 TOTAL REVENUE	100,000	69,145	(30,855)
6 EXPENDITURES			
7 CAPITAL IMPROVEMENT PLAN (CIP)	-	9,325	9,325
8 CONTINGENCY	-	11,632	11,632
9 TOTAL EXPENDITURES	-	20,956	20,956
10 EXCESS OF REVENUE OVER (UNDER) EXPENDITURES	100,000	48,189	(51,811)
11 OTHER FINANCING SOURCES & USES			
12 TRANSFERS IN	-		
13 TRANSFERS OUT	-	-	
14 TOTAL OTHER FINANCING SOURCES & USES	-	-	-
15 FUND BALANCE - BEGINNING	-		-
16 NET CHANGE IN FUND BALANCE	100,000	48,189	(51,811)
17 FUND BALANCE - ENDING	\$ 100,000	\$ 48,189	\$ (51,811)
18 ANALYSIS OF FUND BALANCE			
19 ASSIGNED			
20 FUTURE CAPITAL IMPROVEMENTS			
21 WORKING CAPITAL			
22 UNASSIGNED	100,000	48,189	
23 FUND BALANCE - ENDING	\$ 100,000	\$ 48,189	

Beach CDD
Debt Service 2013A
Statement of Revenue, Expenditures, and Changes in Fund Balance
For the period from October 1, 2023 to November 30, 2023

	FY 2024 Adopted Budget	FY 2024 Actual Year-to-Date	VARIANCE Over (Under) to Budget
1 REVENUE			
2 ASSESSMENTS ON-ROLL	\$ 795,300	\$ 629,726	\$ (165,574)
3 ASSESSMENTS OFF-ROLL	-	-	-
4 INTEREST REVENUE	-	2,999	2,999
5 MISC. REVENUE	-	-	-
6 TOTAL REVENUE	795,300	632,725	(162,575)
7 EXPENDITURES			
8 INTEREST EXPENSE			
9 November 1, 2023	-	305,035	305,035
10 May 1, 2024	305,575	-	(305,575)
11 November 1, 2024	299,378	-	(299,378)
12 PRINCIPAL RETIREMENT			
13 May 1, 2024	185,000	-	(185,000)
14 PRINCIPAL PREPAYMENT	-	65,000	65,000
15 TOTAL EXPENDITURES	789,953	370,035	419,918
16 EXCESS OF REVENUE OVER (UNDER) EXPENDITURES	5,348	262,690	257,342
17 OTHER FINANCING SOURCES (USES)			
18 TRANSFER IN	-	-	-
19 TRANSFER OUT (USES)	-	-	-
20 TOTAL OTHER FINANCING SOURCES (USES)	-	-	-
21 FUND BALANCE - BEGINNING	511,997	511,997	-
22 NET CHANGE IN FUND BALANCE	5,348	262,690	257,342
23 FUND BALANCE - ENDING	\$ 517,344	\$ 774,686	\$ 257,342

Beach CDD
Debt Service 2015A
Statement of Revenue, Expenditures, and Changes in Fund Balance
For the period from October 1, 2023 to November 30, 2023

	FY 2024 Adopted Budget	FY 2024 Actual Year-to-Date	VARIANCE Over (Under) to Budget
1 REVENUE			
2 ASSESSMENTS ON-ROLL	\$ 365,292	\$ 290,729	\$ (74,563)
3 ASSESSMENTS OFF-ROLL	234,228	-	(234,228)
4 INTEREST REVENUE	-	742	742
5 MISC. REVENUE	-	-	-
6 TOTAL REVENUE	599,520	291,470	(308,050)
7 EXPENDITURES			
8 INTEREST EXPENSE			
9 November 1, 2023	-	217,120	217,120
10 May 1, 2024	217,268	-	(217,268)
11 November 1, 2024	212,253	-	(212,253)
12 PRINCIPAL RETIREMENT			
13 May 1, 2024	170,000	-	(170,000)
14 PRINCIPAL PREPAYMENT	-	80,000	80,000
15 TOTAL EXPENDITURES	599,520	297,120	302,400
16 EXCESS OF REVENUE OVER (UNDER) EXPENDITURES	-	(5,650)	(5,650)
17 OTHER FINANCING SOURCES (USES)			
18 TRANSFER IN	-	-	-
19 TRANSFER OUT (USES)	-	-	-
20 TOTAL OTHER FINANCING SOURCES (USES)	-	-	-
21 FUND BALANCE - BEGINNING	335,883	335,883	-
22 NET CHANGE IN FUND BALANCE	-	(5,650)	(5,650)
23 FUND BALANCE - ENDING	\$ 335,883	\$ 330,234	\$ (5,650)

Beach CDD Check Register - FY2024

Date	Ref. Num	Name	Memo	Deposits	Disbursements	Balance
09/30/2023		BOY Balance				351,783.82
10/01/2023	1219	Egis Insurance and Risk Advisors	FY Insurance Policy # 100123192 10/01/23-10/01/24		72,332.00	279,451.82
10/02/2023	1002ACH1	Comcast	13077 Beach Blvd. PEDESTRIAN GATE Sep 10, 2023 to Oct 09, 2023		199.35	279,252.47
10/03/2023	100319	Advanced Security Specialist & Consulting	Invoice: T0092023B (Reference: 09.16.23 TO 09.30.23 Security.) Invoice: T0092023 (Referenc		11,520.00	267,732.47
10/03/2023	100320	Innersync	Invoice: 21751 (Reference: Website Services.)		1,515.00	266,217.47
10/03/2023	100321	The Lake Doctors, Inc.	Invoice: 128865B (Reference: Water Management Zone 1 & 2.)		1,767.00	264,450.47
10/03/2023	100322	Vesta District Services	Invoice: 413498 (Reference: District Management Services.) Invoice: 413499 (Reference: Annu:		6,716.67	257,733.80
10/04/2023	100323	VGlobal Tech	Invoice: 5502 (Reference: Email hosting.)		50.00	257,683.80
10/06/2023	1220	Turner Pest Control			345.63	257,338.17
10/11/2023	1011ACH1	GFL Environmental	Trash Service		195.31	257,142.86
10/12/2023	100324	Jacksonville Daily Record	Invoice: 23-06605D (Reference: Legal Advertising.)		96.50	257,046.36
10/12/2023	100325	Kutak Rock LLP	Invoice: 3292492 (Reference: Legal services for August.)		1,975.00	255,071.36
10/17/2023			Deposit	192.36		255,263.72
10/17/2023			Deposit	2,200.00		257,463.72
10/17/2023	100326	Buehler Air Conditioning	Invoice: 117878 (Reference: Leak Check.) Invoice: 117745 (Reference: - Commercial Diagnosti		921.00	256,542.72
10/17/2023	100327	Custom Pump & Controls, Inc.	Invoice: 23-314-04 (Reference: QUARTERLY LIFT STATION INSPECTION.)		150.00	256,392.72
10/17/2023	100328	Integrated Access Solutions	Invoice: 0004071 (Reference: BAI Barcodes Black on Black.)		383.78	256,008.94
10/17/2023	100329	Jacksonville Daily Record	Invoice: 23-06781D (Reference: Legal Advertising.)		93.13	255,915.81
10/17/2023	100330	Southeastern Paper Group	Invoice: 06009873 (Reference: Janitorial Supplies.)		437.00	255,478.81
10/17/2023	100331	Lucas Tree Service, Inc.	Invoice: 9150 (Reference: Remove Pine Trees.)		1,000.00	254,478.81
10/17/2023	1017ACH1	JEA	Service for the month of September		22,662.66	231,816.15
10/17/2023	1117ACH1	TECO	12545 Beach Blvd - Sep 21, 2023 - Oct 20, 2023		36.30	231,779.85
10/18/2023	1018ACH1	Turner Pest Control	Pest Control		115.21	231,664.64
10/18/2023	1018ACH2	Comcast	12788 Meritace Blvd MINI MDTA Sep 28, 2023 to Oct 27, 2023		548.45	231,116.19
10/19/2023	100332	Advanced Security Specialist & Consulting	Invoice: T0102023A (Reference: October 1, 2023 - October 15, 2023 Guard Gate.)		9,000.00	222,116.19
10/19/2023	100333	Vesta District Services	Invoice: 414258 (Reference: Billable Expenses - Sep 2023.)		69.13	222,047.06
10/19/2023	100334	Jani-King of Jacksonville	Invoice: JAK10230486 (Reference: Commercial Cleaning.)		1,387.84	220,659.22
10/19/2023	1019ACH1	TECO	12545 Beach Blvd - 8/18/23 - 9/20/23		36.97	220,622.25
10/19/2023	1019ACH2	Turner Pest Control	Pest Control		115.21	220,507.04
10/20/2023	1020ACH1	Comcast	12750 Meritage Blvd. GATEHOUSE Sep 30, 2023 to Oct 29, 2023		238.20	220,268.84
10/23/2023	ACH102323	Florida Natural Gas	Fuel and Inside FGT Z3 8/18/23 - 9/20/23		11.37	220,257.47
10/23/2023	100335	Integrated Access Solutions	Invoice: 0004107 (Reference: Direct ALL-IN-ONE OEM replacement.) Invoice: 0004108 (Refer		6,490.28	213,767.19
10/23/2023	100336	Vesta District Services	Invoice: 414351 (Reference: Excess Meetings Held FY2023.)		1,600.00	212,167.19
10/23/2023	ACH 102323	Credit Card transactions			2,138.42	210,028.77
10/24/2023	1221	Chance Wedderburn	BOS Meeting 10/16/23		200.00	209,828.77
10/24/2023	1222	Elena Korsakova	BOS Meeting 10/16/23		200.00	209,628.77
10/24/2023	1223	Matthew Calderaro	BOS Meeting 10/16/23		200.00	209,428.77
10/24/2023	1224	Robert Renn	BOS Meeting 10/16/23		200.00	209,228.77
10/24/2023	1225	Shelia Papelbon	BOS Meeting 10/16/23		200.00	209,028.77
10/25/2023			Deposit	67,457.77		276,486.54
10/25/2023	ACH 102523	Comcast	12788 Meritage Blvd. OFC 4 Oct 03, 2023 to Nov 02, 2023		359.30	276,127.24
10/27/2023	100337	Buehler Air Conditioning	Invoice: #118622 (Reference: Carrier 5 Ton Heat Pump Condenser.)		6,271.00	269,856.24
10/27/2023	100338	Integrated Access Solutions	Invoice: 0004127 (Reference: Service Call.)		326.00	269,530.24
10/27/2023	100339	Beaches Electrical Service, Inc.	Invoice: 12671 (Reference: Service Call.)		299.95	269,230.29
10/30/2023	1226	Elena Korsakova	BOS Workshop 10/25/23		200.00	269,030.29
10/30/2023	1227	Robert Renn	BOS Workshop 10/25/23		200.00	268,830.29
10/30/2023	1228	Shelia Papelbon	BOS Workshop 10/25/23		200.00	268,630.29

10/30/2023	1030ACH1	Comcast	13077 Beach Blvd. PEDESTRIAN GATE Oct 10, 2023 to Nov 09, 2023	199.35	268,430.94
10/31/2023			Service Charge	2.60	268,428.34
10/31/2023	EOM Balance			69,850.13	153,205.61
11/02/2023	100340	TEKWave Solutions LLC	Invoice: 6052 (Reference: VMS - NOV.)	295.00	268,133.34
11/02/2023	100341	Jani-King of Jacksonville	Invoice: JAK11230385 (Reference: MONTHLY CONTRACT BILLING AMOUNT FOR NOVEM	1,796.02	266,337.32
11/06/2023	100342	Advanced Security Specialist & Consulting	Invoice: T0102023B (Reference: Guard House Gate Access Management.) Invoice: T0102023 (I	12,120.00	254,217.32
11/06/2023	100343	Kutak Rock LLP	Invoice: 3298072 (Reference: General Counsel.)	2,431.00	251,786.32
11/06/2023	100344	The Lake Doctors, Inc.	Invoice: 136050B (Reference: Water Management Zone 1 & 2.)	1,292.00	250,494.32
11/06/2023	100345	VGlobal Tech	Invoice: 5562 (Reference: Email hosting.)	50.00	250,444.32
11/06/2023	100346	5 Star Pressure Washing Inc.	Invoice: 7040 (Reference: Pressure Washing.)	1,050.00	249,394.32
11/06/2023			Deposit	40,230.12	289,624.44
11/08/2023	1108ACH1	GFL Environmental	Trash Service	195.31	289,429.13
11/10/2023	100347	Vesta Property Services	Invoice: 414255 (Reference: Amenity Services.)	31,826.77	257,602.36
11/10/2023	100348	Vesta District Services	Invoice: 414380 (Reference: District Management Services.)	4,116.67	253,485.69
11/13/2023	100349	Jacksonville Daily Record	Invoice: 110923- (Reference: Legal Advertising.)	96.50	253,389.19
11/13/2023	100350	Southeastern Paper Group	Invoice: 06027046 (Reference: Janitorial Supplies.)	264.50	253,124.69
11/14/2023	1229	FLORIDA DEPT OF ECONOMIC OPPORTUNIT	FY 2023/2024 Special District Fee Invoice/Update Form	175.00	252,949.69
11/15/2023			Deposit	125,328.70	378,278.39
11/15/2023	1115ACH1	Turner Pest Control	Pest Control	115.21	378,163.18
11/16/2023	100351	Vesta Property Services	Invoice: 415004 (Reference: Billable Expenses.) Invoice: 415068 (Reference: Billable Expenses.	5,696.96	372,466.22
11/16/2023	100352	Screening One	Invoice: SC100345262 (Reference: Employment Screening.)	40.00	372,426.22
11/16/2023	100353	Maximum Entertainment	Invoice: 4 (Reference: Trivia 11.17.23.)	200.00	372,226.22
11/16/2023	1116ACH1	JEA	Service for the month of October 2023	20,052.04	352,174.18
11/17/2023	1230	SS Live Entertainment, LLC	Live Entertainment 4.22.23	500.00	351,674.18
11/17/2023	100354	The Lake Doctors, Inc.	Invoice: 139156B (Reference: Water Management - Monthly.)	444.00	351,230.18
11/17/2023	100355	Vesta Property Services	Invoice: 414168 (Reference: Billable Expenses.)	2,282.23	348,947.95
11/20/2023	ACH112023	Florida Natural Gas	Fuel and Inside FGT Z3 9/20/23 - 10/20/23	10.65	348,937.30
11/20/2023			Deposit	192.36	349,129.66
11/20/2023	1231	Brenna & Christopher Morgan	Pool Cabana Deposit Refund 7.18.23	150.00	348,979.66
11/20/2023			Deposit	56.17	349,035.83
11/20/2023	1120ACH2	Comcast	12788 Meritace Blvd MINI MDTA 10/28/23 - 11/27/23	635.51	348,400.32
11/20/2023			Deposit	145,149.92	493,550.24
11/20/2023	ACH 112023	Comcast	12750 Meritage Blvd. GATEHOUSE 10/30/23 - 11/29/23	269.17	493,281.07
11/22/2023	1232	BNY Mellon Payment/Trustee Fees	Trustee Fees 2013A: November 01, 2023 to October 31, 2024	4,400.00	488,881.07
11/22/2023	1233	BNY Mellon Payment/Trustee Fees	Trustee Fees 2015A: November 01, 2023 to October 31, 2024	4,400.00	484,481.07
11/24/2023	ACH 112423	Credit Card transactions		2,123.92	482,357.15
11/27/2023	100356	Advanced Security Specialist & Consulting	Invoice: T0112023A (Reference: Guard House Access Management 11/1 - 11/10 & 11/12 - 11/15.	9,300.00	473,057.15
11/27/2023	100357	Integrated Access Solutions	Invoice: 0004285 (Reference: Barrier Gate Install.)	8,194.98	464,862.17
11/27/2023	100358	Southeast Fitness	Invoice: 103007 (Reference: Repairs to Fitness Equipment.)	775.60	464,086.57
11/27/2023	100359	TEKWave Solutions LLC	Invoice: 6106 (Reference: VMS - DEC.)	295.00	463,791.57
11/27/2023	100360	Vesta Property Services	Invoice: 415062 (Reference: Amenity Management.)	25,093.14	438,698.43
11/27/2023	100361	Beaches Electrical Service, Inc.	Invoice: 12777 (Reference: Add circuit at guard shack for new gate arms.)	468.00	438,230.43
11/27/2023	100362	Vesta District Services	Invoice: 414935 (Reference: Billable Expenses - Oct 2023.)	162.34	438,068.09
11/27/2023	100363	The Tree Amigos Outdoor Services, Inc.	Invoice: 201486 (Reference: Remove Guava Plants / Add Sod @ Basketball Courts.)	649.00	437,419.09
11/27/2023	1127ACH1	Comcast	12788 Meritage Blvd. OFC 11/3/23 - 12/2/23	359.30	437,059.79
11/28/2023	1235	The Tree Amigos Outdoor Services, Inc.		127,138.76	309,921.03
11/28/2023	1236	Chance Wedderburn	BOS Meeting 11/20/23	200.00	309,721.03
11/28/2023	1237	Elena Korsakova	BOS Meeting 11/20/23	200.00	309,521.03
11/28/2023	1238	Matthew Calderaro	BOS Meeting 11/20/23	200.00	309,321.03
11/28/2023	1239	Robert Renn	BOS Meeting 11/20/23	200.00	309,121.03
11/29/2023			Deposit	346,220.82	655,341.85
11/30/2023			Deposit	175.00	655,516.85

11/30/2023	1130ACH1	Comcast	13077 Beach Blvd. PEDESTRIAN GATE 11/10/23 - 12/9/23		199.35	655,317.50
11/30/2023			Deposit	1,685,401.16		2,340,718.66
11/30/2023			Service Charge		61.90	2,340,656.76
11/30/2023	EOM Balance			2,342,754.25	270,525.83	2,340,656.76



October 2023 Statement

Open Date: 09/27/2023 Closing Date: 10/26/2023

Account: 4798 5101 5585 7978



Visa® Community Card

Elan Financial Services
BUS 30 ELN

1-866-552-8855

16

BEACH CDD
RONALD ZASTROCKY (CPN 002322892)

New Balance	\$0.00
Minimum Payment Due	\$0.00
Payment Due Date	11/23/2023

Activity Summary

Previous Balance		\$0.00
Payments		\$0.00
Other Credits		\$0.00
Purchases	+	\$2,123.92
Balance Transfers		\$0.00
Advances		\$0.00
Other Debits		\$0.00
Fees Charged		\$0.00
Interest Charged		\$0.00
New Balance	=	\$0.00
Past Due		\$0.00
Minimum Payment Due		\$0.00
Credit Line		\$20,000.00
Available Credit		\$20,000.00
Days in Billing Period		30

Payment Options:



Mail payment coupon with a check



Pay online at myaccountaccess.com



Pay by phone 1-866-552-8855

This is not a bill, do not remit payment.

CPN 002322892



THIS IS NOT A BILL.

24-Hour Elan Financial Services: 1-866-552-8855

- to pay by phone
- to change your address

000009466 01 SP 000638584514826 S

BEACH CDD
RONALD ZASTROCKY
250 INTERNATIONAL PKWY # 208
LAKE MARY FL 32746-5062



This memo statement only reflects the current activity on your account. An invoice has been sent to the applicable central billing account for the company.

Thank you.

What To Do If You Think You Find A Mistake On Your Statement

If you think there is an error on your statement, please call us at the telephone number on the front of this statement, or write to us at: Elan Financial Services, P.O. Box 6335, Fargo, ND 58125-6335.

In your letter or call, give us the following information:

- ▶ Account information: Your name and account number.
 - ▶ Dollar amount: The dollar amount of the suspected error.
 - ▶ Description of Problem: If you think there is an error on your bill, describe what you believe is wrong and why you believe it is a mistake.
- You must contact us within 60 days after the error appeared on your statement. While we investigate whether or not there has been an error, the following are true:
- ▶ We cannot try to collect the amount in question, or report you as delinquent on that amount.
 - ▶ The charge in question may remain on your statement, and we may continue to charge you interest on that amount. But, if we determine that we made a mistake, you will not have to pay the amount in question or any interest or other fees related to that amount.
 - ▶ While you do not have to pay the amount in question, you are responsible for the remainder of your balance.
 - ▶ We can apply any unpaid amount against your credit limit.

Your Rights If You Are Dissatisfied With Your Credit Card Purchases

If you are dissatisfied with the goods or services that you have purchased with your credit card, and you have tried in good faith to correct the problem with the merchant, you may have the right not to pay the remaining amount due on the purchase.

To use this right, all of the following must be true:

1. The purchase must have been made in your home state or within 100 miles of your current mailing address, and the purchase price must have been more than \$50. (Note: Neither of these are necessary if your purchase was based on an advertisement we mailed to you, or if we own the company that sold you the goods or services.)
2. You must have used your credit card for the purchase. Purchases made with cash advances from an ATM or with a check that accesses your credit card account do not qualify.
3. You must not yet have fully paid for the purchase.

If all of the criteria above are met and you are still dissatisfied with the purchase, contact us in writing at: Elan Financial Services, P.O. Box 6335, Fargo, ND 58125-6335. While we investigate, the same rules apply to the disputed amount as discussed above. After we finish our investigation, we will tell you our decision. At that point, if we think you owe an amount and you do not pay we may report you as delinquent.

Important Information Regarding Your Account

1. INTEREST CHARGE: Method of Computing Balance Subject to Interest Rate: We calculate the periodic rate or interest portion of the **INTEREST CHARGE** by multiplying the applicable Daily Periodic Rate ("**DPR**") by the Average Daily Balance ("**ADB**") (including new transactions) of the Purchase, Advance and Balance Transfer categories subject to interest, and then adding together the resulting interest from each category. We determine the **ADB** separately for the Purchases, Advances and Balance Transfer categories. To get the **ADB** in each category, we add together the daily balances in those categories for the billing cycle and divide the result by the number of days in the billing cycle. We determine the daily balances each day by taking the beginning balance of those Account categories (including any billed but unpaid interest, fees, credit insurance and other charges), adding any new interest, fees, and charges, and subtracting any payments or credits applied against your Account balances that day. We add a Purchase, Advance or Balance Transfer to the appropriate balances for those categories on the later of the transaction date or the first day of the statement period. Billed but unpaid interest on Purchases, Advances and Balance Transfers is added to the appropriate balances for those categories each month on the statement date. Billed but unpaid Advance Transaction Fees are added to the Advance balance of your Account on the date they are charged to your Account. Any billed but unpaid fees on Purchases, credit insurance charges, and other charges are added to the Purchase balance of the Account on the date they are charged to the Account. Billed but unpaid fees on Balance Transfers are added to the Balance Transfer balance of the Account on the date they are charged to the Account. In other words, billed and unpaid interest, fees, and charges will be included in the **ADB** of your Account that accrues interest and will reduce the amount of credit available to you. To the extent credit insurance charges, overlimit fees, Annual Fees, and/or Travel Membership Fees may be applied to your Account, such charges and/or fees are not included in the **ADB** calculation for Purchases until the first day of the billing cycle following the date the credit insurance charges, overlimit fees, Annual Fees and/or Travel Membership Fees (as applicable) are charged to the Account. Prior statement balances subject to an interest-free period that have been paid on or before the payment due date in the current billing cycle are not included in the **ADB** calculation.

2. Payment Information: We will accept payment via check, money order, the internet (including mobile and online) or phone or previously established automatic payment transaction. You must pay us in U.S. Dollars. If you make a payment from a foreign financial institution, you will be charged and agree to pay any collection fees added in connection with that transaction. The date you mail a payment is different than the date we receive the payment. The payment date is the day we receive your check or money order at Elan Financial Services, P.O. Box 790408, St. Louis, MO 63179-0408 or the day we receive your internet or phone payment. All payments by check or money order accompanied by a payment coupon and received at this payment address will be credited to your Account on the day of receipt if received by 5:00 p.m. CT on any banking day. Payments sent without the payment coupon or to an incorrect address will be processed and credited to your Account within 5 banking days of receipt. Payments sent without a payment coupon or to an incorrect address may result in a delayed credit to your Account, additional **INTEREST CHARGES**, fees, and/or Account suspension. The deadline for on-time internet and phone payments varies, but generally must be made before 5:00 p.m. CT to 8 p.m. CT depending on what day and how the payment is made. Please contact Elan Financial Services for internet, phone, and mobile crediting times specific to your Account and your payment option. Banking days are all calendar days except Saturday, Sunday and federal holidays. Payments due on a Saturday, Sunday or federal holiday and received on those days will be credited on the day of receipt. There is no prepayment penalty if you pay your balance at any time prior to your payment due date.

3. Credit Reporting: We may report information on your Account to Credit Bureaus. Late payments, missed payments or other defaults on your Account may be reflected in your credit report.



BEACH CDD
RONALD ZASTROCKY (CPN 002322892)

Elan Financial Services 1-866-552-8855



Important Messages

Paying Interest: You have a 24 to 30 day interest-free period for Purchases provided you have paid your previous balance in full by the Payment Due Date shown on your monthly Account statement. In order to avoid additional INTEREST CHARGES on Purchases, you must pay your new balance in full by the Payment Due Date shown on the front of your monthly Account statement.

There is no interest-free period for transactions that post to the Account as Advances or Balance Transfers except as provided in any Offer Materials. Those transactions are subject to interest from the date they post to the Account until the date they are paid in full.

Transactions

Purchases and Other Debits

Post Date	Trans Date	Ref #	Transaction Description	Amount	Notation
10/02	09/29	0622	THE HOME DEPOT 6365 JACKSONVILLE FL	\$85.73	_____
10/04	10/03	9113	AMZN Mktp US*TE23F1O72 Amzn.com/bill WA	\$9.99	_____
10/04	10/03	2014	Amazon.com*T952Y5QI0 Amzn.com/bill WA	\$14.95	_____
10/04	10/03	8085	AMZN Mktp US*T90OF24E1 Amzn.com/bill WA	\$323.80	_____
10/04	10/03	1697	AMZN Mktp US*T90GE5H80 Amzn.com/bill WA	\$173.92	_____
10/10	10/06	1121	BJS FUEL #9108 JACKSONVILLE FL	\$26.07	_____
10/10	10/06	1048	PUBLIX #644 JACKSONVILLE FL	\$3.19	_____
10/10	10/06	1204	BJS WHOLESALE #0108 JACKSONVILLE FL	\$66.03	_____
10/10	10/08	2275	PUBLIX #644 JACKSONVILLE FL	\$54.45	_____
10/10	10/08	2358	BJS WHOLESALE #0108 JACKSONVILLE FL	\$40.79	_____
10/10	10/09	2305	BATTERY SOURCE # 34 JACKSONVILLE FL	\$69.99	_____
10/16	10/13	8027	THE UPS STORE 3547 904-8661939 FL	\$14.12	_____
10/16	10/14	5399	OFFICEMAX/DEPOT 6737 JACKSONVILLE FL	\$12.88	_____
10/16	10/14	9049	PUBLIX #644 JACKSONVILLE FL	\$173.38	_____
10/20	10/18	4606	THE HOME DEPOT #6365 JACKSONVILLE FL	\$50.27	_____
10/23	10/20	1248	THE HOME DEPOT #6365 JACKSONVILLE FL	\$14.22	_____
10/23	10/20	3756	THE HOME DEPOT #6365 JACKSONVILLE FL	\$6.98	_____
10/23	10/21	3001	AMAZON.COM*6V8S65E23 SEATTLE WA	\$28.78	_____
10/23	10/23	7643	AMZN MKTP US*5K3CT52L3 SEATTLE WA	\$143.47	_____
10/23	10/23	3176	AMZN MKTP US*TD9R20NV1 SEATTLE WA	\$64.99	_____
10/25	10/24	7445	AMZN Mktp US*229WI5X43 Amzn.com/bill WA	\$479.97	_____
10/26	10/24	6141	PINCH A PENNY - 146 JACKSONVILLE FL	\$265.95	_____
TOTAL THIS PERIOD				\$2,123.92	

2023 Totals Year-to-Date	
Total Fees Charged in 2023	\$0.00
Total Interest Charged in 2023	\$0.00

Company Approval *(This area for use by your company)*

Signature/Approval: _____

Accounting Code: _____

Interest Charge Calculation

Your Annual Percentage Rate (APR) is the annual interest rate on your account.

**APR for current and future transactions.

Balance Type	Balance By Type	Balance Subject to Interest Rate	Variable	Interest Charge	Annual Percentage Rate	Expires with Statement
**BALANCE TRANSFER	\$0.00	\$0.00		\$0.00	0.00%	
**PURCHASES	\$0.00	\$0.00		\$0.00	0.00%	
**ADVANCES	\$0.00	\$0.00		\$0.00	0.00%	

Contact Us

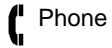

Phone

Voice: 1-866-552-8855
TDD: 1-888-352-6455
Fax: 1-866-807-9053



Questions

Elan Financial Services
P.O. Box 6353
Fargo, ND 58125-6353



Mail payment coupon
with a check

Elan Financial Services
P.O. Box 790408
St. Louis, MO 63179-0408



Online

myaccountaccess.com



How does
get more done.

12721 ATLANTIC BLVD
JACKSONVILLE, FL 32225 (904)2200822

6365 00051 96696 09/29/23 09:33 AM
SALE CASHIER BARBARA

736511500622 62SARGENTKEY <A>	
62 SARGENT	
4@3.97	15.88N
037504086759 MBRASSKEY <A>	
MINUTE KEY BRASS KEY	
2@3.97	7.94N
611942038190 PVC BUSHING <A>	
1-1/4"X1" PVC BUSHING SPGXS	
2@2.27	4.54N
611942038459 1-1/2 ADAPTR <A>	
1-1/2"X1-1/4" PVC MALE ADAPTER MPTXS	
2@5.47	10.94N
611942037612 1 PVC CPLG <A>	
1" PVC COUPLING SXS	
2@0.87	1.74N
039800068194 AA 36 PACK <A>	20.87N
ENERGIZER MAX AA 36-PACK	
012181159002 780 PVC - PU <A>	8.88N
780 PVC - PURP PRIMER TWIN PACK	
NLP Savings \$2.06	
027541001235 BOTTLE WATER <A>	
1/2 LITER WATER 24PK	
3@4.98	14.94N

SUBTOTAL 85.73
SALES TAX 0.00

TAX EXEMPT TOTAL \$85.73

XXXXXXXXXXXX7978 VISA USD\$ 85.73

AUTH CODE 809253/0518011 TA

Chip Read
AID A0000000031010 VISA CREDIT

PRO XTRA MEMBER STATEMENT

PRO XTRA ###-###-2277 SUMMARY
THIS RECEIPT PO/JOB NAME: TAMAYA

2023 PRO XTRA SPEND 09/28: \$1,522.41
INCLUDES:
2023 PROXTRA SAVINGS 09/28: \$10.09

As of 09/29/2023 your Paint Rewards level is Member; Spend 993.02 more in qualifying paint purchases to earn Bronze (10.0% off) on select paint items.

Get the CREDIT LINE your business needs PLUS earn Perks 4X FASTER when you join Pro Xtra, register, & use your Pro Xtra Credit Card. Apply and SAVE UP TO \$100. Learn more at homedepot.com/credit

6365 09/29/23 09:33 AM



6365 51 96696 09/29/2023 8337

RETURN POLICY DEFINITIONS
POLICY ID 1 DAYS 90 POLICY EXPIRES ON 12/28/2023

DID WE NAIL IT?
Take a short survey for a chance to WIN
A \$5,000 HOME DEPOT GIFT CARD

Opine en español
www.homedepot.com/survey

User ID: H89 200046 193732
PASSWORD: 23479 193681

Entries must be completed within 14 days of purchase. Entrants must be 18 or older to enter. See complete rules on website. No purchase necessary.



Final Details for Order #112-5973327-4151466

Order Placed: October 2, 2023
PO number : ron
Amazon.com order number: 112-5973327-4151466
Order Total: \$14.95

Business order information
Location: DSD - Tamaya GL code: 14000 Prepaid Expense Billable / Non-Billable: Non-Billable Cost center: Northeast

Shipped on October 3, 2023	
Items Ordered	Price
1 of: Goalrilla Ultra Heavy Duty All-Weather Nylon Net, White (B2602W) Sold by: Amazon.com Condition: New	\$14.95
Shipping Address: Ron Zastrocky 12788 MERITAGE BLVD JACKSONVILLE, FL 32246-0705 United States	Item(s) Subtotal: \$14.95 Shipping & Handling: \$0.00 ----- Total before tax: \$14.95 Sales Tax: \$0.00 -----
Shipping Speed: Standard Shipping	Total for This Shipment: \$14.95 -----

Payment information	
Payment Method: Visa Last digits: 7978	Item(s) Subtotal: \$14.95 Shipping & Handling: \$0.00 -----
Billing address Ron Zastrocky 12788 MERITAGE BLVD JACKSONVILLE, FL 32246-0705 United States	Total before tax: \$14.95 Estimated Tax: \$0.00 ----- Grand Total: \$14.95
Credit Card transactions	Visa ending in 7978: October 3, 2023: \$14.95

To view the status of your order, return to [Order Summary](#) .



Final Details for Order #112-3633392-8569832

Order Placed: October 3, 2023
PO number : ron
Amazon.com order number: 112-3633392-8569832
Order Total: \$9.99

Business order information
Location: DSD - Tamaya GL code: 14000 Prepaid Expense Billable / Non-Billable: Non-Billable Cost center: Northeast

Shipped on October 3, 2023	
Items Ordered	Price
1 of: Composite Shims for Indoor/Outdoor Use, 40 Pack Heavy Duty Never Rot Plastic Wedge Shims for Leveling, DIY Furniture Levelers for Home Improvement, Ta Sold by: JGKJ-US (seller profile) Condition: New	\$9.99
Shipping Address: Ron Zastrocky 12788 MERITAGE BLVD JACKSONVILLE, FL 32246-0705 United States	Item(s) Subtotal: \$9.99 Shipping & Handling: \$0.00 ----- Total before tax: \$9.99 Sales Tax: \$0.00 -----
Shipping Speed: FREE Prime Delivery	Total for This Shipment: \$9.99 -----

Payment information	
Payment Method: Visa Last digits: 7978	Item(s) Subtotal: \$9.99 Shipping & Handling: \$0.00 -----
Billing address Ron Zastrocky 12788 MERITAGE BLVD JACKSONVILLE, FL 32246-0705 United States	Total before tax: \$9.99 Estimated Tax: \$0.00 ----- Grand Total: \$9.99
Credit Card transactions	Visa ending in 7978: October 3, 2023: \$9.99

To view the status of your order, return to [Order Summary](#) .



Final Details for Order #112-1772003-2276224

Order Placed: October 3, 2023
PO number : ron
Amazon.com order number: 112-1772003-2276224
Order Total: \$323.80

Business order information
Location: DSD - Tamaya GL code: 14000 Prepaid Expense Billable / Non-Billable: Non-Billable Cost center: Northeast

Shipped on October 3, 2023	
Items Ordered	Price
1 of: KEYSKAN HID-C1325-50 HID Standard Proximity Card 36-bit Format (Pack of 50) Sold by: JMAC Supply (seller profile) Condition: New	\$323.80
Shipping Address: Ron Zastrocky 12788 MERITAGE BLVD JACKSONVILLE, FL 32246-0705 United States	Item(s) Subtotal: \$323.80 Shipping & Handling: \$0.00 ----- Total before tax: \$323.80 Sales Tax: \$0.00 -----
Shipping Speed: Standard Shipping	Total for This Shipment: \$323.80 -----

Payment information	
Payment Method: Visa Last digits: 7978	Item(s) Subtotal: \$323.80 Shipping & Handling: \$0.00 -----
Billing address Ron Zastrocky 12788 MERITAGE BLVD JACKSONVILLE, FL 32246-0705 United States	Total before tax: \$323.80 Estimated Tax: \$0.00 ----- Grand Total: \$323.80
Credit Card transactions	Visa ending in 7978: October 3, 2023: \$323.80

To view the status of your order, return to [Order Summary](#) .



Final Details for Order #112-8673255-8935461

Order Placed: October 2, 2023
PO number : ron
Amazon.com order number: 112-8673255-8935461
Order Total: \$173.92

Business order information
Location: DSD - Tamaya GL code: 14000 Prepaid Expense Billable / Non-Billable: Non-Billable Cost center: Northeast

Shipped on October 2, 2023	
Items Ordered	Price
1 Of: <i>Fresh Products Wave 3D, Virtually eliminates urine splash, 30-Day Use, Easy Installation, Beneficial Bacteria, Consistent Fragrance - Cotton Blossom,</i> Sold by: FP Trading Company (seller profile) Business Price Condition: New	\$25.87
5 Of: <i>Fresh Products Eco-Air Refill, Air Freshener, Dry Fragrance Refill, Natural Oils, No Acetone or Propellants, Lasts 30 Days, Eco-Friendly, Powerful Fra</i> Sold by: FP Trading Company (seller profile) Business Price Condition: New	\$27.63
1 Of: <i>12 X 8 Inch, No Dumping No Yard Waste No Littering, Warning Traffic Notice Road Safety Street Metal Tin Sign</i> Sold by: Jane Harvey (seller profile) Condition: New	\$9.90
Shipping Address: Ron Zastrocky 12788 MERITAGE BLVD JACKSONVILLE, FL 32246-0705 United States	Item(s) Subtotal: \$173.92 Shipping & Handling: \$0.00 ----- Total before tax: \$173.92 Sales Tax: \$0.00 -----
Shipping Speed: FREE Prime Delivery	Total for This Shipment: \$173.92 -----

Payment information	
Payment Method: Visa Last digits: 7978	Item(s) Subtotal: \$173.92 Shipping & Handling: \$0.00 -----
Billing address Ron Zastrocky 12788 MERITAGE BLVD JACKSONVILLE, FL 32246-0705 United States	Total before tax: \$173.92 Estimated Tax: \$0.00 ----- Grand Total: \$173.92

Credit Card transactions

Visa ending in 7978: October 3, 2023: \$173.92

To view the status of your order, return to [Order Summary](#) .

[Conditions of Use](#) | [Privacy Notice](#) © 1996-2020, Amazon.com, Inc.

BJ'S WHOLESALE CLUB
12200 Atlantic Blvd.
Jacksonville FL 3222

SITE:
DATE: 10/6/2023 108
TIME: 9:09:30

Tran#: 749068

PUMP: 07
PRODUCT: Unleaded
PRICE/GAL: \$3.249
QTY/GAL: 8.024
FUEL TOTAL \$26.07

Mer#: 134000001467381
Terminal : 00999002

Dev : G
Appr: 806080

Visa
Swiped
Type:
Preauthorization

Resp: APPROVED
Card Num :
XXXXXXXXXX7978
Bat#: 20231006926
Seq#: 2118

Ref :
32792054513638327947
2940513GCSSVCZ000000

00
6
AVS : Z (ZIP Code
matches but street
address does not)

10/06/2023 09:07:44

I agree to pay the
above Total Amount
according to Card
Issuer Agreement.

Exp: 11/23
XXXXXXXX1544
Term: 108
Appr: 1
Reference: 202181633

How can you save
\$0.10 or more/gal?
Go to BJs.com/gas.

THANK YOU FOR
SHOPPING AT BJ'S
WHOLESALE CLUB

Publix

Kernan Square Shopping Center

12620 Beach Boulevard

Jacksonville, FL 32246

Store Manager: Saneathia McIntyre

904-554-3580



0644 A6N 086 921

KRAZY GLUE ADV GEL	3.19 T
TAX EXEMPT	
Order Total	3.19
Grand Total	3.19
Credit Payment	3.19
Change	0.00
TAX FORGIVEN	0.24

Receipt ID: 0544 A6N 086 921

PRESTO!

Trace #: 082170

Reference #: 0636644599

Acct #: XXXXXX XXXXXX 7978

Purchase VISA

Amount: \$3.19

Auth #: 416000

CREDIT CARD	PURCHASE
A0000000031010	VISA CREDIT
Entry Method:	Chip Read
Mode:	Issuer

Your cashier was Martha

10/06/2023 15:00 S0544 R108 6921 C0213

Join the Publix family!
Apply today at apply.publix.jobs.
We're an equal opportunity employer.

Publix Super Markets, Inc.

MEMBERSHIP RENEWAL
Your Membership will be extended 12 months from the expiration date. Paid Memberships renewed more than two months after expiration will be extended for 12 months from the last day of the month of renewal.
See the company's BLS Membership Terms

Q Story time



12200 ATLANTIC BLVD.
JACKSONVILLE, FL

Club Mgr: Jeffrey Wellesley

Club: 108 Reg: 51 Trans: 1589

Cashier: 601 10/06/23 03:50pm

*** MEMBERSHIP ID. 10844629145 ***

*** MEMBERSHIP EXPIRES ON 05/24 ***

88949748675	JJUICE 32	11.99 N
85220100286	MCINTOSH	4.99 N
2800091342	MILK MORSELS	11.29 N
74069565355	CELERY STICK	1.99 N
3400094425	HERSHEY CHOC	14.99 T
2152754	ECPN-HERSHEY	2.50-N
4000058642	MARS 135CT	15.99 T
2152757	ECPN-MARS 13	2.00-N
88867010801	WF MANDARIN	6.99 N
71752411177	ORG BANANAS	2.98 N

2 @ 1.49

**** SUBTOTAL 66.71

FL 7.5% Tax 2.32

**** TOTAL 69.03

Manf. Coupon 3.00

*****7978 ENTRY: C

Purchase OK APPROVED

AUTH 416025

TERMINAL NUMBER 78073010851

10/06/23 03:52pm 108 51 1589 601

VISA CREDIT

AID: A0000000031010

Visa 66.03

CHANGE 0.00

TOTAL ITEMS= 9

Story Time

Publix

Kernan Square Shopping Center
12620 Beach Boulevard
Jacksonville, FL 32246

Store Manager: Saneathia McIntyre
904-564-3580



0644 A8N 052 412

RECALL TRANSACTION
TERMINAL: 105
TRANS-NO: 2410

PENG BRND DRY ICE			
7.64 lb @ 2.09/ lb		15.97	T
SEAGRAMS GINGER AL		8.79	T F
COCA-COLA CLASSIC		13.69	T F
CARMEL NHFCS DIP			
1 @ 2 FOR 8.00		4.00	F
You Saved 0.99			
CARMEL NHFCS DIP			
1 @ 2 FOR 8.00		4.00	F
You Saved 0.99			
CARMEL NHFCS DIP			
1 @ 2 FOR 8.00		4.00	F
You Saved 0.99			
LT CARAMEL NHFCS			
1 @ 2 FOR 8.00		4.00	F
You Saved 0.99			

TAX EXEMPT

Order Total	54.45
Grand Total	54.45
Credit Payment	54.45
Change	0.00
TAX FORGIVEN	2.88

Savings Summary

Special Price Savings 3.96

* Your Savings at Publix *
* 3.96 *

Receipt ID: 0644 A8N 052 412

PRESTO!
Trace #: 052963
Reference #: 0639169763
Acct #: XXXXXXXXXXXX7978
Purchase VISA
Amount: \$54.45
Auth #: 908071

CREDIT CARD	PURCHASE
A0000000031010	VISA CREDIT
Entry Method:	Chip Read
Mode:	Issuer

Cashier Confirmed - Age Over 18

Your cashier was Alyssa

10/08/2023 10:17 S0644 R105 2412 C0374

Join the Publix family!
Apply today at apply.publix.jobs.
We're an equal opportunity employer.

Publix Super Markets, Inc.



12200 ATLANTIC BLVD.
JACKSONVILLE, FL
Club Mgr. Jeffrey Wellesley

Club:108 Reg:5 Trans:1325
Cashier:517126 10/08/23 11:14am

*** MEMBERSHIP ID. 10844629145 ***
*** MEMBERSHIP EXPIRES ON 05/24 ***

88133400961 DUNKIN ORG 40.79 N
**** SUBTOTAL 40.79
**** TOTAL 40.79

*****7978 ENTRY: C
Purchase 00 APPROVED
AUTH 018051
TERMINAL NUMBER 7807301085
10/08/23 11:15am 108 5 1325 517126
VISA CREDIT
AID: A0000000031010

Visa 40.79
CHANGE 0.00
TOTAL ITEMS= 1

As a BJ's Member I JUST SAVED: \$8.16
BJ's Member Savings 8.16
Coupons Redeemed 0.00
Rewards Redeemed 0.00

Current BJ's Gas Savings
FuelSaver earned thru 10/07/23 0.00/gal
FuelSaver earned in this trx: 0.00/gal
Visit BJ's.com/Gas for more details

MEMBER COPY



1008108051325



<https://bit.ly/theupsstorePRER>

NO PURCHASE NECESSARY. Void where prohibited.
Ends 1/31/24. Must be US resident 18 years or older
to enter. Limit (1) entry per person per month.

For Official Rules visit
www.TheUPSStore.com/surveyrules2023

Need Package Help?

(lost/damaged)

Provide details so we can help:
<https://online.upscapital.com/tccp>

VISA *****7978 313111
10/13/2023 02:11 PM
TID 772591380001

Purchase

VISA CREDIT XXXXXXXXXXXXX7978
ENTRY METHOD CHIP
CVM SIGN
Invoice 0010038256
Clerk 26205
Response APPROVED
Auth Code 313111

EMV DETAILS

MODE CHIP
AID A0000000031010
TVR 8080008000
IAD 06011203A0A000
TSI 6800
ARC Z3
Amount USD \$14.12

ZASTROCKY/RONALD

*** CUSTOMER COPY ***

Office DEPOT OfficeMax

JACKSONVILLE - (904) 992-9040

10/14/2023 4:34 PM



VPTT559P353YRER4B

SALE	6737-2-836-936553-23.9.3	
603398	DTR,ECONO,OD,#	5.89 SS
420852	PD,STMP,#1,GEL	6.09 SS
	Subtotal:	11.98
	FL 7.0% Sales Tax	0.90
	Total:	12.88
	Visa 7978:	12.88

AUTH CODE 514153

TDS Chip Read

AID A0000000031010 VISA CREDIT

TVR 8000008000

CVS No Signature Required

Shop online at www.officedepot.com

WE WANT TO HEAR FROM YOU!

Visit survey.officedepot.com

and enter the survey code below

Q6KS KBJZ GX49

or scan the below QR code



October fest

Publix

Kernan Square Shopping Center
12620 Beach Boulevard
Jacksonville, FL 32246

Store Manager: Saneathia McIntyre
904-564-3580



0644 AEN 035 449

WHITE CLAW 12PK		
2 @ 18.49		36.98 T
SAM ADAMS 12PK		
3 @ 19.99		59.97 T
HEINEKEN 18PK CANS		24.49 T
You Saved	0.46	
MICH ULTRA 24PK		28.99 T
R GOLD THINS		
2 @ 3.99		7.98 F
ICE 16 LB		
3 @ 4.99		14.97 T F

TAX EXEMPT

Order Total		173.38
Grand Total		173.38
Credit	Payment	173.38
Change		0.00
TAX FORGIVEN		12.41

Savings Summary

Special Price Savings	0.46

* Your Savings at Publix *	
* 0.46 *	

Receipt ID: 0644 AEN 035 449

PRESTO!
Trace #: 033869
Reference #: 0481398619
Acct #: XXXXXXXXXXXX7978
Purchase VISA
Amount: \$173.38
Auth #: 614145

CREDIT CARD	PURCHASE
A0000000031010	VISA CREDIT
Entry Method:	Chip Read
Mode:	Issuer

Cashier Confirmed - Age Over 21

Your cashier was Isabella

10/14/2023 17:54 S0644 R103 5449 C0252

Join the Publix family!
Apply today at apply.publix.jobs.
We're an equal opportunity employer.

Publix Super Markets, Inc.



How doers
get more done™

12721 ATLANTIC BLVD
JACKSONVILLE, FL 32225 (904)2200822

6365 00061 52383 10/18/23 06:50 AM
SALE CASHIER NYMPHA

027541001235 BOTTLE WATER <A> 1/2 LITER WATER 24PK 2@4.98	9.96N
030699152643 MEND. PLATE <A> MENDING PLATE_3" GALV_2PK 2@4.17	8.34N
NLP Savings \$0.86	
017801970364 400W MH HID <A> FEIT 400W ED28 HID CLR METAL HALIDE	31.97N

	SUBTOTAL	50.27
	SALES TAX	0.00
TAX EXEMPT		
	TOTAL	\$50.27
XXXXXXXXXXXX7978 VISA		USD\$ 50.27
AUTH CODE 508115/1612884		TA
Chip Read		
AID A0000000031010		VISA CREDIT

PRO XTRA MEMBER STATEMENT

PRO XTRA ###-###-2277 SUMMARY
THIS RECEIPT PO/JOB NAME: TAMAYA

2023 PRO XTRA SPEND 10/17:	\$1,608.14
INCLUDES:	
2023 PROXTRA SAVINGS 10/17:	\$10.09

As of 10/18/2023 your Paint Rewards level is Member; Spend 993.02 more in qualifying paint purchases to earn Bronze (10.0% off) on select paint items.

Get the CREDIT LINE your business needs PLUS earn Perks 4X FASTER when you join Pro Xtra, register, & use your Pro Xtra Credit Card. Apply and SAVE UP TO \$100. Learn more at homedepot.com/credit

6365 10/18/23 06:50 AM



6365 61 52383 10/18/2023 9979

RETURN POLICY DEFINITIONS		
POLICY ID	DAYS	POLICY EXPIRES ON
A 1	90	01/16/2024

DID WE NAIL IT?

Take a short survey for a chance TO WIN
A \$5,000 HOME DEPOT GIFT CARD



How doers
get more done.

12721 ATLANTIC BLVD
JACKSONVILLE, FL 32225 (904)2200822

6365 00052 66671 10/20/23 12:33 PM
SALE CASHIER SHAYNE

611942083558 PVC M ADPTR <A> 5.22N
1-1/2"X1-1/4" PVC MALE ADAPTER SXMPT
611942038367 1-1/4 ADAPTR <A> 1.76N
1-1/4" PVC MALE ADAPTER SXMPT

SUBTOTAL 6.98
SALES TAX 0.00

TAX EXEMPT TOTAL \$6.98

XXXXXXXXXXXX7978 VISA USD\$ 6.98

AUTH CODE 110243/9523329 TA
Chip Read
AID A0000000031010 VISA CREDIT

PRO XTRA MEMBER STATEMENT

PRO XTRA ###-###-2277 SUMMARY
THIS RECEIPT PO/JOB NAME: TAMAYA

2023 PRO XTRA SPEND 10/19: \$1,672.63
INCLUDES:
2023 PROXTRA SAVINGS 10/19: \$10.09

As of 10/20/2023 your Paint Rewards level is Member; Spend 993.02 more in qualifying paint purchases to earn Bronze (10.0% off) on select paint items.

Get the CREDIT LINE your business needs PLUS earn Perks 4X FASTER when you join Pro Xtra, register, & use your Pro Xtra Credit Card. Apply and SAVE UP TO \$100. Learn more at homedepot.com/credit

6365 10/20/23 12:33 PM



6365 52 66671 10/20/2023 2177

RETURN POLICY DEFINITIONS
POLICY ID DAYS POLICY EXPIRES ON
A 1 90 01/18/2024

DID WE NAIL IT?

Take a short survey for a chance TO WIN
A \$5,000 HOME DEPOT GIFT CARD

Opine en español

www.homedepot.com/survey

User ID: H89 139996 133683
PASSWORD: 23520 133631

Entries must be completed within 14 days of purchase. Entrants must be 18 or older to enter. See complete rules on website. No purchase necessary.

amazon.com



SG7rxgf1c0

Your order of October 20, 2023 (Order ID 113-2361512-9541829)

Qty.	Item	Item Price	Total
1	Smead File Folder, 1/3-Cut Tab, Letter Size, Manila, 100 per Box (10381) Office Product B00YJJBNS B00YJJBNS 086486103817	\$20.47	\$20.47
1	Officemate Premium #1 Paper Clips, 1,000 Paper Clips (10 Boxes of 100 Each) (99916), Silver Office Product B002W6ZVMC B002W6ZVMC 315054262770	\$8.31	\$8.31

This shipment completes your order.

Subtotal	\$28.78
Shipping & Handling	\$2.99
Promotional Certificate	-\$2.99
Order Total	\$28.78
Paid via credit/debit	\$28.78

Return or replace your item

Visit [Amazon.com/returns](https://www.amazon.com/returns)



0/G7rxgf1c0/-2 of 2-//DJX2-CART-SAME-2/rush/0/1021-00:00/1020-10:31

A5 -
118

amazon.com



SCBfmgv1v0

Your order of October 20, 2023 (Order ID 113-6315027-7097063)

Qty.	Item	Item Price	Total
1	Mocsicka Fall Photography Backdrop Autumn Forest Scene Window Photography Background Fall Harvest Thanksgiving Day Newbo... Electronics X003V2HQZ7 WA6A6 MMB-210x150-AN3358 (Sold by Mocsicka Backdrop)	\$14.99	\$14.99
1	DSTELIN Binder Clips Paper Clamps Assorted Sizes 100 Count (Black), X Large, Large, Medium, Small, X Small and Micro, 6... Office Product X001THPKJZ A023 705020457055 (Sold by HZ JoIMO Corp)	\$7.99	\$7.99
1	Blue Sky 2024 Weekly and Monthly Planner, January - December, 8.5" x 11", Frosted Cover, Wirebound, Joselyn (110394-24) Unknown Binding B0CBQVJ87S B0CBQVJ87S 699931907757	\$15.79	\$15.79

We've sent this part of your order to ensure quicker service. The other items will ship separately.

Subtotal	\$38.77
Shipment Total	\$38.77
Paid via credit/debit	\$143.47

Return or replace your item
Visit [Amazon.com/returns](https://www.amazon.com/returns)

amazon.com



SGqT6fB1r0

Your order of October 20, 2023 (Order ID 113-6315027-7097063)

Qty.	Item	Item Price	Total
1	Cardinal Economy 3 Ring Binder, 3 Inch, Presentation View, White, Holds 625 Sheets, Nonstick, PVC Free, 4 Pack of Binder... Office Product B00FG2NAC2 B00FG2NAC2 083086004308	\$24.00	\$24.00

We've sent this part of your order to ensure quicker service. The other items will ship separately.

Subtotal	\$24.00
Shipment Total	\$24.00
Paid via credit/debit	\$143.47

Return or replace your item
Visit [Amazon.com/returns](https://www.amazon.com/returns)



0/GqT6fB1r0/-1 of 1-//JAX9-CART-B/next-1dc/0/1020-19:00/1020-10:44

SIOC

amazon.com



Your order of October 20, 2023 (Order ID 113-6315027-7097063)

Qty.	Item	Item Price	Total
7	Nestle Coffee mate Coffee Creamer, Original, Liquid Creamer Singles, Non Dairy, No Refrigeration, Box of 360 Nestle Coffee mate --- Grocery B00451ZJB0 B00451ZJB0 10050000350107	\$35.99	\$35.99
1	The Original Donut Shop Keurig Single-Serve K-Cup Pods, Regular Medium Roast Coffee, 12 Count (Pack of 6) The Original Donut Shop --- Unknown Binding B00108JAYG B00108JAYG 13099555085164	\$31.72	\$31.72

We've sent this part of your order to ensure quicker service. The other items will ship separately.

Subtotal	\$67.71
Shipment Total	\$67.71
Paid via credit/debit	\$143.47

Return or replace your item

Visit [Amazon.com/returns](https://www.amazon.com/returns)



01/GBFY8m1s0/-2 of 2-//JAX9-CART-B/nex*-1dc/0/1020-17:00/1020-10:09

A8-168

amazon.com



SCqmHd9520

Your order of October 20, 2023 (Order ID 113-6315027-7097063)

Qty.	Item	Item Price	Total
1	The Great Thanksgiving Feast: A Thanksgiving Story for Kids Ellis, Sonica --- Paperback BOCH22Q9GP BOCH22Q9GP 9798986528168	\$12.99	\$12.99

This shipment completes your order.

Subtotal	\$12.99
Order Total	\$12.99
Paid via credit/debit	\$143.47

Return or replace your item
Visit [Amazon.com/returns](https://www.amazon.com/returns)



0/GqmHd9520/-2 of 2-//DJX2-CART-B/next-1dc/0/1022-21:00/1022-01:16

D1-170



Your order of October 20, 2023 (Order ID 113-0935919-0100209)

Qty.	Item	Item Price	Total
1	TN436 Toner Cartridge High Yield Replacement Compatible for Brother TN 436 TN436BK TN436C TN433 TN431 for Brother HL-L83... X003T08R7N 215-GO-TN436-AASJc (Sold by Chou gradually)	\$64.99	\$64.99

This shipment completes your order.	Subtotal	\$64.99
	Order Total	\$64.99
	Paid via credit/debit	\$64.99

Return or replace your item
Visit [Amazon.com/returns](https://www.amazon.com/returns)

0/GqmHd9520/-2 of 2-//DJX2-CART-B/next-1dc/0/1022-21:00/1022-01:16

D1-170



Final Details for Order #112-0311809-7241832

Order Placed: October 24, 2023
PO number : ron
Amazon.com order number: 112-0311809-7241832
Order Total: \$479.97

Business order information
Location: DSD - Beach (Tamaya) GL code: 14000 Prepaid Expense Billable / Non-Billable: Non-Billable Cost center: Northeast

Shipped on October 24, 2023	
Items Ordered	Price
1 Of: <i>Stenner Pump 45m3 - Stenner Peristaltic Pump Adjustable Head - Rated at 1.1 to 22 gpd adjustable head. Rated at 25 psi. - Ideal Chlorine Injection Pump. 120 Volts, Model number 45MJL3A2S</i> Sold by: WaterChemicalSystems (seller profile) Product question? (Ask Seller) Business Price Condition: New	\$479.97
Shipping Address: Ron Zastrocky 12788 MERITAGE BLVD JACKSONVILLE, FL 32246-0705 United States	Item(s) Subtotal: \$479.97 Shipping & Handling: \$0.00 ----- Total before tax: \$479.97 Sales Tax: \$0.00 -----
Shipping Speed: Two-Day Shipping	Total for This Shipment: \$479.97 -----

Payment information	
Payment Method: Visa Last digits: 7978	Item(s) Subtotal: \$479.97 Shipping & Handling: \$0.00 -----
Billing address Ron Zastrocky 12788 MERITAGE BLVD JACKSONVILLE, FL 32246-0705 United States	Total before tax: \$479.97 Estimated Tax: \$0.00 ----- Grand Total: \$479.97
Credit Card transactions	Visa ending in 7978: October 24, 2023: \$479.97

To view the status of your order, return to [Order Summary](#) .

PINCH-A-PENNY POOL-PATIO-SPA

The Perfect People For A Perfect Pool

 Like Us on Facebook
For Our Special Offers!

Pinch A Penny 146
12220-117 Atlantic Boulevard
Jacksonville FL 32225
904 220-9490

Sales Receipt

Transaction #: 874886
Account #: 9043292277
Customer: RON ZASTROCKY
Date: 10/24/2023 Time: 9:09 AM
Cashier: Alliah D Register #: 2

Reference: TEX EXEMPT
85-801385552C-3

Item	Description	Amount
02122190	PRD FLEX WALL BRUSH NYLON/SS	\$41.99
03020120	CHLORINE FLOATER XL	\$19.99
54921887	30' THROW LINE W/ FLOAT	\$13.99
8350A	SL 4'X12' 3 PC TELE POLE	\$24.99
00931170	VALUE CHLOR 25 LB. LARGE TAB	\$164.99
S		

Sub Total \$265.95
Total \$265.95

SIDE TERMINAL Tendered \$265.95
Change Due \$0.00

AMOUNT: \$265.95
SIDE TERMINAL -- 265.95

Transaction Type: Sale
Reference Id: 583947036033
Approval Code: Approved
Response Code: 0
Response Message: Approved
Entry Method: ContactICc
Card Type: Visa

Cardholder: ZASTROCKY/RONALD
Last 4: 7978
AID: A0000000031010
ATC: 0090
AC: TC C157500A7023455



BNY MELLON

The Bank of New York Mellon Trust Company, N.A.

Account Statement

Statement Period 11/01/2023 Through 11/30/2023

Account 171066 Base Currency = USD
BEACH CDD 2013A ACQ CONST SUBACCT

CLIENT SERVICE MANAGER: CAROLINE COWART
4655 SALISBURY RD STE 300
AIM-324-0000
JACKSONVILLE, FL 32256
904-645-1919
CAROLINE.COWART@BNYMELLON.COM

Go Paperless.

Securely access your accounts online to view your statements. Ask your BNY Mellon contact how we can help you access your account balances and activity in real time, receive your reports, enter your own transactions or submit an audit confirmation online. Also be sure to ask how NEXEN(SM) Gateway, our new cloud-based ecosystem, can help you.

Visit us at www.bnymellon.com

Summary of Assets Held by Asset Classification

Asset Classification	Market Value	Cost	Accrued Income	Estimated Annual Income	Market Yield
No Assets Held					

Summary of Cash Transactions by Transaction Category

Transaction Category	Current Period			Year-to-Date	
	Income	Principal	Realized Gains/Losses	Income	Principal
OPENING BALANCE	0.00	0.00		0.00	0.00
CLOSING BALANCE	0.00	0.00	0.00	0.00	0.00

The above cash transactions summary is provided for information purposes only and may not reflect actual taxable income or deductible expenses as reportable under the Internal Revenue Code.

Statement of Transactions by Transaction Date

Transaction Date	Transaction Description	Income	Principal	Cost	Realized Gains/Losses
No Transactions This Period					

Cumulative realized capital gain and loss position from 12/31/2022 for securities held in principal of account:

Short Term: 0.00 * Long Term: 0.00 *

* The above gain and loss position does not include transactions where tax cost information is incomplete or unavailable.



BNY MELLON

The Bank of New York Mellon Trust Company, N.A.

Statement Period 11/01/2023 Through 11/30/2023

Account 171066 Base Currency = USD
BEACH CDD 2013A ACQ CONST SUBACCT

Cash and securities set forth on this Account Statement are held by The Bank of New York Mellon, an affiliate of The Bank of New York Mellon Trust Company, N.A. In addition, The Bank of New York Mellon Trust Company, N.A. may utilize subsidiaries and affiliates to provide services and certain products to the Account. Subsidiaries and affiliates may be compensated for their services and products.

The value of securities set forth on this Account Statement are obtained by The Bank of New York Mellon Trust Company, N.A., from its affiliate, The Bank of New York Mellon which determines such values for Corporate Trust on the basis of market prices and information obtained by The Bank of New York Mellon from unaffiliated third parties (including independent pricing vendors) ("third party pricing services"). The Bank of New York Mellon has not verified such market values or information and makes no assurances as to the accuracy or correctness of such market values or information or that the market values set forth on this Account Statement reflect the value of the securities that can be realized upon the sale of such securities. In addition, the market values for the securities set forth in this Account Statement may differ from the market prices and information for the same securities used by other business units of The Bank of New York Mellon Trust Company, N.A., The Bank of New York Mellon or their respective subsidiaries or affiliates based upon market prices and information received from other third party pricing services utilized by such other business units. Corporate Trust does not compare its market values with those used by, or reconcile different market values used by, other business units of The Bank of New York Mellon Trust Company, N.A., The Bank of New York Mellon or their respective subsidiaries or affiliates. Neither The Bank of New York Mellon Trust Company, N.A. nor The Bank of New York Mellon shall be liable for any loss, damage or expense incurred as a result of or arising from or related to the market values or information provided by third party pricing services or the differences in market prices or information provided by other third party pricing services.

e 026604 n 012559 a 02 t DOM i WI s 46/009



BNY MELLON

The Bank of New York Mellon Trust Company, N.A.

Account Statement

Statement Period 11/01/2023 Through 11/30/2023

Account 171068 Base Currency = USD
BEACH CDD 2013A SINKING FUND ACCT

CLIENT SERVICE MANAGER: CAROLINE COWART
4655 SALISBURY RD STE 300
AIM-324-0000
JACKSONVILLE, FL 32256
904-645-1919
CAROLINE.COWART@BNYMELLON.COM

Go Paperless.

Securely access your accounts online to view your statements. Ask your BNY Mellon contact how we can help you access your account balances and activity in real time, receive your reports, enter your own transactions or submit an audit confirmation online. Also be sure to ask how NEXEN(SM) Gateway, our new cloud-based ecosystem, can help you.

Visit us at www.bnymellon.com

Summary of Assets Held by Asset Classification

Asset Classification	Market Value	Cost	Accrued Income	Estimated Annual Income	Market Yield
No Assets Held					

Summary of Cash Transactions by Transaction Category

Transaction Category	Current Period			Year-to-Date	
	Income	Principal	Realized Gains/Losses	Income	Principal
OPENING BALANCE	0.00	0.00		0.00	0.00
OTHER CASH ADDITIONS	0.00	0.00	0.00	0.00	175,000.00
OTHER CASH DISBURSEMENTS	0.00	0.00	0.00	0.00	175,000.00 -
CLOSING BALANCE	0.00	0.00	0.00	0.00	0.00

The above cash transactions summary is provided for information purposes only and may not reflect actual taxable income or deductible expenses as reportable under the Internal Revenue Code.

Statement of Transactions by Transaction Date

Transaction Date	Transaction Description	Income	Principal	Cost	Realized Gains/Losses
No Transactions This Period					

Cumulative realized capital gain and loss position from 12/31/2022 for securities held in principal of account:

Short Term: 0.00 * Long Term: 0.00 *

* The above gain and loss position does not include transactions where tax cost information is incomplete or unavailable.



BNY MELLON

The Bank of New York Mellon Trust Company, N.A.

Statement Period 11/01/2023 Through 11/30/2023

Account 171068 Base Currency = USD

BEACH CDD 2013A SINKING FUND ACCT

Cash and securities set forth on this Account Statement are held by The Bank of New York Mellon, an affiliate of The Bank of New York Mellon Trust Company, N.A. In addition, The Bank of New York Mellon Trust Company, N.A. may utilize subsidiaries and affiliates to provide services and certain products to the Account. Subsidiaries and affiliates may be compensated for their services and products.

The value of securities set forth on this Account Statement are obtained by The Bank of New York Mellon Trust Company, N.A., from its affiliate, The Bank of New York Mellon which determines such values for Corporate Trust on the basis of market prices and information obtained by The Bank of New York Mellon from unaffiliated third parties (including independent pricing vendors) ("third party pricing services"). The Bank of New York Mellon has not verified such market values or information and makes no assurances as to the accuracy or correctness of such market values or information or that the market values set forth on this Account Statement reflect the value of the securities that can be realized upon the sale of such securities. In addition, the market values for the securities set forth in this Account Statement may differ from the market prices and information for the same securities used by other business units of The Bank of New York Mellon Trust Company, N.A., The Bank of New York Mellon or their respective subsidiaries or affiliates based upon market prices and information received from other third party pricing services utilized by such other business units. Corporate Trust does not compare its market values with those used by, or reconcile different market values used by, other business units of The Bank of New York Mellon Trust Company, N.A., The Bank of New York Mellon or their respective subsidiaries or affiliates. Neither The Bank of New York Mellon Trust Company, N.A. nor The Bank of New York Mellon shall be liable for any loss, damage or expense incurred as a result of or arising from or related to the market values or information provided by third party pricing services or the differences in market prices or information provided by other third party pricing services.

e 026605 n 012660 a 02 t DOM i WI s 46.011



BNY MELLON

The Bank of New York Mellon Trust Company, N.A.

Account Statement

Statement Period 11/01/2023 Through 11/30/2023

Account 171078 Base Currency = USD
BEACH CDD 2013A INTEREST ACCT

CLIENT SERVICE MANAGER: CAROLINE COWART
4655 SALISBURY RD STE 300
AIM-324-0000
JACKSONVILLE, FL 32256
904-645-1919
CAROLINE.COWART@BNYMELLON.COM

Go Paperless.

Securely access your accounts online to view your statements. Ask your BNY Mellon contact how we can help you access your account balances and activity in real time, receive your reports, enter your own transactions or submit an audit confirmation online. Also be sure to ask how NEXEN(SM) Gateway, our new cloud-based ecosystem, can help you.

Visit us at www.bnymellon.com

Summary of Assets Held by Asset Classification

Asset Classification	Market Value	Cost	Accrued Income	Estimated Annual Income	Market Yield
No Assets Held					

Summary of Cash Transactions by Transaction Category

Transaction Category	Current Period			Year-to-Date	
	Income	Principal	Realized Gains/Losses	Income	Principal
OPENING BALANCE	0.00	305,035.00		0.00	0.00
OTHER CASH ADDITIONS	0.00	0.00	0.00	0.00	616,460.00
OTHER CASH DISBURSEMENTS	0.00	305,035.00-	0.00	0.00	616,460.00-
CLOSING BALANCE	0.00	0.00	0.00	0.00	0.00

The above cash transactions summary is provided for information purposes only and may not reflect actual taxable income or deductible expenses as reportable under the Internal Revenue Code.

Statement of Transactions by Transaction Date

Transaction Date	Transaction Description	Income	Principal	Cost	Realized Gains/Losses
11/01/23	ACCOUNT OPENING PERIOD BALANCE	0.00	305,035.00	0.00	
11/01/23	Cash Debit TXN2122182 DS INTEREST	0.00	305,035.00-	0.00	0.00
11/01/23	ACCOUNT CLOSING DAILY BALANCE	0.00	0.00	0.00	0.00



BNY MELLON

The Bank of New York Mellon Trust Company, N.A.

Statement Period 11/01/2023 Through 11/30/2023

Account 171078 Base Currency = USD

BEACH CDD 2013A INTEREST ACCT

Statement of Transactions by Transaction Date - Continued

Transaction Date	Transaction Description	Income	Principal	Cost	Realized Gains/Losses
11/30/23	ACCOUNT CLOSING PERIOD BALANCE	0.00	0.00	0.00	0.00

Cumulative realized capital gain and loss position from 12/31/2022 for securities held in principal of account:

Short Term: 0.00 * Long Term: 0.00 *

* The above gain and loss position does not include transactions where tax cost information is incomplete or unavailable.

Cash and securities set forth on this Account Statement are held by The Bank of New York Mellon, an affiliate of The Bank of New York Mellon Trust Company, N.A. In addition, The Bank of New York Mellon Trust Company, N.A. may utilize subsidiaries and affiliates to provide services and certain products to the Account. Subsidiaries and affiliates may be compensated for their services and products.

The value of securities set forth on this Account Statement are obtained by The Bank of New York Mellon Trust Company, N.A., from its affiliate, The Bank of New York Mellon which determines such values for Corporate Trust on the basis of market prices and information obtained by The Bank of New York Mellon from unaffiliated third parties (including independent pricing vendors) ("third party pricing services"). The Bank of New York Mellon has not verified such market values or information and makes no assurances as to the accuracy or correctness of such market values or information or that the market values set forth on this Account Statement reflect the value of the securities that can be realized upon the sale of such securities. In addition, the market values for the securities set forth in this Account Statement may differ from the market prices and information for the same securities used by other business units of The Bank of New York Mellon Trust Company, N.A., The Bank of New York Mellon or their respective subsidiaries or affiliates based upon market prices and information received from other third party pricing services utilized by such other business units. Corporate Trust does not compare its market values with those used by, or reconcile different market values used by, other business units of The Bank of New York Mellon Trust Company, N.A., The Bank of New York Mellon or their respective subsidiaries or affiliates. Neither The Bank of New York Mellon Trust Company, N.A. nor The Bank of New York Mellon shall be liable for any loss, damage or expense incurred as a result of or arising from or related to the market values or information provided by third party pricing services or the differences in market prices or information provided by other third party pricing services.



BNY MELLON

The Bank of New York Mellon Trust Company, N.A.

Go Paperless.

Securely access your accounts online to view your statements. Ask your BNY Mellon contact how we can help you access your account balances and activity in real time, receive your reports, enter your own transactions or submit an audit confirmation online. Also be sure to ask how NEXEN(SM) Gateway, our new cloud-based ecosystem, can help you.

Visit us at www.bnymellon.com

Account Statement

Statement Period 11/01/2023 Through 11/30/2023

Account 171108 Base Currency = USD
BEACH CDD 2013A REDEMPTION ACCT

CLIENT SERVICE MANAGER: CAROLINE COWART
4655 SALISBURY RD STE 300
AIM-324-0000
JACKSONVILLE, FL 32256
904-645-1919
CAROLINE.COWART@BNYMELLON.COM

Account Overview

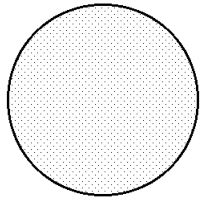

Percent of all Investments	Asset Classification	Market Value
100%	EQUITY	37.29
100%	TOTAL OF ALL INVESTMENTS	37.29

Summary of Assets Held by Asset Classification

Asset Classification	Market Value	Cost	Accrued Income	Estimated Annual Income	Market Yield
EQUITY	37.29	0.00	0.00	0.00	0.00 %
ACCOUNT TOTALS	37.29	0.00	0.00	0.00	0.00 %

Summary of Cash Transactions by Transaction Category

Transaction Category	Current Period			Year-to-Date	
	Income	Principal	Realized Gains/Losses	Income	Principal
OPENING BALANCE	0.00	0.00		0.00	0.00
CLOSING BALANCE	0.00	0.00	0.00	0.00	0.00

The above cash transactions summary is provided for information purposes only and may not reflect actual taxable income or deductible expenses as reportable under the Internal Revenue Code.



BNY MELLON

The Bank of New York Mellon Trust Company, N.A.

Statement Period 11/01/2023 Through 11/30/2023

Account 171108 Base Currency = USD

BEACH CDD 2013A REDEMPTION ACCT

Statement of Assets Held by Asset Classification

Shares/Par Value	Asset Description	Market Price	Market Value	Cost	Average Cost	Accrued Income	Estimated Income	Market Yield
EQUITY								
37.290	2013A SBA FLORIDA PRIME FD 322620 CUSIP: MM003M3HG	1.00000	37.29	0.00	0.00000	0.00	0.00	0.00%
Total EQUITY			37.29	0.00		0.00	0.00	0.00%
ACCOUNT TOTALS			37.29	0.00		0.00	0.00	0.00%

Total Market Value Plus Total Accrued Income 37.29

Statement of Transactions by Transaction Date

Transaction Date	Transaction Description	Income	Principal	Cost	Realized Gains/Losses
------------------	-------------------------	--------	-----------	------	-----------------------

No Transactions This Period

Cumulative realized capital gain and loss position from 12/31/2022 for securities held in principal of account:

Short Term: 0.00 * Long Term: 0.00 *

* The above gain and loss position does not include transactions where tax cost information is incomplete or unavailable.

Cash and securities set forth on this Account Statement are held by The Bank of New York Mellon, an affiliate of The Bank of New York Mellon Trust Company, N.A. In addition, The Bank of New York Mellon Trust Company, N.A. may utilize subsidiaries and affiliates to provide services and certain products to the Account. Subsidiaries and affiliates may be compensated for their services and products.

The value of securities set forth on this Account Statement are obtained by The Bank of New York Mellon Trust Company, N.A., from its affiliate, The Bank of New York Mellon which determines such values for Corporate Trust on the basis of market prices and information obtained by The Bank of New York Mellon from unaffiliated third parties (including independent pricing vendors) ("third party pricing services"). The Bank of New York Mellon has not verified such market values or information and makes no assurances as to the accuracy or correctness of such market values or information or that the market values set forth on this Account Statement reflect the value of the securities that can be realized upon the sale of such securities. In addition, the market values for the securities set forth in this Account Statement may differ from the market prices and information for the same securities used by other business units of The Bank of New York Mellon Trust Company, N.A., The Bank of New York Mellon or their respective subsidiaries or affiliates based upon market prices and information received from other third party pricing services utilized by such other business units. Corporate Trust does not compare its market values with those used by, or reconcile different market values used by, other business units of The Bank of New York Mellon Trust Company, N.A., The Bank of New York Mellon or their respective subsidiaries or affiliates. Neither The Bank of New York Mellon Trust Company, N.A. nor The Bank of New York Mellon shall be liable for any loss, damage or expense incurred as a result of or arising from or related to the market values or information provided by third party pricing services or the differences in market prices or information provided by other third party pricing services.



BNY MELLON

The Bank of New York Mellon Trust Company, N.A.

Account Statement

Statement Period 11/01/2023 Through 11/30/2023

Account 171120 Base Currency = USD
BEACH CDD 2013A PREPAYMENT SUBACCT

CLIENT SERVICE MANAGER: CAROLINE COWART
4655 SALISBURY RD STE 300
AIM-324-0000
JACKSONVILLE, FL 32256
904-645-1919
CAROLINE.COWART@BNYMELLON.COM

Go Paperless.

Securely access your accounts online to view your statements. Ask your BNY Mellon contact how we can help you access your account balances and activity in real time, receive your reports, enter your own transactions or submit an audit confirmation online. Also be sure to ask how NEXEN(SM) Gateway, our new cloud-based ecosystem, can help you.

Visit us at www.bnymellon.com

Account Overview

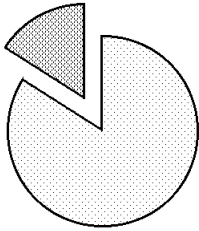

Percent of all Investments	Asset Classification	Market Value
85%	EQUITY	793.10
15%	CASH AND SHORT TERM	149.34
100%	TOTAL OF ALL INVESTMENTS	942.44

Summary of Assets Held by Asset Classification

Asset Classification	Market Value	Cost	Accrued Income	Estimated Annual Income	Market Yield
EQUITY	793.10	464.60	0.00	0.00	0.00 %
CASH AND SHORT TERM	149.34	149.34	0.00	0.00	0.00 %
ACCOUNT TOTALS	942.44	613.94	0.00	0.00	0.00 %

Summary of Cash Transactions by Transaction Category

Transaction Category	Current Period			Year-to-Date	
	Income	Principal	Realized Gains/Losses	Income	Principal
OPENING BALANCE	0.00	65,149.34		0.00	0.00
OTHER CASH ADDITIONS	0.00	0.00	0.00	0.00	81,543.14
OTHER CASH DISBURSEMENTS	0.00	65,000.00 -	0.00	0.00	81,393.80 -



BNY MELLON

The Bank of New York Mellon Trust Company, N.A.

Statement Period 11/01/2023 Through 11/30/2023

Account 171120 Base Currency = USD

BEACH CDD 2013A PREPAYMENT SUBACCT

Summary of Cash Transactions by Transaction Category - Continued

Transaction Category	Current Period			Year-to-Date	
	Income	Principal	Realized Gains/Losses	Income	Principal
CLOSING BALANCE	0.00	149.34	0.00	0.00	149.34

The above cash transactions summary is provided for information purposes only and may not reflect actual taxable income or deductible expenses as reportable under the Internal Revenue Code.

e 026612 n 012567 a 02 t DOM i W1 s 46035



BNY MELLON

The Bank of New York Mellon Trust Company, N.A.

Statement Period 11/01/2023 Through 11/30/2023

Account 171120 Base Currency = USD

BEACH CDD 2013A PREPAYMENT SUBACCT

Statement of Assets Held by Asset Classification

Shares/Par Value	Asset Description	Market Price	Market Value	Cost	Average Cost	Accrued Income	Estimated Income	Market Yield
EQUITY								
793.100	2013A SBA FLORIDA PRIME FD 322620 CUSIP: MM003M3HG	1.00000	793.10	464.60	0.58580	0.00	0.00	0.00%
Total EQUITY			793.10	464.60		0.00	0.00	0.00%
CASH AND SHORT TERM								
	CASH BALANCE		149.34	149.34	0.00000	0.00	0.00	0.00%
Total CASH AND SHORT TERM			149.34	149.34		0.00	0.00	0.00%
ACCOUNT TOTALS			942.44	613.94		0.00	0.00	0.00%

Total Market Value Plus Total Accrued Income 942.44

Statement of Transactions by Transaction Date

Transaction Date	Transaction Description	Income	Principal	Cost	Realized Gains/Losses
11/01/23	ACCOUNT OPENING PERIOD BALANCE	0.00	65,149.34	464.60	
11/01/23	Cash Debit TXN2122182 DS PREPAYMENT	0.00	65,000.00-	0.00	0.00
11/01/23	ACCOUNT CLOSING DAILY BALANCE	0.00	149.34	464.60	0.00
11/30/23	ACCOUNT CLOSING PERIOD BALANCE	0.00	149.34	464.60	0.00

Cumulative realized capital gain and loss position from 12/31/2022 for securities held in principal of account:

Short Term: 0.00 * Long Term: 0.00 *

* The above gain and loss position does not include transactions where tax cost information is incomplete or unavailable.

a 026612 n 012567 a 02 t DOM i W1 s 46036



BNY MELLON

The Bank of New York Mellon Trust Company, N.A.

Statement Period 11/01/2023 Through 11/30/2023

Account 171120

Base Currency = USD

BEACH CDD 2013A PREPAYMENT SUBACCT

Cash and securities set forth on this Account Statement are held by The Bank of New York Mellon, an affiliate of The Bank of New York Mellon Trust Company, N.A. In addition, The Bank of New York Mellon Trust Company, N.A. may utilize subsidiaries and affiliates to provide services and certain products to the Account. Subsidiaries and affiliates may be compensated for their services and products.

The value of securities set forth on this Account Statement are obtained by The Bank of New York Mellon Trust Company, N.A., from its affiliate, The Bank of New York Mellon which determines such values for Corporate Trust on the basis of market prices and information obtained by The Bank of New York Mellon from unaffiliated third parties (including independent pricing vendors) ("third party pricing services"). The Bank of New York Mellon has not verified such market values or information and makes no assurances as to the accuracy or correctness of such market values or information or that the market values set forth on this Account Statement reflect the value of the securities that can be realized upon the sale of such securities. In addition, the market values for the securities set forth in this Account Statement may differ from the market prices and information for the same securities used by other business units of The Bank of New York Mellon Trust Company, N.A., The Bank of New York Mellon or their respective subsidiaries or affiliates based upon market prices and information received from other third party pricing services utilized by such other business units. Corporate Trust does not compare its market values with those used by, or reconcile different market values used by, other business units of The Bank of New York Mellon Trust Company, N.A., The Bank of New York Mellon or their respective subsidiaries or affiliates. Neither The Bank of New York Mellon Trust Company, N.A. nor The Bank of New York Mellon shall be liable for any loss, damage or expense incurred as a result of or arising from or related to the market values or information provided by third party pricing services or the differences in market prices or information provided by other third party pricing services.

e 026612 n 012567 a 02 t DOM i WI s 46037



BNY MELLON

The Bank of New York Mellon Trust Company, N.A.

Account Statement

Statement Period 11/01/2023 Through 11/30/2023

Account 171126 Base Currency = USD
BEACH CDD 2013A OPT REDEMPT SUBACCT

CLIENT SERVICE MANAGER: CAROLINE COWART
4655 SALISBURY RD STE 300
AIM-324-0000
JACKSONVILLE, FL 32256
904-645-1919
CAROLINE.COWART@BNYMELLON.COM

Go Paperless.

Securely access your accounts online to view your statements. Ask your BNY Mellon contact how we can help you access your account balances and activity in real time, receive your reports, enter your own transactions or submit an audit confirmation online. Also be sure to ask how NEXEN(SM) Gateway, our new cloud-based ecosystem, can help you.

Visit us at www.bnymellon.com

Summary of Assets Held by Asset Classification

Asset Classification	Market Value	Cost	Accrued Income	Estimated Annual Income	Market Yield
No Assets Held					

Summary of Cash Transactions by Transaction Category

Transaction Category	Current Period			Year-to-Date	
	Income	Principal	Realized Gains/Losses	Income	Principal
OPENING BALANCE	0.00	0.00		0.00	0.00
CLOSING BALANCE	0.00	0.00	0.00	0.00	0.00

The above cash transactions summary is provided for information purposes only and may not reflect actual taxable income or deductible expenses as reportable under the Internal Revenue Code.

Statement of Transactions by Transaction Date

Transaction Date	Transaction Description	Income	Principal	Cost	Realized Gains/Losses
No Transactions This Period					

Cumulative realized capital gain and loss position from 12/31/2022 for securities held in principal of account:

Short Term: 0.00 * Long Term: 0.00 *

* The above gain and loss position does not include transactions where tax cost information is incomplete or unavailable.

a 026613 n 012568 a 02 1 DOM 1 W1 S 46038



BNY MELLON

The Bank of New York Mellon Trust Company, N.A.

Statement Period 11/01/2023 Through 11/30/2023

Account 171126 Base Currency = USD
BEACH CDD 2013A OPT REDEMPT SUBACCT

Cash and securities set forth on this Account Statement are held by The Bank of New York Mellon, an affiliate of The Bank of New York Mellon Trust Company, N.A. In addition, The Bank of New York Mellon Trust Company, N.A. may utilize subsidiaries and affiliates to provide services and certain products to the Account. Subsidiaries and affiliates may be compensated for their services and products.

The value of securities set forth on this Account Statement are obtained by The Bank of New York Mellon Trust Company, N.A., from its affiliate, The Bank of New York Mellon which determines such values for Corporate Trust on the basis of market prices and information obtained by The Bank of New York Mellon from unaffiliated third parties (including independent pricing vendors) ("third party pricing services"). The Bank of New York Mellon has not verified such market values or information and makes no assurances as to the accuracy or correctness of such market values or information or that the market values set forth on this Account Statement reflect the value of the securities that can be realized upon the sale of such securities. In addition, the market values for the securities set forth in this Account Statement may differ from the market prices and information for the same securities used by other business units of The Bank of New York Mellon Trust Company, N.A., The Bank of New York Mellon or their respective subsidiaries or affiliates based upon market prices and information received from other third party pricing services utilized by such other business units. Corporate Trust does not compare its market values with those used by, or reconcile different market values used by, other business units of The Bank of New York Mellon Trust Company, N.A., The Bank of New York Mellon or their respective subsidiaries or affiliates. Neither The Bank of New York Mellon Trust Company, N.A. nor The Bank of New York Mellon shall be liable for any loss, damage or expense incurred as a result of or arising from or related to the market values or information provided by third party pricing services or the differences in market prices or information provided by other third party pricing services.



BNY MELLON

The Bank of New York Mellon Trust Company, N.A.

Account Statement

Statement Period 11/01/2023 Through 11/30/2023

Account 171149 Base Currency = USD
BEACH CDD 2013A REVENUE ACCT

CLIENT SERVICE MANAGER: CAROLINE COWART
4655 SALISBURY RD STE 300
AIM-324-0000
JACKSONVILLE, FL 32256
904-645-1919
CAROLINE.COWART@BNYMELLON.COM

Go Paperless.

Securely access your accounts online to view your statements. Ask your BNY Mellon contact how we can help you access your account balances and activity in real time, receive your reports, enter your own transactions or submit an audit confirmation online. Also be sure to ask how NEXEN(SM) Gateway, our new cloud-based ecosystem, can help you.

Visit us at www.bnymellon.com

Account Overview

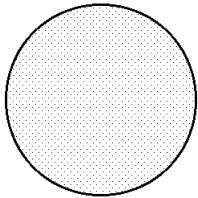

Percent of all Investments	Asset Classification	Market Value
100%	EQUITY	143,981.03
100%	TOTAL OF ALL INVESTMENTS	143,981.03

Summary of Assets Held by Asset Classification

Asset Classification	Market Value	Cost	Accrued Income	Estimated Annual Income	Market Yield
EQUITY	143,981.03	143,981.03	0.00	0.00	0.00 %
ACCOUNT TOTALS	143,981.03	143,981.03	0.00	0.00	0.00 %

Summary of Cash Transactions by Transaction Category

Transaction Category	Current Period			Year-to-Date	
	Income	Principal	Realized Gains/Losses	Income	Principal
OPENING BALANCE	0.00	0.00		0.00	0.00
OTHER CASH ADDITIONS	0.00	0.00	0.00	0.00	1,399,967.07
OTHER CASH DISBURSEMENTS	0.00	0.00	0.00	0.00	1,399,967.07-



BNY MELLON

The Bank of New York Mellon Trust Company, N.A.

Statement Period 11/01/2023 Through 11/30/2023

Account 171149 Base Currency = USD

BEACH CDD 2013A REVENUE ACCT

Summary of Cash Transactions by Transaction Category - Continued

Transaction Category	Current Period			Year-to-Date	
	Income	Principal	Realized Gains/Losses	Income	Principal
CLOSING BALANCE	0.00	0.00	0.00	0.00	0.00

The above cash transactions summary is provided for information purposes only and may not reflect actual taxable income or deductible expenses as reportable under the Internal Revenue Code.

e 026620 n 012575 a 02 t DOM i W1 s 46,057



BNY MELLON

The Bank of New York Mellon Trust Company, N.A.

Statement Period 11/01/2023 Through 11/30/2023

Account 171149 Base Currency = USD

BEACH CDD 2013A REVENUE ACCT

Statement of Assets Held by Asset Classification

Shares/Par Value	Asset Description	Market Price	Market Value	Cost	Average Cost	Accrued Income	Estimated Income	Market Yield
EQUITY								
143,981.030	2013A SBA FLORIDA PRIME FD 322620 CUSIP: MM003M3HG	1.00000	143,981.03	143,981.03	1.00000	0.00	0.00	0.00%
Total EQUITY			143,981.03	143,981.03		0.00	0.00	0.00%
ACCOUNT TOTALS			143,981.03	143,981.03		0.00	0.00	0.00%

Total Market Value Plus Total Accrued Income 143,981.03

Statement of Transactions by Transaction Date

Transaction Date	Transaction Description	Income	Principal	Cost	Realized Gains/Losses
11/01/23	ACCOUNT OPENING PERIOD BALANCE	0.00	0.00	142,478.47	
11/06/23	Receive 2013A SBA FLORIDA PRIME FD 322620 /IAS/OCTOBER 2023 INTEREST EARNINGS TRADE DATE 11/06/23 SET/DATE 11/06/23 CUSIP MM003M3HG 1,502.560 SHARES	0.00	0.00	1,502.56	0.00
11/06/23	ACCOUNT CLOSING DAILY BALANCE	0.00	0.00	143,981.03	0.00
11/30/23	ACCOUNT CLOSING PERIOD BALANCE	0.00	0.00	143,981.03	0.00

Cumulative realized capital gain and loss position from 12/31/2022 for securities held in principal of account:

Short Term: 0.00 * Long Term: 0.00 *

* The above gain and loss position does not include transactions where tax cost information is incomplete or unavailable.

Cash and securities set forth on this Account Statement are held by The Bank of New York Mellon, an affiliate of The Bank of New York Mellon Trust Company, N.A. In addition, The Bank of New York Mellon Trust Company, N.A. may utilize subsidiaries and affiliates to provide services and certain products to the Account. Subsidiaries and affiliates may be compensated for their services and products.

The value of securities set forth on this Account Statement are obtained by The Bank of New York Mellon Trust Company, N.A., from its affiliate, The Bank of New York Mellon which determines such values for Corporate Trust on the basis of market prices and information obtained by The Bank of New York Mellon from unaffiliated third parties (including independent pricing vendors) ("third party pricing services"). The Bank of New York Mellon has not verified such market values or information and makes no assurances as to the accuracy or correctness of such market values or information or that the market values set forth on this Account Statement reflect the value of the securities that can be realized upon the sale of such securities. In addition, the market values for the securities set forth in this Account Statement may differ from the market prices and information for the same securities used by other business units of The Bank of New York Mellon Trust Company, N.A., The Bank of New York Mellon or their respective subsidiaries or affiliates based upon market prices and information received from other third party pricing services utilized by such other business units. Corporate Trust does not compare its market values with those used by, or reconcile different market values used by, other business units of The Bank of New York Mellon Trust Company, N.A., The Bank of New York Mellon or their respective subsidiaries or affiliates. Neither The Bank of New York Mellon Trust Company, N.A. nor The Bank of New York Mellon shall be liable for any loss, damage or expense incurred as a result of or arising from or related to the market values or information provided by third party pricing services or the differences in market prices or information provided by other third party pricing services.



BNY MELLON

The Bank of New York Mellon Trust Company, N.A.

Account Statement

Statement Period 11/01/2023 Through 11/30/2023

Account 171167 Base Currency = USD
BEACH CDD 2013A REBATE ACCT

CLIENT SERVICE MANAGER: CAROLINE COWART
4655 SALISBURY RD STE 300
AIM-324-0000
JACKSONVILLE, FL 32256
904-645-1919
CAROLINE.COWART@BNYMELLON.COM

Go Paperless.

Securely access your accounts online to view your statements. Ask your BNY Mellon contact how we can help you access your account balances and activity in real time, receive your reports, enter your own transactions or submit an audit confirmation online. Also be sure to ask how NEXEN(SM) Gateway, our new cloud-based ecosystem, can help you.

Visit us at www.bnymellon.com

Summary of Assets Held by Asset Classification

Asset Classification	Market Value	Cost	Accrued Income	Estimated Annual Income	Market Yield
No Assets Held					

Summary of Cash Transactions by Transaction Category

Transaction Category	Current Period			Year-to-Date	
	Income	Principal	Realized Gains/Losses	Income	Principal
OPENING BALANCE	0.00	0.00		0.00	0.00
CLOSING BALANCE	0.00	0.00	0.00	0.00	0.00

The above cash transactions summary is provided for information purposes only and may not reflect actual taxable income or deductible expenses as reportable under the Internal Revenue Code.

Statement of Transactions by Transaction Date

Transaction Date	Transaction Description	Income	Principal	Cost	Realized Gains/Losses
No Transactions This Period					

Cumulative realized capital gain and loss position from 12/31/2022 for securities held in principal of account:

Short Term: 0.00 * Long Term: 0.00 *

* The above gain and loss position does not include transactions where tax cost information is incomplete or unavailable.

e 026627 n 012582 a 02 1 DOM 1 W1 S 46074



BNY MELLON

The Bank of New York Mellon Trust Company, N.A.

Statement Period 11/01/2023 Through 11/30/2023

Account 171167 Base Currency = USD

BEACH CDD 2013A REBATE ACCT

Cash and securities set forth on this Account Statement are held by The Bank of New York Mellon, an affiliate of The Bank of New York Mellon Trust Company, N.A. In addition, The Bank of New York Mellon Trust Company, N.A. may utilize subsidiaries and affiliates to provide services and certain products to the Account. Subsidiaries and affiliates may be compensated for their services and products.

The value of securities set forth on this Account Statement are obtained by The Bank of New York Mellon Trust Company, N.A., from its affiliate, The Bank of New York Mellon which determines such values for Corporate Trust on the basis of market prices and information obtained by The Bank of New York Mellon from unaffiliated third parties (including independent pricing vendors) ("third party pricing services"). The Bank of New York Mellon has not verified such market values or information and makes no assurances as to the accuracy or correctness of such market values or information or that the market values set forth on this Account Statement reflect the value of the securities that can be realized upon the sale of such securities. In addition, the market values for the securities set forth in this Account Statement may differ from the market prices and information for the same securities used by other business units of The Bank of New York Mellon Trust Company, N.A., The Bank of New York Mellon or their respective subsidiaries or affiliates based upon market prices and information received from other third party pricing services utilized by such other business units. Corporate Trust does not compare its market values with those used by, or reconcile different market values used by, other business units of The Bank of New York Mellon Trust Company, N.A., The Bank of New York Mellon or their respective subsidiaries or affiliates. Neither The Bank of New York Mellon Trust Company, N.A. nor The Bank of New York Mellon shall be liable for any loss, damage or expense incurred as a result of or arising from or related to the market values or information provided by third party pricing services or the differences in market prices or information provided by other third party pricing services.



BNY MELLON

The Bank of New York Mellon Trust Company, N.A.

Account Statement

Statement Period 11/01/2023 Through 11/30/2023

Account 171168 Base Currency = USD
BEACH CDD 2015A ACQ CONST SUBACCT

CLIENT SERVICE MANAGER: CAROLINE COWART
4655 SALISBURY RD STE 300
AIM-324-0000
JACKSONVILLE, FL 32256
904-645-1919
CAROLINE.COWART@BNYMELLON.COM

Go Paperless.

Securely access your accounts online to view your statements. Ask your BNY Mellon contact how we can help you access your account balances and activity in real time, receive your reports, enter your own transactions or submit an audit confirmation online. Also be sure to ask how NEXEN(SM) Gateway, our new cloud-based ecosystem, can help you.

Visit us at www.bnymellon.com

Summary of Assets Held by Asset Classification

Asset Classification	Market Value	Cost	Accrued Income	Estimated Annual Income	Market Yield
No Assets Held					

Summary of Cash Transactions by Transaction Category

Transaction Category	Current Period			Year-to-Date	
	Income	Principal	Realized Gains/Losses	Income	Principal
OPENING BALANCE	0.00	0.00		0.00	0.00
CLOSING BALANCE	0.00	0.00	0.00	0.00	0.00

The above cash transactions summary is provided for information purposes only and may not reflect actual taxable income or deductible expenses as reportable under the Internal Revenue Code.

Statement of Transactions by Transaction Date

Transaction Date	Transaction Description	Income	Principal	Cost	Realized Gains/Losses
No Transactions This Period					

Cumulative realized capital gain and loss position from 12/31/2022 for securities held in principal of account:

Short Term: 0.00 * Long Term: 0.00 *

* The above gain and loss position does not include transactions where tax cost information is incomplete or unavailable.



BNY MELLON

The Bank of New York Mellon Trust Company, N.A.

Statement Period 11/01/2023 Through 11/30/2023

Account 171168

Base Currency = USD

BEACH CDD 2015A ACQ CONST SUBACCT

Cash and securities set forth on this Account Statement are held by The Bank of New York Mellon, an affiliate of The Bank of New York Mellon Trust Company, N.A. In addition, The Bank of New York Mellon Trust Company, N.A. may utilize subsidiaries and affiliates to provide services and certain products to the Account. Subsidiaries and affiliates may be compensated for their services and products.

The value of securities set forth on this Account Statement are obtained by The Bank of New York Mellon Trust Company, N.A., from its affiliate, The Bank of New York Mellon which determines such values for Corporate Trust on the basis of market prices and information obtained by The Bank of New York Mellon from unaffiliated third parties (including independent pricing vendors) ("third party pricing services"). The Bank of New York Mellon has not verified such market values or information and makes no assurances as to the accuracy or correctness of such market values or information or that the market values set forth on this Account Statement reflect the value of the securities that can be realized upon the sale of such securities. In addition, the market values for the securities set forth in this Account Statement may differ from the market prices and information for the same securities used by other business units of The Bank of New York Mellon Trust Company, N.A., The Bank of New York Mellon or their respective subsidiaries or affiliates based upon market prices and information received from other third party pricing services utilized by such other business units. Corporate Trust does not compare its market values with those used by, or reconcile different market values used by, other business units of The Bank of New York Mellon Trust Company, N.A., The Bank of New York Mellon or their respective subsidiaries or affiliates. Neither The Bank of New York Mellon Trust Company, N.A. nor The Bank of New York Mellon shall be liable for any loss, damage or expense incurred as a result of or arising from or related to the market values or information provided by third party pricing services or the differences in market prices or information provided by other third party pricing services.

e 026628 n 012583 a 02 t DOM i WI s 46077



BNY MELLON

The Bank of New York Mellon Trust Company, N.A.

Go Paperless.

Securely access your accounts online to view your statements. Ask your BNY Mellon contact how we can help you access your account balances and activity in real time, receive your reports, enter your own transactions or submit an audit confirmation online. Also be sure to ask how NEXEN(SM) Gateway, our new cloud-based ecosystem, can help you.

Visit us at www.bnymellon.com

Account Statement

Statement Period 11/01/2023 Through 11/30/2023

Account 171170 Base Currency = USD
BEACH CDD 2015A SINKING FUND ACCT

CLIENT SERVICE MANAGER: CAROLINE COWART
4655 SALISBURY RD STE 300
AIM-324-0000
JACKSONVILLE, FL 32256
904-645-1919
CAROLINE.COWART@BNYMELLON.COM

Summary of Assets Held by Asset Classification

Asset Classification	Market Value	Cost	Accrued Income	Estimated Annual Income	Market Yield
No Assets Held					

Summary of Cash Transactions by Transaction Category

Transaction Category	Current Period			Year-to-Date	
	Income	Principal	Realized Gains/Losses	Income	Principal
OPENING BALANCE	0.00	0.00		0.00	0.00
OTHER CASH ADDITIONS	0.00	0.00	0.00	0.00	165,000.00
OTHER CASH DISBURSEMENTS	0.00	0.00	0.00	0.00	165,000.00 -
CLOSING BALANCE	0.00	0.00	0.00	0.00	0.00

The above cash transactions summary is provided for information purposes only and may not reflect actual taxable income or deductible expenses as reportable under the Internal Revenue Code.

Statement of Transactions by Transaction Date

Transaction Date	Transaction Description	Income	Principal	Cost	Realized Gains/Losses
No Transactions This Period					

Cumulative realized capital gain and loss position from 12/31/2022 for securities held in principal of account:

Short Term: 0.00 * Long Term: 0.00 *

* The above gain and loss position does not include transactions where tax cost information is incomplete or unavailable.

a 026629 n 012684 a 02 1 DOM 1 W1 S 46078



BNY MELLON

The Bank of New York Mellon Trust Company, N.A.

Statement Period 11/01/2023 Through 11/30/2023

Account 171170

Base Currency = USD

BEACH CDD 2015A SINKING FUND ACCT

Cash and securities set forth on this Account Statement are held by The Bank of New York Mellon, an affiliate of The Bank of New York Mellon Trust Company, N.A. In addition, The Bank of New York Mellon Trust Company, N.A. may utilize subsidiaries and affiliates to provide services and certain products to the Account. Subsidiaries and affiliates may be compensated for their services and products.

The value of securities set forth on this Account Statement are obtained by The Bank of New York Mellon Trust Company, N.A., from its affiliate, The Bank of New York Mellon which determines such values for Corporate Trust on the basis of market prices and information obtained by The Bank of New York Mellon from unaffiliated third parties (including independent pricing vendors) ("third party pricing services"). The Bank of New York Mellon has not verified such market values or information and makes no assurances as to the accuracy or correctness of such market values or information or that the market values set forth on this Account Statement reflect the value of the securities that can be realized upon the sale of such securities. In addition, the market values for the securities set forth in this Account Statement may differ from the market prices and information for the same securities used by other business units of The Bank of New York Mellon Trust Company, N.A., The Bank of New York Mellon or their respective subsidiaries or affiliates based upon market prices and information received from other third party pricing services utilized by such other business units. Corporate Trust does not compare its market values with those used by, or reconcile different market values used by, other business units of The Bank of New York Mellon Trust Company, N.A., The Bank of New York Mellon or their respective subsidiaries or affiliates. Neither The Bank of New York Mellon Trust Company, N.A. nor The Bank of New York Mellon shall be liable for any loss, damage or expense incurred as a result of or arising from or related to the market values or information provided by third party pricing services or the differences in market prices or information provided by other third party pricing services.

e 026629 n 012584 a 02 t DOM l WI s 46079



BNY MELLON

The Bank of New York Mellon Trust Company, N.A.

Account Statement

Statement Period 11/01/2023 Through 11/30/2023

Account 171171 Base Currency = USD
BEACH CDD 2015A INTEREST ACCT

CLIENT SERVICE MANAGER: CAROLINE COWART
4655 SALISBURY RD STE 300
AIM-324-0000
JACKSONVILLE, FL 32256
904-645-1919
CAROLINE.COWART@BNYMELLON.COM

Go Paperless.

Securely access your accounts online to view your statements. Ask your BNY Mellon contact how we can help you access your account balances and activity in real time, receive your reports, enter your own transactions or submit an audit confirmation online. Also be sure to ask how NEXEN(SM) Gateway, our new cloud-based ecosystem, can help you.

Visit us at www.bnymellon.com

Summary of Assets Held by Asset Classification

Asset Classification	Market Value	Cost	Accrued Income	Estimated Annual Income	Market Yield
No Assets Held					

Summary of Cash Transactions by Transaction Category

Transaction Category	Current Period			Year-to-Date	
	Income	Principal	Realized Gains/Losses	Income	Principal
OPENING BALANCE	0.00	217,120.00		0.00	0.00
OTHER CASH ADDITIONS	0.00	0.00	0.00	0.00	439,107.50
OTHER CASH DISBURSEMENTS	0.00	217,120.00-	0.00	0.00	439,107.50-
CLOSING BALANCE	0.00	0.00	0.00	0.00	0.00

The above cash transactions summary is provided for information purposes only and may not reflect actual taxable income or deductible expenses as reportable under the Internal Revenue Code.

Statement of Transactions by Transaction Date

Transaction Date	Transaction Description	Income	Principal	Cost	Realized Gains/Losses
11/01/23	ACCOUNT OPENING PERIOD BALANCE	0.00	217,120.00	0.00	
11/01/23	Cash Debit TXN2122183 DS INTEREST	0.00	217,120.00-	0.00	0.00
11/01/23	ACCOUNT CLOSING DAILY BALANCE	0.00	0.00	0.00	0.00



BNY MELLON

The Bank of New York Mellon Trust Company, N.A.

Statement Period 11/01/2023 Through 11/30/2023

Account 171171 Base Currency = USD

BEACH CDD 2015A INTEREST ACCT

Statement of Transactions by Transaction Date - Continued

Transaction Date	Transaction Description	Income	Principal	Cost	Realized Gains/Losses
11/30/23	ACCOUNT CLOSING PERIOD BALANCE	0.00	0.00	0.00	0.00

Cumulative realized capital gain and loss position from 12/31/2022 for securities held in principal of account:

Short Term: 0.00 * Long Term: 0.00 *

* The above gain and loss position does not include transactions where tax cost information is incomplete or unavailable.

Cash and securities set forth on this Account Statement are held by The Bank of New York Mellon, an affiliate of The Bank of New York Mellon Trust Company, N.A. In addition, The Bank of New York Mellon Trust Company, N.A. may utilize subsidiaries and affiliates to provide services and certain products to the Account. Subsidiaries and affiliates may be compensated for their services and products.

The value of securities set forth on this Account Statement are obtained by The Bank of New York Mellon Trust Company, N.A., from its affiliate, The Bank of New York Mellon which determines such values for Corporate Trust on the basis of market prices and information obtained by The Bank of New York Mellon from unaffiliated third parties (including independent pricing vendors) ("third party pricing services"). The Bank of New York Mellon has not verified such market values or information and makes no assurances as to the accuracy or correctness of such market values or information or that the market values set forth on this Account Statement reflect the value of the securities that can be realized upon the sale of such securities. In addition, the market values for the securities set forth in this Account Statement may differ from the market prices and information for the same securities used by other business units of The Bank of New York Mellon Trust Company, N.A., The Bank of New York Mellon or their respective subsidiaries or affiliates based upon market prices and information received from other third party pricing services utilized by such other business units. Corporate Trust does not compare its market values with those used by, or reconcile different market values used by, other business units of The Bank of New York Mellon Trust Company, N.A., The Bank of New York Mellon or their respective subsidiaries or affiliates. Neither The Bank of New York Mellon Trust Company, N.A. nor The Bank of New York Mellon shall be liable for any loss, damage or expense incurred as a result of or arising from or related to the market values or information provided by third party pricing services or the differences in market prices or information provided by other third party pricing services.



BNY MELLON

The Bank of New York Mellon Trust Company, N.A.

Go Paperless.

Securely access your accounts online to view your statements. Ask your BNY Mellon contact how we can help you access your account balances and activity in real time, receive your reports, enter your own transactions or submit an audit confirmation online. Also be sure to ask how NEXEN(SM) Gateway, our new cloud-based ecosystem, can help you.

Visit us at www.bnymellon.com

Account Statement

Statement Period 11/01/2023 Through 11/30/2023

Account 171172 Base Currency = USD
BEACH CDD 2015A REDEMPTION ACCT

CLIENT SERVICE MANAGER: CAROLINE COWART

4655 SALISBURY RD STE 300

AIM-324-0000

JACKSONVILLE, FL 32256

904-645-1919

CAROLINE.COWART@BNYMELLON.COM

Account Overview

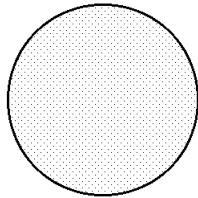

Percent of all Investments	Asset Classification	Market Value
100%	EQUITY	149.42
100%	TOTAL OF ALL INVESTMENTS	149.42

Summary of Assets Held by Asset Classification

Asset Classification	Market Value	Cost	Accrued Income	Estimated Annual Income	Market Yield
EQUITY	149.42	149.42	0.00	0.00	0.00 %
ACCOUNT TOTALS	149.42	149.42	0.00	0.00	0.00 %

Summary of Cash Transactions by Transaction Category

Transaction Category	Current Period			Year-to-Date	
	Income	Principal	Realized Gains/Losses	Income	Principal
OPENING BALANCE	0.00	0.00		0.00	0.00
OTHER CASH ADDITIONS	0.00	0.00	0.00	0.00	17,110.07
OTHER CASH DISBURSEMENTS	0.00	0.00	0.00	0.00	17,110.07-



BNY MELLON

The Bank of New York Mellon Trust Company, N.A.

Statement Period 11/01/2023 Through 11/30/2023

Account 171172 Base Currency = USD

BEACH CDD 2015A REDEMPTION ACCT

Summary of Cash Transactions by Transaction Category - Continued

Transaction Category	Current Period			Year-to-Date	
	Income	Principal	Realized Gains/Losses	Income	Principal
CLOSING BALANCE	0.00	0.00	0.00	0.00	0.00

The above cash transactions summary is provided for information purposes only and may not reflect actual taxable income or deductible expenses as reportable under the Internal Revenue Code.

e 026631 n 012586 a 02 t DOM i W1 s 46,083



BNY MELLON

The Bank of New York Mellon Trust Company, N.A.

Statement Period 11/01/2023 Through 11/30/2023

Account 171172 Base Currency = USD
BEACH CDD 2015A REDEMPTION ACCT

Statement of Assets Held by Asset Classification

Shares/Par Value	Asset Description	Market Price	Market Value	Cost	Average Cost	Accrued Income	Estimated Income	Market Yield
EQUITY								
149.420	2015A SBA FLORIDA PRIME FD 322622 CUSIP: MM003M3H6	1.00000	149.42	149.42	1.00000	0.00	0.00	0.00%
Total EQUITY			149.42	149.42		0.00	0.00	0.00%
ACCOUNT TOTALS			149.42	149.42		0.00	0.00	0.00%

Total Market Value Plus Total Accrued Income 149.42

Statement of Transactions by Transaction Date

Transaction Date	Transaction Description	Income	Principal	Cost	Realized Gains/Losses
------------------	-------------------------	--------	-----------	------	-----------------------

No Transactions This Period

Cumulative realized capital gain and loss position from 12/31/2022 for securities held in principal of account:

Short Term: 0.00 * Long Term: 0.00 *

* The above gain and loss position does not include transactions where tax cost information is incomplete or unavailable.

Cash and securities set forth on this Account Statement are held by The Bank of New York Mellon, an affiliate of The Bank of New York Mellon Trust Company, N.A. In addition, The Bank of New York Mellon Trust Company, N.A. may utilize subsidiaries and affiliates to provide services and certain products to the Account. Subsidiaries and affiliates may be compensated for their services and products.

The value of securities set forth on this Account Statement are obtained by The Bank of New York Mellon Trust Company, N.A., from its affiliate, The Bank of New York Mellon which determines such values for Corporate Trust on the basis of market prices and information obtained by The Bank of New York Mellon from unaffiliated third parties (including independent pricing vendors) ("third party pricing services"). The Bank of New York Mellon has not verified such market values or information and makes no assurances as to the accuracy or correctness of such market values or information or that the market values set forth on this Account Statement reflect the value of the securities that can be realized upon the sale of such securities. In addition, the market values for the securities set forth in this Account Statement may differ from the market prices and information for the same securities used by other business units of The Bank of New York Mellon Trust Company, N.A., The Bank of New York Mellon or their respective subsidiaries or affiliates based upon market prices and information received from other third party pricing services utilized by such other business units. Corporate Trust does not compare its market values with those used by, or reconcile different market values used by, other business units of The Bank of New York Mellon Trust Company, N.A., The Bank of New York Mellon or their respective subsidiaries or affiliates. Neither The Bank of New York Mellon Trust Company, N.A. nor The Bank of New York Mellon shall be liable for any loss, damage or expense incurred as a result of or arising from or related to the market values or information provided by third party pricing services or the differences in market prices or information provided by other third party pricing services.



BNY MELLON

The Bank of New York Mellon Trust Company, N.A.

Account Statement

Statement Period 11/01/2023 Through 11/30/2023

Account 171173 Base Currency = USD
BEACH CDD 2015A PREPAYMENT SUBACCT

CLIENT SERVICE MANAGER: CAROLINE COWART
4655 SALISBURY RD STE 300
AIM-324-0000
JACKSONVILLE, FL 32256
904-645-1919
CAROLINE.COWART@BNYMELLON.COM

Go Paperless.

Securely access your accounts online to view your statements. Ask your BNY Mellon contact how we can help you access your account balances and activity in real time, receive your reports, enter your own transactions or submit an audit confirmation online. Also be sure to ask how NEXEN(SM) Gateway, our new cloud-based ecosystem, can help you.

Visit us at www.bnymellon.com

Account Overview

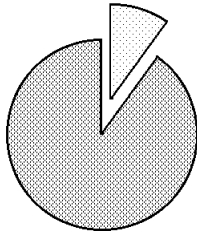

Percent of all Investments	Asset Classification	Market Value
9%	EQUITY	3,239.22
91%	CASH AND SHORT TERM	29,808.53
100%	TOTAL OF ALL INVESTMENTS	33,047.75

Summary of Assets Held by Asset Classification

Asset Classification	Market Value	Cost	Accrued Income	Estimated Annual Income	Market Yield
EQUITY	3,239.22	1,934.92	0.00	0.00	0.00 %
CASH AND SHORT TERM	29,808.53	29,808.53	0.00	0.00	0.00 %
ACCOUNT TOTALS	33,047.75	31,743.45	0.00	0.00	0.00 %

Summary of Cash Transactions by Transaction Category

Transaction Category	Current Period			Year-to-Date	
	Income	Principal	Realized Gains/Losses	Income	Principal
OPENING BALANCE	0.00	109,808.53		0.00	1,934.92
OTHER CASH ADDITIONS	0.00	0.00	0.00	0.00	113,678.37
OTHER CASH DISBURSEMENTS	0.00	80,000.00 -	0.00	0.00	85,804.76 -



BNY MELLON

The Bank of New York Mellon Trust Company, N.A.

Statement Period 11/01/2023 Through 11/30/2023

Account 171173 Base Currency = USD

BEACH CDD 2015A PREPAYMENT SUBACCT

Summary of Cash Transactions by Transaction Category - Continued

Transaction Category	Current Period			Year-to-Date	
	Income	Principal	Realized Gains/Losses	Income	Principal
CLOSING BALANCE	0.00	29,808.53	0.00	0.00	29,808.53

The above cash transactions summary is provided for information purposes only and may not reflect actual taxable income or deductible expenses as reportable under the Internal Revenue Code.

e 026632 n 012587 a 02 t DOM i W1 s 46,086



BNY MELLON

The Bank of New York Mellon Trust Company, N.A.

Statement Period 11/01/2023 Through 11/30/2023

Account 171173 Base Currency = USD

BEACH CDD 2015A PREPAYMENT SUBACCT

Statement of Assets Held by Asset Classification

Shares/Par Value	Asset Description	Market Price	Market Value	Cost	Average Cost	Accrued Income	Estimated Income	Market Yield
EQUITY								
3,239.220	2015A SBA FLORIDA PRIME FD 322622 CUSIP: MM003M3H6	1.00000	3,239.22	1,934.92	0.59734	0.00	0.00	0.00%
Total EQUITY			3,239.22	1,934.92		0.00	0.00	0.00%
CASH AND SHORT TERM								
	CASH BALANCE		29,808.53	29,808.53	0.00000	0.00	0.00	0.00%
Total CASH AND SHORT TERM			29,808.53	29,808.53		0.00	0.00	0.00%
ACCOUNT TOTALS			33,047.75	31,743.45		0.00	0.00	0.00%

Total Market Value Plus Total Accrued Income 33,047.75

Statement of Transactions by Transaction Date

Transaction Date	Transaction Description	Income	Principal	Cost	Realized Gains/Losses
11/01/23	ACCOUNT OPENING PERIOD BALANCE	0.00	109,808.53	1,934.92	
11/01/23	Cash Debit TXN2122183 DS PREPAYMENT	0.00	80,000.00-	0.00	0.00
11/01/23	ACCOUNT CLOSING DAILY BALANCE	0.00	29,808.53	1,934.92	0.00
11/30/23	ACCOUNT CLOSING PERIOD BALANCE	0.00	29,808.53	1,934.92	0.00

Cumulative realized capital gain and loss position from 12/31/2022 for securities held in principal of account:

Short Term: 0.00 * Long Term: 0.00 *

* The above gain and loss position does not include transactions where tax cost information is incomplete or unavailable.

a 026632 n 012587 a 02 t DOM i WI s 46087



BNY MELLON

The Bank of New York Mellon Trust Company, N.A.

Statement Period 11/01/2023 Through 11/30/2023

Account 171173

Base Currency = USD

BEACH CDD 2015A PREPAYMENT SUBACCT

Cash and securities set forth on this Account Statement are held by The Bank of New York Mellon, an affiliate of The Bank of New York Mellon Trust Company, N.A. In addition, The Bank of New York Mellon Trust Company, N.A. may utilize subsidiaries and affiliates to provide services and certain products to the Account. Subsidiaries and affiliates may be compensated for their services and products.

The value of securities set forth on this Account Statement are obtained by The Bank of New York Mellon Trust Company, N.A., from its affiliate, The Bank of New York Mellon which determines such values for Corporate Trust on the basis of market prices and information obtained by The Bank of New York Mellon from unaffiliated third parties (including independent pricing vendors) ("third party pricing services"). The Bank of New York Mellon has not verified such market values or information and makes no assurances as to the accuracy or correctness of such market values or information or that the market values set forth on this Account Statement reflect the value of the securities that can be realized upon the sale of such securities. In addition, the market values for the securities set forth in this Account Statement may differ from the market prices and information for the same securities used by other business units of The Bank of New York Mellon Trust Company, N.A., The Bank of New York Mellon or their respective subsidiaries or affiliates based upon market prices and information received from other third party pricing services utilized by such other business units. Corporate Trust does not compare its market values with those used by, or reconcile different market values used by, other business units of The Bank of New York Mellon Trust Company, N.A., The Bank of New York Mellon or their respective subsidiaries or affiliates. Neither The Bank of New York Mellon Trust Company, N.A. nor The Bank of New York Mellon shall be liable for any loss, damage or expense incurred as a result of or arising from or related to the market values or information provided by third party pricing services or the differences in market prices or information provided by other third party pricing services.

e 026632 n 012587 a 02 t DOM i WI s 46088



BNY MELLON

The Bank of New York Mellon Trust Company, N.A.

Go Paperless.

Securely access your accounts online to view your statements. Ask your BNY Mellon contact how we can help you access your account balances and activity in real time, receive your reports, enter your own transactions or submit an audit confirmation online. Also be sure to ask how NEXEN(SM) Gateway, our new cloud-based ecosystem, can help you.

Visit us at www.bnymellon.com

Account Statement

Statement Period 11/01/2023 Through 11/30/2023

Account 171175 Base Currency = USD
BEACH CDD 2015A OPT REDEMPT SUBACCT

CLIENT SERVICE MANAGER: CAROLINE COWART

4655 SALISBURY RD STE 300

AIM-324-0000

JACKSONVILLE, FL 32256

904-645-1919

CAROLINE.COWART@BNYMELLON.COM

Account Overview

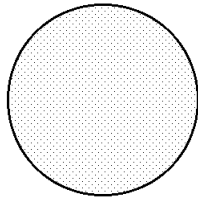

Percent of all Investments	Asset Classification	Market Value
100%	EQUITY	0.27
100%	TOTAL OF ALL INVESTMENTS	0.27

Summary of Assets Held by Asset Classification

Asset Classification	Market Value	Cost	Accrued Income	Estimated Annual Income	Market Yield
EQUITY	0.27	0.00	0.00	0.00	0.00 %
ACCOUNT TOTALS	0.27	0.00	0.00	0.00	0.00 %

Summary of Cash Transactions by Transaction Category

Transaction Category	Current Period			Year-to-Date	
	Income	Principal	Realized Gains/Losses	Income	Principal
OPENING BALANCE	0.00	0.00		0.00	0.00
CLOSING BALANCE	0.00	0.00	0.00	0.00	0.00

The above cash transactions summary is provided for information purposes only and may not reflect actual taxable income or deductible expenses as reportable under the Internal Revenue Code.



BNY MELLON

The Bank of New York Mellon Trust Company, N.A.

Statement Period 11/01/2023 Through 11/30/2023

Account 171175 Base Currency = USD

BEACH CDD 2015A OPT REDEMPT SUBACCT

Statement of Assets Held by Asset Classification

Shares/Par Value	Asset Description	Market Price	Market Value	Cost	Average Cost	Accrued Income	Estimated Income	Market Yield
EQUITY								
0.270	2015A SBA FLORIDA PRIME FD 322622 CUSIP: MM003M3H6	1.00000	0.27	0.00	0.00000	0.00	0.00	0.00%
Total EQUITY			0.27	0.00		0.00	0.00	0.00%
ACCOUNT TOTALS			0.27	0.00		0.00	0.00	0.00%

Total Market Value Plus Total Accrued Income 0.27

Statement of Transactions by Transaction Date

Transaction Date	Transaction Description	Income	Principal	Cost	Realized Gains/Losses
------------------	-------------------------	--------	-----------	------	-----------------------

No Transactions This Period

Cumulative realized capital gain and loss position from 12/31/2022 for securities held in principal of account:

Short Term: 0.00 * Long Term: 0.00 *

* The above gain and loss position does not include transactions where tax cost information is incomplete or unavailable.

Cash and securities set forth on this Account Statement are held by The Bank of New York Mellon, an affiliate of The Bank of New York Mellon Trust Company, N.A. In addition, The Bank of New York Mellon Trust Company, N.A. may utilize subsidiaries and affiliates to provide services and certain products to the Account. Subsidiaries and affiliates may be compensated for their services and products.

The value of securities set forth on this Account Statement are obtained by The Bank of New York Mellon Trust Company, N.A., from its affiliate, The Bank of New York Mellon which determines such values for Corporate Trust on the basis of market prices and information obtained by The Bank of New York Mellon from unaffiliated third parties (including independent pricing vendors) ("third party pricing services"). The Bank of New York Mellon has not verified such market values or information and makes no assurances as to the accuracy or correctness of such market values or information or that the market values set forth on this Account Statement reflect the value of the securities that can be realized upon the sale of such securities. In addition, the market values for the securities set forth in this Account Statement may differ from the market prices and information for the same securities used by other business units of The Bank of New York Mellon Trust Company, N.A., The Bank of New York Mellon or their respective subsidiaries or affiliates based upon market prices and information received from other third party pricing services utilized by such other business units. Corporate Trust does not compare its market values with those used by, or reconcile different market values used by, other business units of The Bank of New York Mellon Trust Company, N.A., The Bank of New York Mellon or their respective subsidiaries or affiliates. Neither The Bank of New York Mellon Trust Company, N.A. nor The Bank of New York Mellon shall be liable for any loss, damage or expense incurred as a result of or arising from or related to the market values or information provided by third party pricing services or the differences in market prices or information provided by other third party pricing services.



BNY MELLON

The Bank of New York Mellon Trust Company, N.A.

Go Paperless.

Securely access your accounts online to view your statements. Ask your BNY Mellon contact how we can help you access your account balances and activity in real time, receive your reports, enter your own transactions or submit an audit confirmation online. Also be sure to ask how NEXEN(SM) Gateway, our new cloud-based ecosystem, can help you.

Visit us at www.bnymellon.com

Account Statement

Statement Period 11/01/2023 Through 11/30/2023

Account 171177 Base Currency = USD
BEACH CDD 2015A REVENUE ACCT

CLIENT SERVICE MANAGER: CAROLINE COWART

4655 SALISBURY RD STE 300
AIM-324-0000
JACKSONVILLE, FL 32256
904-645-1919
CAROLINE.COWART@BNYMELLON.COM

Account Overview

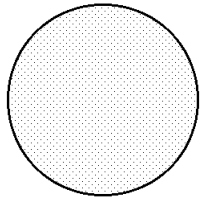

Percent of all Investments	Asset Classification	Market Value
100%	EQUITY	6,307.56
100%	TOTAL OF ALL INVESTMENTS	6,307.56

Summary of Assets Held by Asset Classification

Asset Classification	Market Value	Cost	Accrued Income	Estimated Annual Income	Market Yield
EQUITY	6,307.56	6,307.56	0.00	0.00	0.00 %
ACCOUNT TOTALS	6,307.56	6,307.56	0.00	0.00	0.00 %

Summary of Cash Transactions by Transaction Category

Transaction Category	Current Period			Year-to-Date	
	Income	Principal	Realized Gains/Losses	Income	Principal
OPENING BALANCE	0.00	0.00		0.00	6,236.72
OTHER CASH ADDITIONS	0.00	0.00	0.00	0.00	824,260.08
OTHER CASH DISBURSEMENTS	0.00	0.00	0.00	0.00	830,496.80-



BNY MELLON

The Bank of New York Mellon Trust Company, N.A.

Statement Period 11/01/2023 Through 11/30/2023

Account 171177 Base Currency = USD

BEACH CDD 2015A REVENUE ACCT

Summary of Cash Transactions by Transaction Category - Continued

Transaction Category	Current Period			Year-to-Date	
	Income	Principal	Realized Gains/Losses	Income	Principal
CLOSING BALANCE	0.00	0.00	0.00	0.00	0.00

The above cash transactions summary is provided for information purposes only and may not reflect actual taxable income or deductible expenses as reportable under the Internal Revenue Code.

e 026634 n 012589 a 02 t DOM i W1 s 46,092



BNY MELLON

The Bank of New York Mellon Trust Company, N.A.

Statement Period 11/01/2023 Through 11/30/2023

Account 171177

Base Currency = USD

BEACH CDD 2015A REVENUE ACCT

Statement of Assets Held by Asset Classification

Shares/Par Value	Asset Description	Market Price	Market Value	Cost	Average Cost	Accrued Income	Estimated Income	Market Yield
EQUITY								
6,307.560	2015A SBA FLORIDA PRIME FD 322622 CUSIP: MM003M3H6	1.00000	6,307.56	6,307.56	1.00000	0.00	0.00	0.00%
Total EQUITY			6,307.56	6,307.56		0.00	0.00	0.00%
ACCOUNT TOTALS			6,307.56	6,307.56		0.00	0.00	0.00%

Total Market Value Plus Total Accrued Income 6,307.56

Statement of Transactions by Transaction Date

Transaction Date	Transaction Description	Income	Principal	Cost	Realized Gains/Losses
11/01/23	ACCOUNT OPENING PERIOD BALANCE	0.00	0.00	5,934.63	
11/06/23	Receive 2015A SBA FLORIDA PRIME FD 322622 /IAS/OCTOBER 2023 INTEREST EARNINGS TRADE DATE 11/06/23 SET/DATE 11/06/23 CUSIP MM003M3H6 372.930 SHARES	0.00	0.00	372.93	0.00
11/06/23	ACCOUNT CLOSING DAILY BALANCE	0.00	0.00	6,307.56	0.00
11/30/23	ACCOUNT CLOSING PERIOD BALANCE	0.00	0.00	6,307.56	0.00

Cumulative realized capital gain and loss position from 12/31/2022 for securities held in principal of account:

Short Term: 0.00 * Long Term: 0.00 *

* The above gain and loss position does not include transactions where tax cost information is incomplete or unavailable.

Cash and securities set forth on this Account Statement are held by The Bank of New York Mellon, an affiliate of The Bank of New York Mellon Trust Company, N.A. In addition, The Bank of New York Mellon Trust Company, N.A. may utilize subsidiaries and affiliates to provide services and certain products to the Account. Subsidiaries and affiliates may be compensated for their services and products.

The value of securities set forth on this Account Statement are obtained by The Bank of New York Mellon Trust Company, N.A., from its affiliate, The Bank of New York Mellon which determines such values for Corporate Trust on the basis of market prices and information obtained by The Bank of New York Mellon from unaffiliated third parties (including independent pricing vendors) ("third party pricing services"). The Bank of New York Mellon has not verified such market values or information and makes no assurances as to the accuracy or correctness of such market values or information or that the market values set forth on this Account Statement reflect the value of the securities that can be realized upon the sale of such securities. In addition, the market values for the securities set forth in this Account Statement may differ from the market prices and information for the same securities used by other business units of The Bank of New York Mellon Trust Company, N.A., The Bank of New York Mellon or their respective subsidiaries or affiliates based upon market prices and information received from other third party pricing services utilized by such other business units. Corporate Trust does not compare its market values with those used by, or reconcile different market values used by, other business units of The Bank of New York Mellon Trust Company, N.A., The Bank of New York Mellon or their respective subsidiaries or affiliates. Neither The Bank of New York Mellon Trust Company, N.A. nor The Bank of New York Mellon shall be liable for any loss, damage or expense incurred as a result of or arising from or related to the market values or information provided by third party pricing services or the differences in market prices or information provided by other third party pricing services.



BNY MELLON

The Bank of New York Mellon Trust Company, N.A.

Account Statement

Statement Period 11/01/2023 Through 11/30/2023

Account 171178 Base Currency = USD
BEACH CDD 2015A REBATE ACCT

CLIENT SERVICE MANAGER: CAROLINE COWART
4655 SALISBURY RD STE 300
AIM-324-0000
JACKSONVILLE, FL 32256
904-645-1919
CAROLINE.COWART@BNYMELLON.COM

Go Paperless.

Securely access your accounts online to view your statements. Ask your BNY Mellon contact how we can help you access your account balances and activity in real time, receive your reports, enter your own transactions or submit an audit confirmation online. Also be sure to ask how NEXEN(SM) Gateway, our new cloud-based ecosystem, can help you.

Visit us at www.bnymellon.com

Summary of Assets Held by Asset Classification

Asset Classification	Market Value	Cost	Accrued Income	Estimated Annual Income	Market Yield
No Assets Held					

Summary of Cash Transactions by Transaction Category

Transaction Category	Current Period			Year-to-Date	
	Income	Principal	Realized Gains/Losses	Income	Principal
OPENING BALANCE	0.00	0.00		0.00	0.00
CLOSING BALANCE	0.00	0.00	0.00	0.00	0.00

The above cash transactions summary is provided for information purposes only and may not reflect actual taxable income or deductible expenses as reportable under the Internal Revenue Code.

Statement of Transactions by Transaction Date

Transaction Date	Transaction Description	Income	Principal	Cost	Realized Gains/Losses
No Transactions This Period					

Cumulative realized capital gain and loss position from 12/31/2022 for securities held in principal of account:

Short Term: 0.00 * Long Term: 0.00 *

* The above gain and loss position does not include transactions where tax cost information is incomplete or unavailable.

a 026635 n 012590 a 02 1 DOM 1 W1 S 46094



BNY MELLON

The Bank of New York Mellon Trust Company, N.A.

Statement Period 11/01/2023 Through 11/30/2023

Account 171178 Base Currency = USD

BEACH CDD 2015A REBATE ACCT

Cash and securities set forth on this Account Statement are held by The Bank of New York Mellon, an affiliate of The Bank of New York Mellon Trust Company, N.A. In addition, The Bank of New York Mellon Trust Company, N.A. may utilize subsidiaries and affiliates to provide services and certain products to the Account. Subsidiaries and affiliates may be compensated for their services and products.

The value of securities set forth on this Account Statement are obtained by The Bank of New York Mellon Trust Company, N.A., from its affiliate, The Bank of New York Mellon which determines such values for Corporate Trust on the basis of market prices and information obtained by The Bank of New York Mellon from unaffiliated third parties (including independent pricing vendors) ("third party pricing services"). The Bank of New York Mellon has not verified such market values or information and makes no assurances as to the accuracy or correctness of such market values or information or that the market values set forth on this Account Statement reflect the value of the securities that can be realized upon the sale of such securities. In addition, the market values for the securities set forth in this Account Statement may differ from the market prices and information for the same securities used by other business units of The Bank of New York Mellon Trust Company, N.A., The Bank of New York Mellon or their respective subsidiaries or affiliates based upon market prices and information received from other third party pricing services utilized by such other business units. Corporate Trust does not compare its market values with those used by, or reconcile different market values used by, other business units of The Bank of New York Mellon Trust Company, N.A., The Bank of New York Mellon or their respective subsidiaries or affiliates. Neither The Bank of New York Mellon Trust Company, N.A. nor The Bank of New York Mellon shall be liable for any loss, damage or expense incurred as a result of or arising from or related to the market values or information provided by third party pricing services or the differences in market prices or information provided by other third party pricing services.

e 026635 n 012690 a 02 t DOM l WI s 46095

EXHIBIT 11



Integrated Access Solutions
 INTEGRATION THAT WORKS FOR YOU

Integrated Access Solutions
 (904)894-8114
 2227 Crystal Cove Dr
 Green Cove Springs, FL 32043
 United States

Billed To
 Beach CDD
 Tamaya

Date of Issue
 10/16/2023

 Due Date
 10/16/2023

Invoice Number
 0004107

Amount Due (USD)
\$3,053.60

Description	Rate	Qty	Line Total
Mega Arm Tower Barrier Gate Direct ALL-IN-ONE OEM replacement. Includes all components except for the barrier arm.	\$2,789.60	1	\$2,789.60
Labor for installation, setup and testing Replacement, mounting, wiring, and testing of new operator.	\$132.00	2	\$264.00
	Subtotal		3,053.60
	Tax		0.00
	Total		3,053.60
	Amount Paid		0.00
	Amount Due (USD)		\$3,053.60

Notes

This is an estimate for a complete direct replacement of the driveway resident lane Liftmaster Mega Tower barrier arm operator. This product includes a 3-year manufacturer's warranty. It includes new backup batteries. This estimate serves as a replacement option instead of replacing a gearbox for the existing operator that is no longer functional. If accepted and approved, the recently installed motor replacement for the existing operator will be returned at no cost to the customer.

EXHIBIT 12



LLS Tax Solutions Inc.
2172 W. Nine Mile Rd.
#352
Pensacola, FL 32534
Telephone: 850-754-0311
Email: liscott@llstax.com

November 20, 2023

Beach Community Development District
c/o Vesta District Services
250 International Parkway, Suite 208
Lake Mary, Florida 32746

Thank you for choosing LLS Tax Solutions Inc. (“LLS Tax”) to provide arbitrage services to Beach Community Development District (“Client”) for the following bond issue. This Engagement Letter describes the scope of the LLS Tax services, the respective responsibilities of LLS Tax and Client relating to this engagement and the fees LLS Tax expects to charge.

- Beach Community Development District \$10,960,000 Capital Improvement Revenue Bonds, Series 2013A and \$7,115,000 Capital Improvement Revenue Bonds, Series 2013B

SCOPE OF SERVICES

The procedures that we will perform are as follows:

- Assist in calculation of the bond yield, unless previously computed and provided to us.
- Assist in determination of the amount, if any, of required rebate to the federal government.
- Issuance of a report presenting the cumulative results since the issue date of the issue of bonds.
- Preparation of necessary reports and Internal Revenue Service (“IRS”) forms to accompany any required payment to the federal government.

As a part of our engagement, we will read certain documents associated with each issue of bonds for which services are being rendered. We will determine gross proceeds of each issue of bonds based on the information provided in such bond documents. You will have sole responsibility for determining any other amounts not discussed in those documents that may constitute gross proceeds of each series of bonds for the purposes of the arbitrage requirements.

TAX POSITIONS AND REPORTABLE TRANSACTIONS

Because the tax law is not always clear, we will use our professional judgment in resolving questions affecting the arbitrage calculations. Unless you instruct us otherwise, we will take the reporting position most favorable to you whenever reasonable. Any of your bond issues may be selected for review by the IRS, which may not agree with our positions. Any proposed adjustments are subject to certain rights of appeal. Because of the lack of clarity in the law, we cannot provide assurances that

the positions asserted by the IRS may not ultimately be sustained, which could result in the assessment of potential penalties. You have the ultimate responsibility for your compliance with the arbitrage laws; therefore, you should review the calculations carefully.

The IRS and some states have promulgated “tax shelter” rules that require taxpayers to disclose their participation in “reportable transactions” by attaching a disclosure form to their federal and/or state income tax returns and, when necessary, by filing a copy with the Internal Revenue Service and/or the applicable state agency. These rules impose significant requirements to disclose transactions and such disclosures may encompass many transactions entered into in the normal course of business. Failure to make such disclosures will result in substantial penalties. In addition, an excise tax is imposed on exempt organizations (including state and local governments) that are a party to prohibited tax shelter transactions (which are defined using the reportable transaction rules). Client is responsible for ensuring that it has properly disclosed all “reportable transactions” and, where applicable, complied with the excise tax provision. The LLS Tax services that are the subject of this Engagement Letter do not include any undertaking by LLS Tax to identify any reportable transactions that have not been the subject of a prior consultation between LLS Tax and Client. Such services, if desired by Client, will be the subject of a separate engagement letter. LLS Tax may also be required to report to the IRS or certain state tax authorities certain tax services or transactions as well as Client’s participation therein. The determination of whether, when and to what extent LLS Tax complies with its federal or state “tax shelter” reporting requirements will be made exclusively by LLS Tax. LLS Tax will not be liable for any penalties resulting from Client’s failure to accurately and timely file any required disclosure or pay any related excise tax nor will LLS Tax be held responsible for any consequences of its own compliance with its reporting obligations. Please note that any disclosure required by or made pursuant to the tax shelter rules is separate and distinct from any other disclosure that Client might be required to or choose to make with its tax returns (e.g., disclosure on federal Form 8275 or similar state disclosure).

PROFESSIONAL FEES AND EXPENSES

Our professional fees for the services listed above for the two annual bond years ending November 3, 2024, and November 3, 2025, is \$1,300, which is \$650 for each year. We will bill you upon completion of our services. Our invoices are payable upon receipt. Additionally, you may request additional consulting services from us upon occasion; we will bill you for these consulting services at a beforehand agreed upon rate.

Unanticipated factors that could increase our fees beyond the estimate given above include the following (without limitation). Should any of these factors arise we will alert you before additional fees are incurred.

- Investment data provided by you is not in good order or is unusually voluminous.
- Proceeds of bonds have been commingled with amounts not considered gross proceeds of the bonds (if that circumstance has not previously been communicated to us).
- A review or other inquiry by the IRS with respect to an issue of bonds.

The Client (District) has the option to terminate this Agreement within ninety days of providing notice to LLS Tax Solutions Inc. of its intent.

ACCEPTANCE

You understand that the arbitrage services, report and IRS forms described above are solely to assist you in meeting your requirements for federal income tax compliance purposes. This Engagement Letter constitutes the entire agreement between Client and LLS Tax with respect to this engagement, supersedes all other oral and written representations, understandings or agreements relating to this engagement, and may not be amended except by the mutual written agreement of the Client and LLS Tax.

Please indicate your acceptance of this agreement by signing in the space provided below and returning a copy of this Engagement Letter to us. Thank you again for this opportunity to work with you.

Very truly yours,
LLS Tax Solutions Inc.

AGREED AND ACCEPTED:
Beach Community Development District

By: Linda L. Scott

Linda L. Scott, CPA

By: _____

Print Name _____

Title _____

Date: _____

EXHIBIT 13

MEMO

To: Beach CDD Board of Directors

From: Mike Veazey

Re: Parcel Transfer: we are respectfully requesting that the Beach CDD consider accepting the Deeds for below Parcels of Property that are affiliated with Tamaya. Below are descriptions of the parcels, attached are the sketch and legals, photos of the parcels, and pictures showing the current condition. If you have any questions do not hesitate to contact me.

CDD Transfer Parcel 1: this is an out parcel that was purchased for the possible Force Main extension that was required for permitting through JEA for approval of the project. The current condition is wooded with no improvements, the parcel was not needed for the force main extension.

CDD Transfer Parcel 2: this is an out parcel that was purchased for the possible Force Main extension that was required for permitting through JEA for approval of the project. The current condition is wooded with no improvements, the parcel was not needed for the force main extension.

CDD Transfer Parcel 3: this is an out parcel that was purchased for the possible Force Main extension that was required for permitting through JEA for approval of the project. The current condition is wooded with no improvements, the parcel was not needed for the force main extension.

CDD Transfer Parcel 4: This parcel is located on the west side of Beach Blvd. entrance to Tamaya, it has the main entry hardscape and landscape. These improvements were contracted and paid for by the Beach CDD and have been maintained by the Beach CDD since constructed.

CDD Transfer Parcel 5: This parcel is located on the west side of Tamaya Blvd. and Meritage Blvd intersection. It has the hardscape and landscape for the Exit Feature. These improvements were contracted and paid for by the Beach CDD and have been maintained by the Beach CDD since constructed.

CDD Transfer Parcel 6: This parcel is located between Tamaya Blvd and LIV at Tamaya (Parcel F) and is under conservation and a wetland. This parcel is wooded and in a natural state.

CDD Transfer Parcel 7: This parcel runs adjacent to Tamaya Blvd on the north side between the road and the JEA Easement. Currently the parcel has landscape on the west end. The east side has some fill and trash from illegal dumping. We are scheduling the cleanup of this parcel now and hope to have it completed by the end of the year.

Sincerely

Mike Veazey

EXHIBIT 14

October 26, 2023

Work Order No. 22-164.04
File No. 128H-20.04A

CDD Transfer Parcel 1

A portion of Section 29, Township 2 South, Range 28 East, Duval County, Florida, being the same lands as described and recorded in Official Records Book 17069, page 35, of the current Public Records of said county, being more particularly described as follows:

For a Point of Reference, commence at the Southwesterly corner of Coachman Meadows Unit One, as recorded in Plat Book 54, pages 89, 89A through 89B, of said current Public Records, said corner lying on the Northerly right of way line of Alden Road, a variable width right of way as presently established; thence Westerly along said Northerly right of way the following 3 courses: Course 1, thence South 89°54'16" West, 600.00 feet; Course 2, thence North 00°23'53" West, 20.00 feet; Course 3, thence South 87°53'01" West, 600.00 feet to the Southwesterly corner of those lands described and recorded in Official Records Book 13034, page 270, of said current Public Records and the Point of Beginning.

From said Point of Beginning, thence continue South 87°53'01" West, along said Northerly right of way line, 348.32 feet to the Southwesterly corner of those lands described and recorded in said Official Records Book 17069, page 35, said corner lying on the Westerly line of that certain 45 foot Lateral Ditch right of way, as depicted on Alden Trace Unit Three, recorded in Plat Book 42, pages 60, 60A through 60C, of said current Public Records; thence North 02°21'54" West, departing said Northerly right of way line and along said Westerly line, 42.52 feet to an angle point; thence North 14°00'55" East, continuing along said Westerly line, along the Easterly line of said Alden Tract Unit Three and along its Northerly prolongation, 1483.58 feet to a point lying on the Southerly right of way line of that certain 40 foot Drainage Right of Way, as described and recorded in Official Records Volume 824, page 384, of said current Public Records; thence North 89°55'24" East, along said Southerly right of way line, 50.07 feet to the Northwesterly corner of those lands described and recorded in said Official Records Book 13034, page 270; thence South 02°19'14" West, departing said Southerly right of way line and along the Westerly line of last said lands, 1470.31 feet to the Point of Beginning.

Containing 6.92 acres, more or less.

**SKETCH TO ACCOMPANY DESCRIPTION OF
A PORTION OF SECTION 29, TOWNSHIP 2 SOUTH, RANGE 28 EAST,
DUVAL COUNTY, FLORIDA, BEING THE SAME LANDS AS DESCRIBED
AND RECORDED IN OFFICIAL RECORDS BOOK 17069, PAGE 35,
OF THE CURRENT PUBLIC RECORDS OF SAID COUNTY,
BEING MORE PARTICULARLY DESCRIBED IN SEPARATE ATTACHMENT.**

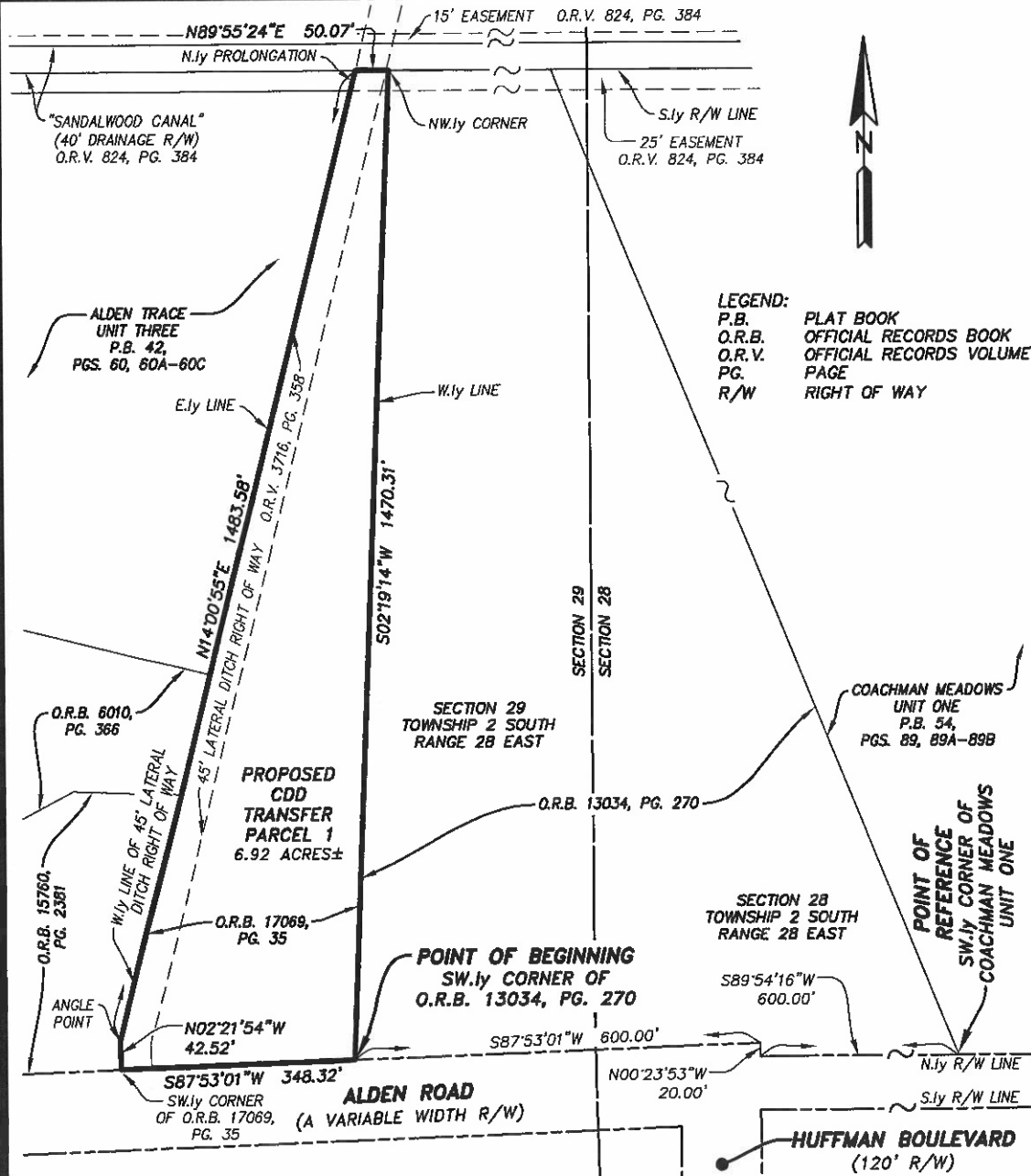

GENERAL NOTES:
1) THIS IS NOT A SURVEY.
2) BEARINGS BASED ON THE NORTHERLY RIGHT OF WAY LINE OF ALDEN ROAD AS BEING SOUTH 89°54'16" WEST.

ETM
Surveying & Mapping, Inc.
VISION • EXPERIENCE • RESULTS

14775 Old St. Augustine Road, Jacksonville, FL 32258
Tel: (904) 642-8550 Fax: (904) 642-4165
Certificate of Authorization No.: LB 3624

THIS ITEM HAS BEEN ELECTRONICALLY SIGNED AND SEALED USING A DIGITAL SIGNATURE. PRINTED COPIES OF THIS DOCUMENT ARE NOT CONSIDERED SIGNED AND SEALED AND THE SIGNATURE MUST BE VERIFIED ON ANY ELECTRONIC COPIES.



Digital Signature
by: Bob L. Pittman, P.S.M.

SCALE: 1"=200'
DATE: OCTOBER 26, 2023
BOB L. PITTMAN
PROFESSIONAL SURVEYOR AND MAPPER
STATE OF FLORIDA PSM No. 4827



Mike Veazey

From: Mike Veazey
Sent: Tuesday, December 5, 2023 10:18 AM
To: Mike Veazey
Subject: Parcel 1



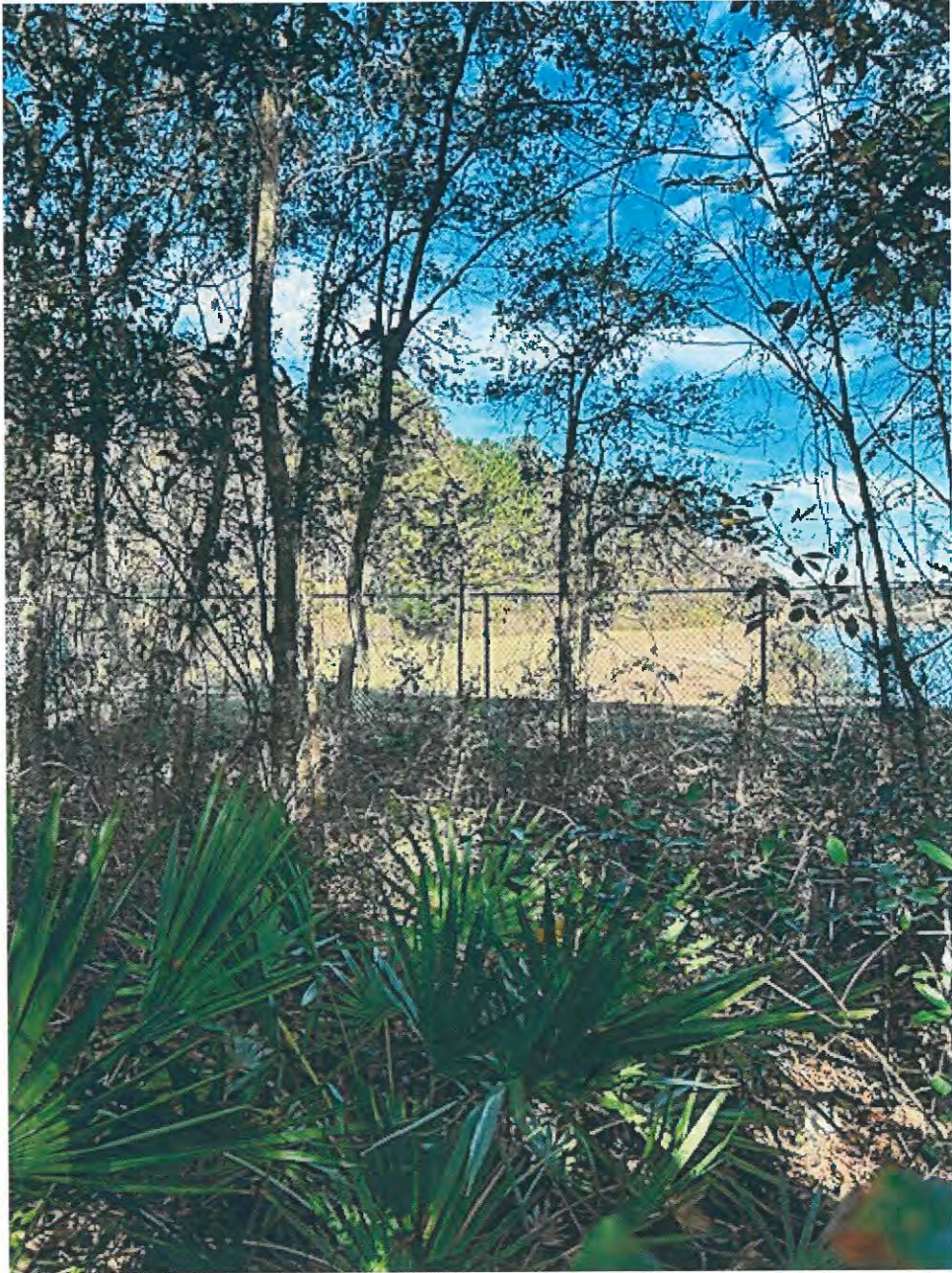



Sent from my iPhone

EXHIBIT 15

October 26, 2023

Work Order No. 22-164.04

File No. 128H-20.04B

CDD Transfer Parcel 2

A portion of Section 29, Township 2 South, Range 28 East, Duval County, Florida, being the same lands as described and recorded in Official Records Book 17069, page 35, of the current Public Records of said county, being more particularly described as follows:

For a Point of Beginning, commence at the Northeasterly corner of Alden Trace Unit Three, as recorded in Plat Book 43, pages 60, 60A through 60C, of said current Public Records; thence South $89^{\circ}57'25''$ West, along the Northerly line of said Alden Trace Unit Three, along the Northerly line of Alden Trace Unit Two, as recorded in Plat Book 41, pages 36 and 36A, and along the Northerly line of Alden Trace Unit One, as recorded in Plat Book 39, pages 44 and 44A, both of said current Public Records, 2241.89 feet to a point lying on the Easterly line of those lands described and recorded in Official Records Book 15580, page 2112, of said current Public Records; thence North $13^{\circ}06'03''$ West, departing said Northerly line and along said Easterly line, 25.66 feet to a point lying on the Southerly right of way line of that certain 40 foot Drainage right of way, as depicted on said Alden Trace Units One, Two and Three; thence North $89^{\circ}57'25''$ East, departing said Easterly line and along said Southerly right of way line, 2253.96 feet to a point lying on the Northerly prolongation of the Easterly line of said Alden Trace Unit Three; thence South $14^{\circ}02'56''$ West, departing said Southerly right of way line and along said Northerly prolongation, 25.78 feet to the Point of Beginning.

Containing 1.29 acres, more or less.

**SKETCH TO ACCOMPANY DESCRIPTION OF
A PORTION OF SECTION 29, TOWNSHIP 2 SOUTH, RANGE 28 EAST,
DUVAL COUNTY, FLORIDA, BEING THE SAME LANDS AS DESCRIBED
AND RECORDED IN OFFICIAL RECORDS BOOK 17069, PAGE 35,
OF THE CURRENT PUBLIC RECORDS OF SAID COUNTY,
BEING MORE PARTICULARLY DESCRIBED IN SEPARATE ATTACHMENT.**

LINE TABLE		
LINE	BEARING	LENGTH
L1	N13°06'03"W	25.66'
L2	S14°02'56"W	25.78'

LEGEND:
P.B. PLAT BOOK
O.R.B. OFFICIAL RECORDS BOOK
O.R.V. OFFICIAL RECORDS VOLUME
PG. PAGE
R/W RIGHT OF WAY
L1 TABULATED LINE DATA

SECTION 29
TOWNSHIP 2 SOUTH
RANGE 28 EAST

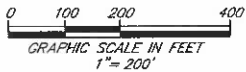
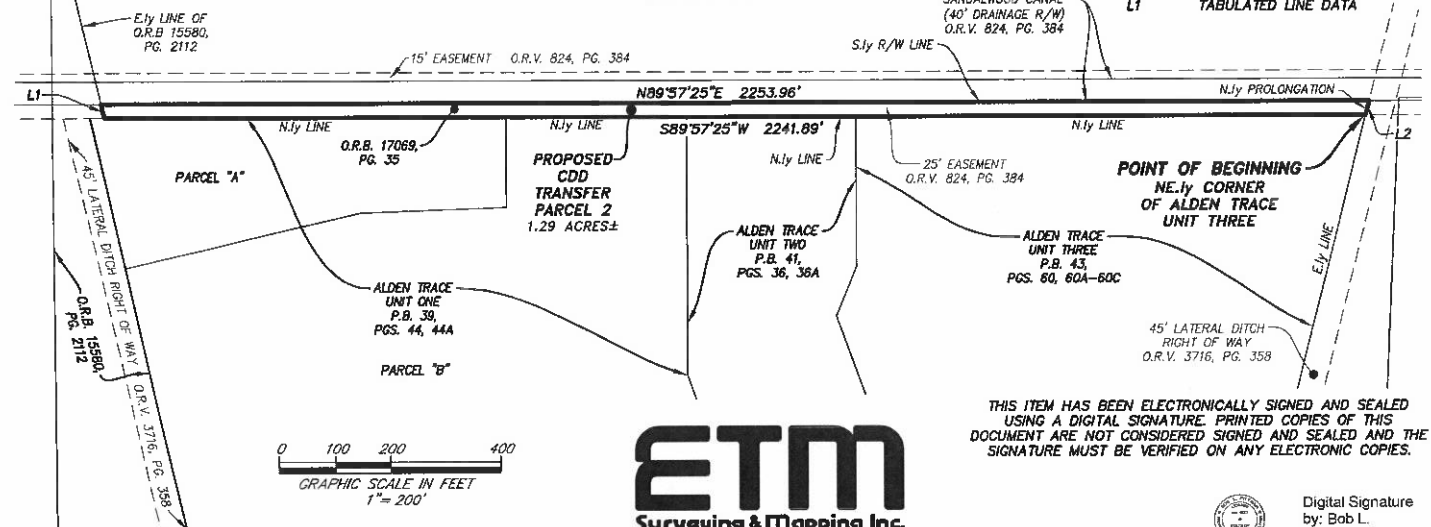

THIS ITEM HAS BEEN ELECTRONICALLY SIGNED AND SEALED USING A DIGITAL SIGNATURE. PRINTED COPIES OF THIS DOCUMENT ARE NOT CONSIDERED SIGNED AND SEALED AND THE SIGNATURE MUST BE VERIFIED ON ANY ELECTRONIC COPIES.

ETM
Surveying & Mapping, Inc.
VISION • EXPERIENCE • RESULTS

14775 Old St. Augustine Road, Jacksonville, FL, 32258
Tel: (904) 642-8550 Fax: (904) 642-4165
Certificate of Authorization No.: LB 3624



Digital Signature
by: Bob L.
Pittman, P.S.M.

GENERAL NOTES:

- 1) THIS IS NOT A SURVEY.
- 2) BEARINGS BASED ON THE NORTHERLY LINE OF ALDEN TRACE UNIT THREE AS BEING SOUTH 89°57'25" WEST.

SCALE: 1"=200'

DATE: OCTOBER 26, 2023

BOB L. PITTMAN
PROFESSIONAL SURVEYOR AND MAPPER
STATE OF FLORIDA PSM No. 4827

PROPERTIES
DUVAL MAPS

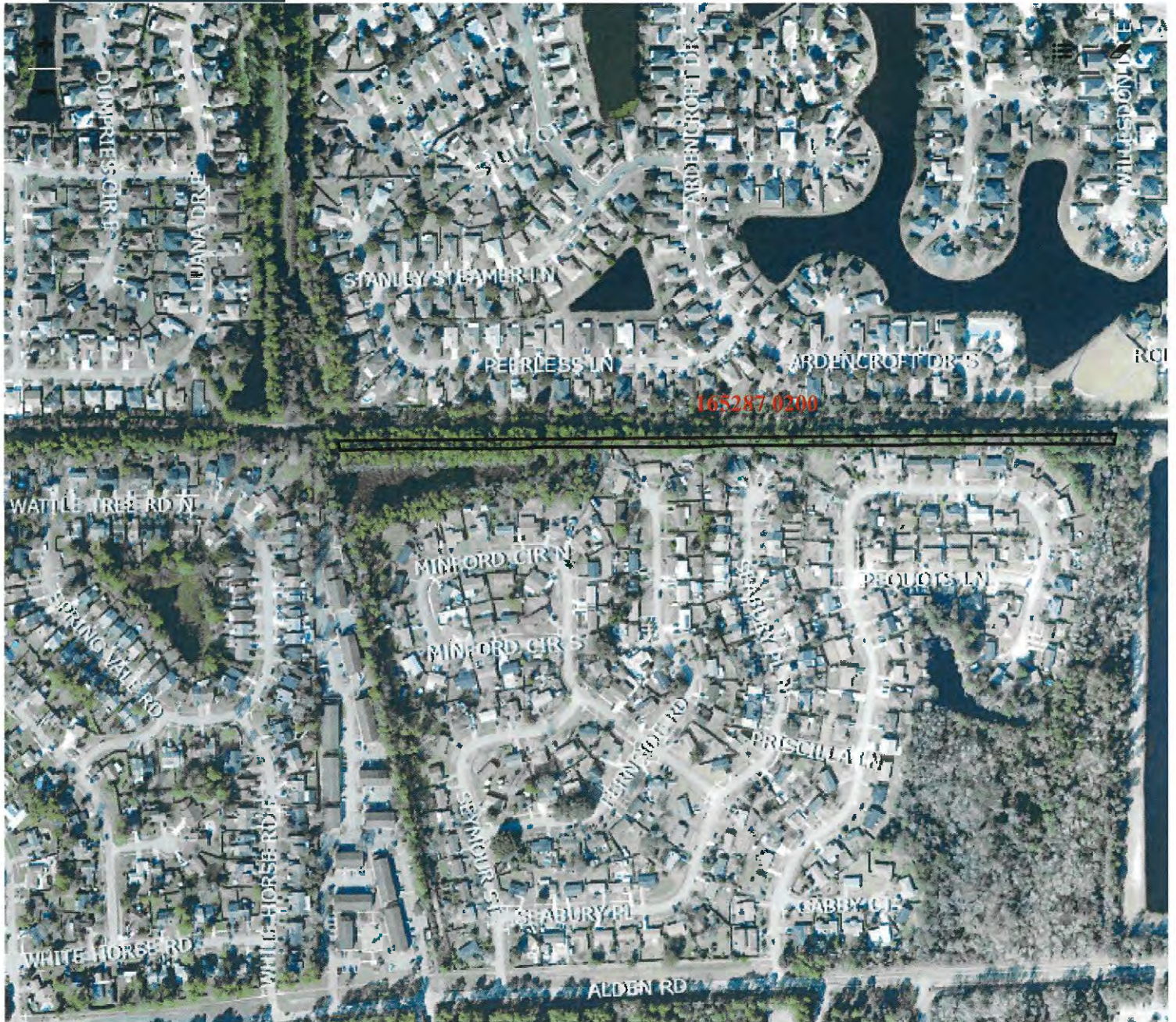

165287-0200



Mike Veazey

From: Mike Veazey
Sent: Tuesday, December 5, 2023 10:29 AM
To: Mike Veazey
Subject: Parcel 2





Sent from my iPhone

EXHIBIT 16

October 26, 2023

Work Order No. 22-164.04
File No. 128H-20.04C

CDD Transfer Parcel 3

A portion of Section 28, Township 2 South, Range 28 East, Duval County, Florida, being the same lands as Parcel B, as described and recorded in Official Records Book 16336, page 2390, of the current Public Records of said county, being more particularly described as follows:

For a Point of Beginning, commence at the Northwesterly corner of Richmond Place, as recorded in Plat Book 55, pages 82, 82A through 82B, of said current Public Records; thence South $07^{\circ}56'11''$ East, along the Westerly line of said Richmond Place, 126.19 feet to the Northwesterly corner of Tract "A", as depicted on said Richmond Place; thence South $89^{\circ}55'25''$ West, departing said Westerly line, 998.38 feet to the Northeasterly corner of Tract "A", as depicted on Coachman Meadows Unit Two, recorded in Plat 55, pages 3 and 3A, of said current Public Records; thence North $03^{\circ}03'49''$ East, along the Easterly line of said Coachman Meadows Unit Two, a distance of 125.19 feet to the Northeasterly corner thereof, said corner lying on the Southerly right of way line of that certain 40 foot Drainage right of way, as depicted on said Coachman Meadows Unit Two and said Richmond Place; thence North $89^{\circ}55'25''$ East, departing said Easterly line and along said Southerly right of way line, 974.26 feet to the Point of Beginning.

Containing 2.83 acres, more or less.

**SKETCH TO ACCOMPANY DESCRIPTION OF
A PORTION OF SECTION 28, TOWNSHIP 2 SOUTH, RANGE 28 EAST,
DUVAL COUNTY, FLORIDA, BEING THE SAME LANDS AS PARCEL B,
AS DESCRIBED AND RECORDED IN OFFICIAL RECORDS BOOK 16336,
PAGE 2390, OF THE CURRENT PUBLIC RECORDS OF SAID COUNTY,
BEING MORE PARTICULARLY DESCRIBED IN SEPARATE ATTACHMENT.**

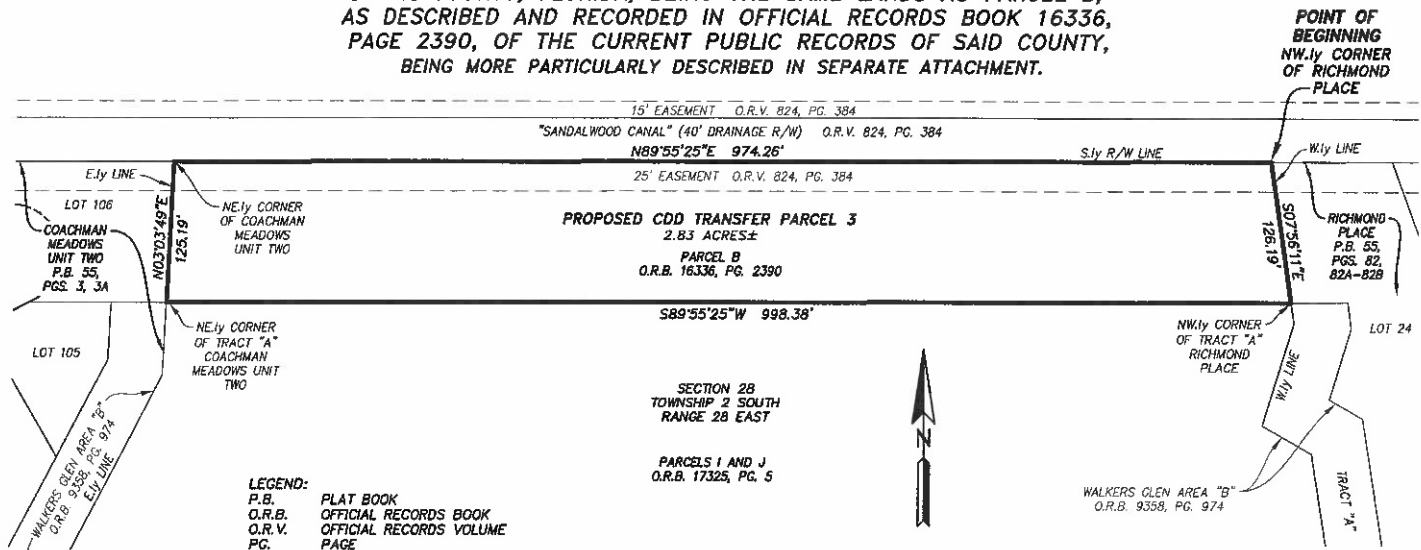

LEGEND:
P.B. PLAT BOOK
O.R.B. OFFICIAL RECORDS BOOK
O.R.V. OFFICIAL RECORDS VOLUME
PG. PAGE
R/W RIGHT OF WAY

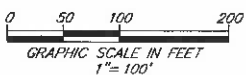

GENERAL NOTES:
1) THIS IS NOT A SURVEY.
2) BEARINGS BASED ON THE WESTERLY LINE OF RICHMOND PLACE AS BEING SOUTH $07^{\circ}56'11''$ EAST.

ETM
Surveying & Mapping, Inc.
VISION • EXPERIENCE • RESULTS

14775 Old St. Augustine Road, Jacksonville, FL 32258
Tel: (904) 642-8550 Fax: (904) 642-4165
Certificate of Authorization No.: LB 3624

THIS ITEM HAS BEEN ELECTRONICALLY SIGNED AND SEALED USING A DIGITAL SIGNATURE. PRINTED COPIES OF THIS DOCUMENT ARE NOT CONSIDERED SIGNED AND SEALED AND THE SIGNATURE MUST BE VERIFIED ON ANY ELECTRONIC COPIES.



Digital Signature
by: Bob L. Pittman, P.S.M.

SCALE: 1"=100'
DATE: OCTOBER 26, 2023
BOB L. PITTMAN
PROFESSIONAL SURVEYOR AND MAPPER
STATE OF FLORIDA PSM No. 4827

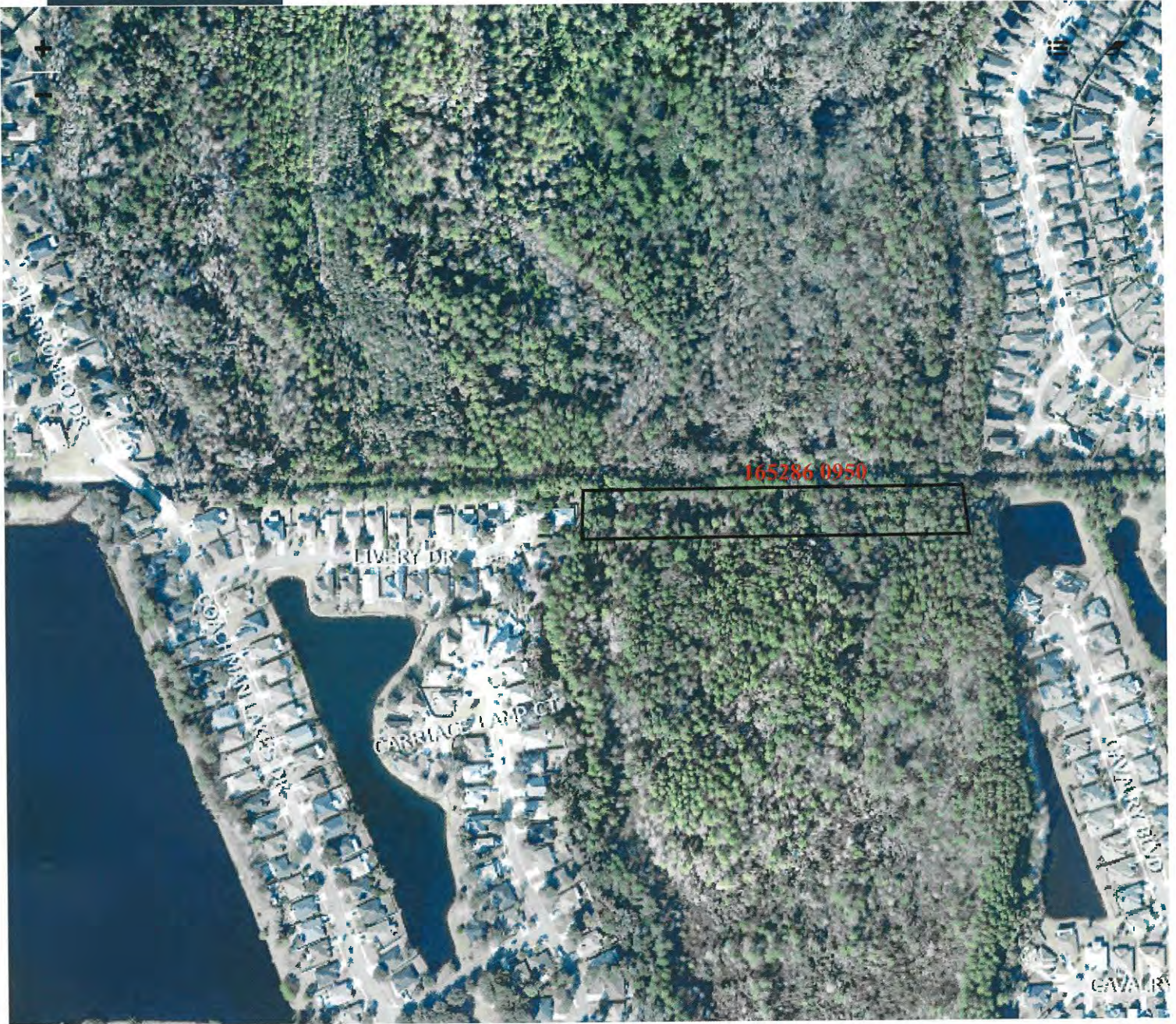

Mike Veazey

From: Mike Veazey
Sent: Tuesday, December 5, 2023 1:56 PM
To: Mike Veazey
Subject: Parcel 3



Sent from my iPhone

EXHIBIT 17

October 26, 2023

Work Order No. 22-164.04
File No. 128H-20.04D

CDD Transfer Parcel 4

A portion of Section 34, Township 2 South, Range 28 East, Duval County, Florida, being a portion of Parcel A, as described and recorded in Official Records Book 16339, page 1146, of the current Public Records of said county, being more particularly described as follows:

For a Point of Reference, commence at the Westerly corner of the Southerly terminus of Tamaya Boulevard, a variable width right of way, as depicted on Tamaya Boulevard Phase 1, recorded in Plat Book 70, pages 37 through 42, of said current Public Records, said corner lying on the Northerly right of way line of Beach Boulevard (U.S. Highway No. 90) (State Road No. 212), a 200 foot right of way as presently established; thence South $89^{\circ}30'13''$ West, along said Northerly right of way line, 23.54 feet to the Southwesterly corner of those lands described and recorded in Official Records Book 14868, page 1172, of said current Public Records and the Point of Beginning.

From said Point of Beginning, thence continue South $89^{\circ}30'13''$ West, along said Northerly right of way line, 176.24 feet to a point lying on the boundary line of those lands described and recorded in Official Records Book 20015, page 1227, of said current Public Records; thence along said boundary line the following 4 courses: Course 1, thence North $00^{\circ}31'50''$ West, departing said Northerly right of way line, 49.57 feet; Course 2, thence Due East, 156.32 feet; Course 3, thence North $00^{\circ}03'12''$ East, 180.58 feet; Course 4, thence North $88^{\circ}43'46''$ East, 41.95 feet to a point lying on the Westerly right of way line of said Tamaya Boulevard; thence South $00^{\circ}26'58''$ East, departing said boundary line and along said Westerly right of way line, 29.35 feet to the Northeasterly corner of those lands described and recorded in said Official Records Book 14868, page 1172; thence South $89^{\circ}30'13''$ West, departing said Westerly right of way line and along the boundary line of last said lands, 23.60 feet; thence South $00^{\circ}28'01''$ East, continuing along said boundary line, 200.00 feet to the Point of Beginning.

Containing 12,755 square feet, more or less.

**SKETCH TO ACCOMPANY DESCRIPTION OF
A PORTION OF SECTION 34, TOWNSHIP 2 SOUTH, RANGE 28 EAST,
DUVAL COUNTY, FLORIDA, BEING A PORTION OF PARCEL A,
AS DESCRIBED AND RECORDED IN OFFICIAL RECORDS BOOK 16339,
PAGE 1146, OF THE CURRENT PUBLIC RECORDS OF SAID COUNTY,
BEING MORE PARTICULARLY DESCRIBED IN SEPARATE ATTACHMENT.**

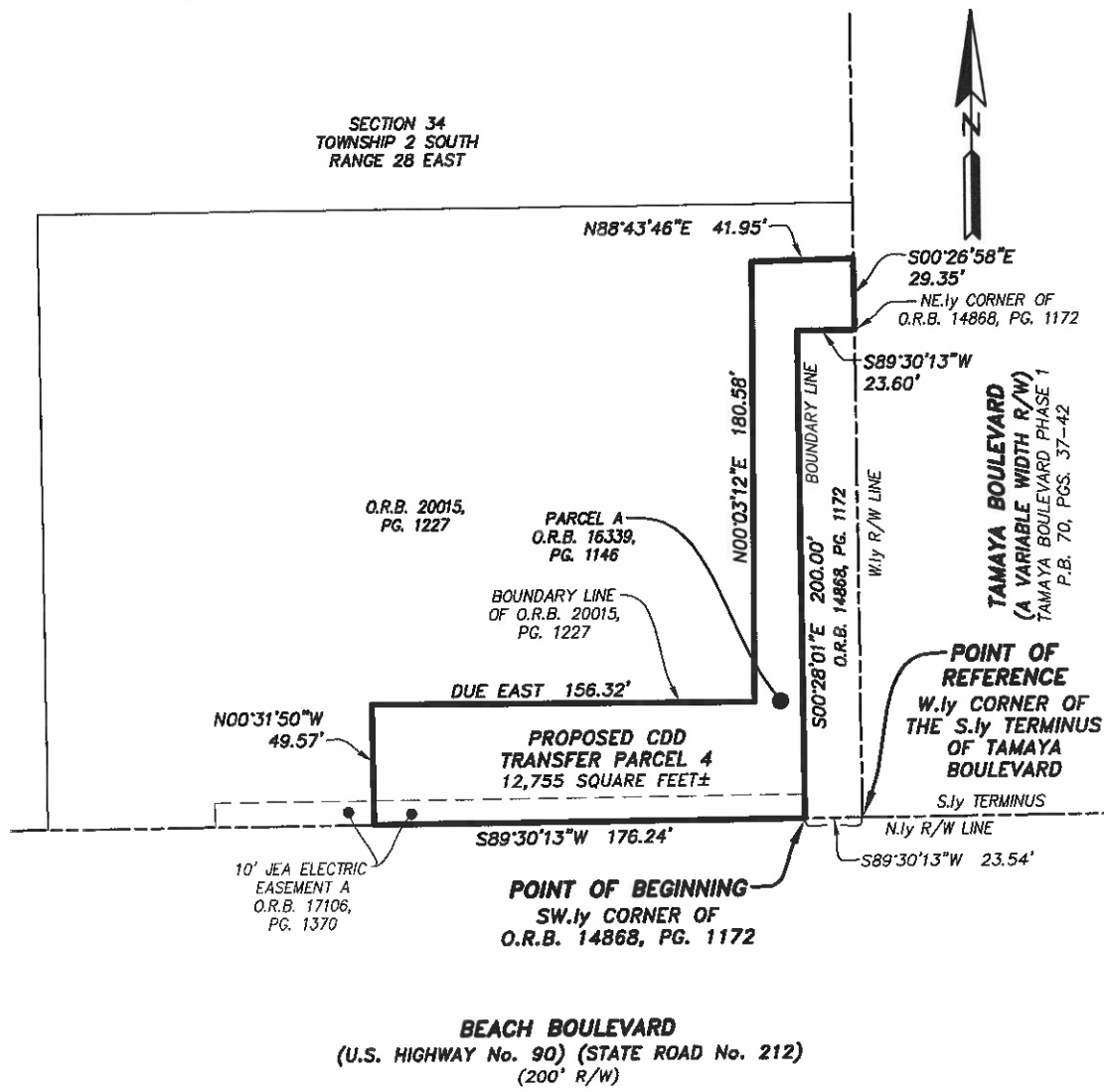

LEGEND:
P.B. PLAT BOOK
O.R.B. OFFICIAL RECORDS BOOK
PG. PAGE
R/W RIGHT OF WAY

GENERAL NOTES:
1) THIS IS NOT A SURVEY.
2) BEARINGS BASED ON THE NORTHERLY RIGHT OF WAY LINE
OF BEACH BOULEVARD AS BEING SOUTH 89°30'13" WEST.

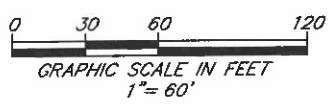

ETM
Surveying & Mapping, Inc.
VISION • EXPERIENCE • RESULTS

14775 Old St. Augustine Road, Jacksonville, FL. 32258
Tel: (904) 642-8550 Fax: (904) 642-4165
Certificate of Authorization No.: LB 3624

THIS ITEM HAS BEEN ELECTRONICALLY SIGNED AND SEALED
USING A DIGITAL SIGNATURE. PRINTED COPIES OF THIS
DOCUMENT ARE NOT CONSIDERED SIGNED AND SEALED AND THE
SIGNATURE MUST BE VERIFIED ON ANY ELECTRONIC COPIES.



Digital Signature
by: Bob L.
Pittman, P.S.M.

SCALE: 1"=60'
DATE: OCTOBER 26, 2023
BOB L. PITTMAN
PROFESSIONAL SURVEYOR AND MAPPER
STATE OF FLORIDA PSM No. 4827

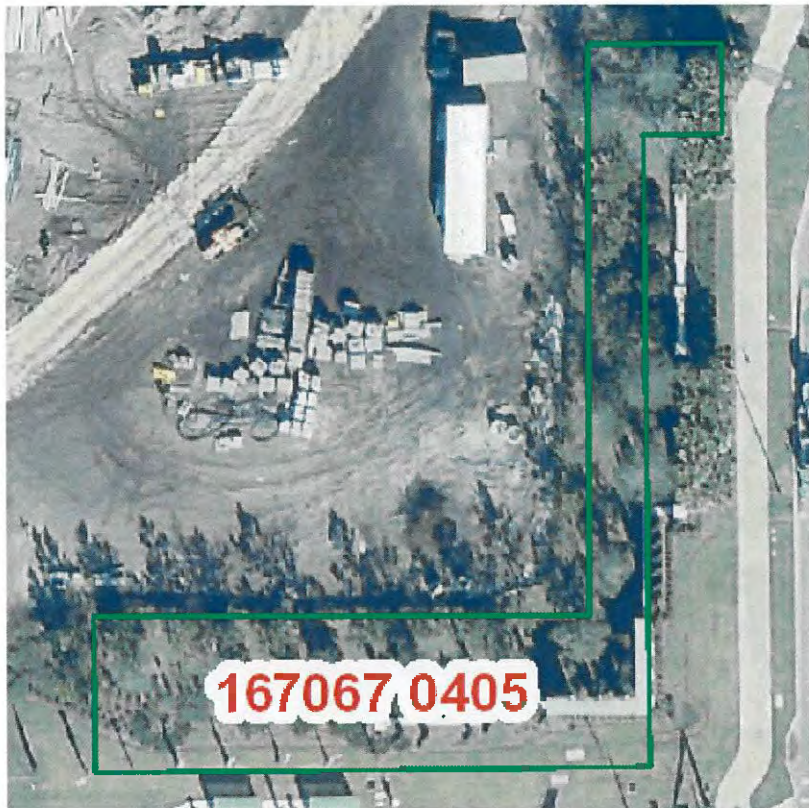

Mike Veazey

From: Mike Veazey
Sent: Thursday, December 7, 2023 4:48 PM
To: Mike Veazey
Subject: TAMAYA Beach Entrance



Sent from my iPhone

Mike Veazey

From: Mike Veazey
Sent: Thursday, December 7, 2023 4:37 PM
To: Mike Veazey
Subject: TAMAYA Beach Entrance



Sent from my iPhone

EXHIBIT 18

October 26, 2023

Work Order No. 22-164.04
File No. 128H-20.04E

CDD Transfer Parcel 5

A portion of Section 34, Township 2 South, Range 28 East, Duval County, Florida, being a portion of Parcel A, as described and recorded in Official Records Book 16339, page 1146, of the current Public Records of said county, being more particularly described as follows:

For a Point of Reference, commence at the Northeasterly corner of Redhawk Village, as recorded in Plat Book 73, pages 112 through 122, of said current Public Records, said corner lying on the Westerly right of way line of Tamaya Boulevard, a variable width right of way as presently established; thence Northerly along said Westerly right of way line the following 4 courses: Course 1, thence North $12^{\circ}47'05''$ East, 110.99 feet; Course 2, thence North $77^{\circ}12'55''$ West, 4.50 feet; Course 3, thence North $12^{\circ}47'05''$ East, 62.75 feet to the point of curvature of a curve concave Westerly having a radius of 599.00 feet; Course 4, thence Northerly along the arc of said curve, through a central angle of $12^{\circ}24'02''$, an arc length of 129.64 feet to a point lying on the boundary line of those lands described and recorded in Official Records Book 17503, page 2316, of said current Public Records and the Point of Beginning, said arc being subtended by a chord bearing and distance of North $06^{\circ}35'04''$ East, 129.39 feet.

From said Point of Beginning, thence along said boundary line the following 5 courses: Course 1, thence South $89^{\circ}03'04''$ West, departing said Westerly right of way line and along a non-tangent line, 20.01 feet to a point on a non-tangent curve concave Westerly having a radius of 579.00 feet; Course 2, thence Northerly along the arc of said curve, through a central angle of $09^{\circ}57'22''$, an arc length of 100.61 feet to a point on said curve, said arc being subtended by a chord bearing and distance of North $04^{\circ}32'52''$ West, 100.49 feet; Course 3, thence Northerly along the arc of a non-tangent curve concave Easterly having a radius of 131.79 feet, through a central angle of $77^{\circ}36'33''$, an arc length of 178.52 feet to a point on said curve, said arc being subtended by a chord bearing and distance of North $17^{\circ}43'36''$ West, 165.18 feet; Course 4, thence Northwesterly along the arc of a non-tangent curve concave Southwesterly having a radius of 579.00 feet, through a central angle of $09^{\circ}45'46''$, an arc length of 98.66 feet to a point on said curve, said arc being subtended by a chord bearing and distance of North $30^{\circ}48'33''$ West, 98.54 feet; Course 5, thence North $54^{\circ}56'12''$ East, along a non-tangent line, 20.00 feet to a point lying on said Westerly right of way line of Tamaya Boulevard; thence Southerly departing said boundary line, along said Westerly right of way line, and along the arc of a non-tangent curve concave Westerly having a radius of 599.00 feet, through a central angle of $36^{\circ}03'14''$, an arc length of 376.93 feet to the Point of Beginning, said arc being subtended by a chord bearing and distance of South $17^{\circ}38'34''$ East, 370.74 feet.

Containing 11,354 square feet, more or less.

**SKETCH TO ACCOMPANY DESCRIPTION OF
A PORTION OF SECTION 34, TOWNSHIP 2 SOUTH, RANGE 28 EAST,
DUVAL COUNTY, FLORIDA, BEING A PORTION OF PARCEL A,
AS DESCRIBED AND RECORDED IN OFFICIAL RECORDS BOOK 16339,
PAGE 1146, OF THE CURRENT PUBLIC RECORDS OF SAID COUNTY,
BEING MORE PARTICULARLY DESCRIBED IN SEPARATE ATTACHMENT.**

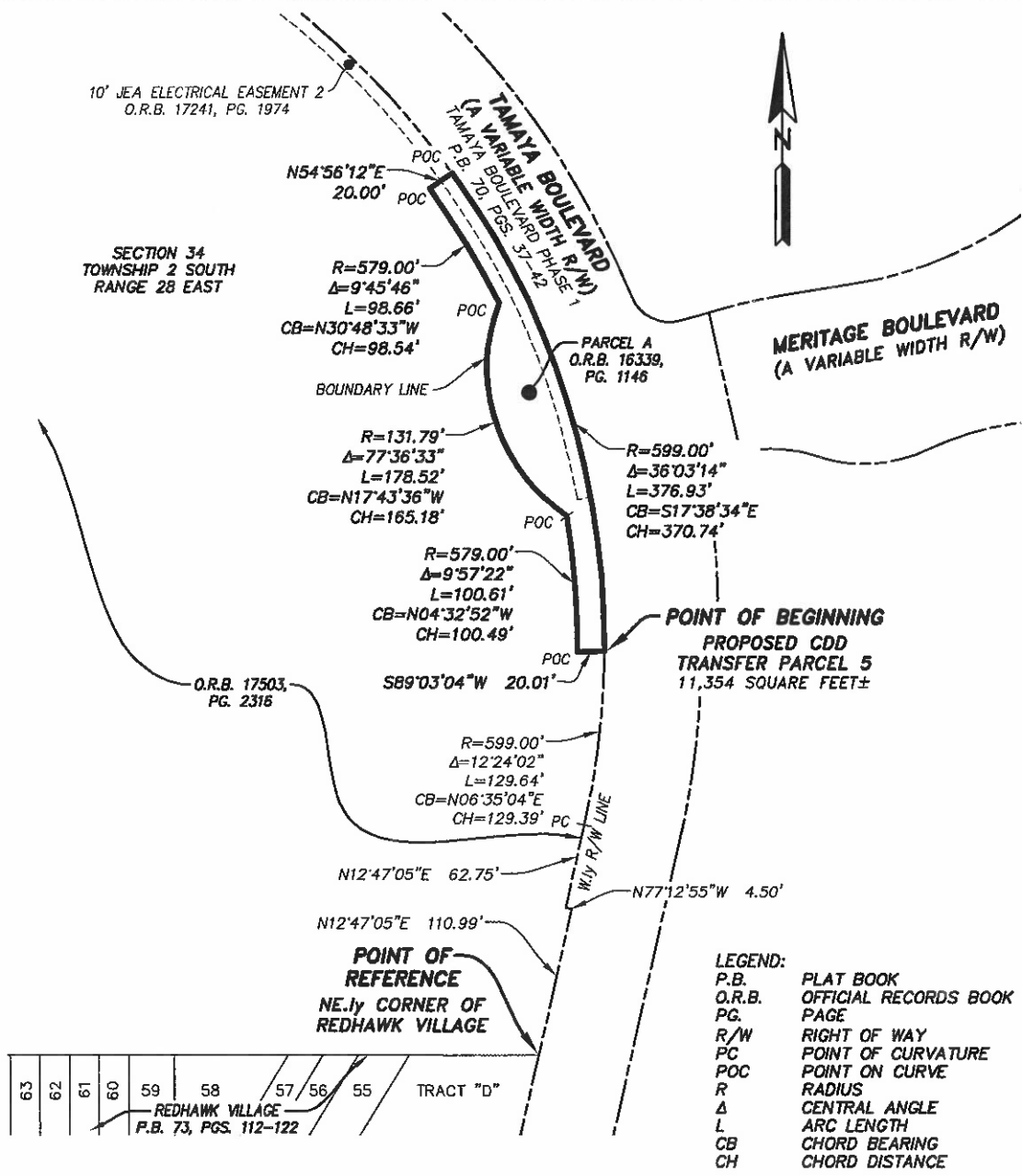

GENERAL NOTES:
1) THIS IS NOT A SURVEY.
2) BEARINGS BASED ON THE WESTERLY RIGHT OF WAY LINE OF TAMAYA BOULEVARD AS BEING NORTH 12°47'05" EAST.

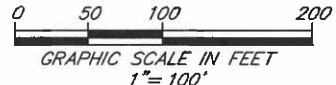

ETM
Surveying & Mapping, Inc.
VISION • EXPERIENCE • RESULTS

14775 Old St. Augustine Road, Jacksonville, FL 32258
Tel: (904) 642-8550 Fax: (904) 642-4165
Certificate of Authorization No.: LB 3624

THIS ITEM HAS BEEN ELECTRONICALLY SIGNED AND SEALED USING A DIGITAL SIGNATURE. PRINTED COPIES OF THIS DOCUMENT ARE NOT CONSIDERED SIGNED AND SEALED AND THE SIGNATURE MUST BE VERIFIED ON ANY ELECTRONIC COPIES.



Digital Signature
by: Bob L.
Pittman, P.S.M.

SCALE: 1"=100'
DATE: OCTOBER 26, 2023
BOB L. PITTMAN
PROFESSIONAL SURVEYOR AND MAPPER
STATE OF FLORIDA PSM No. 4827

PROPERTIES
DUVAL MAPS

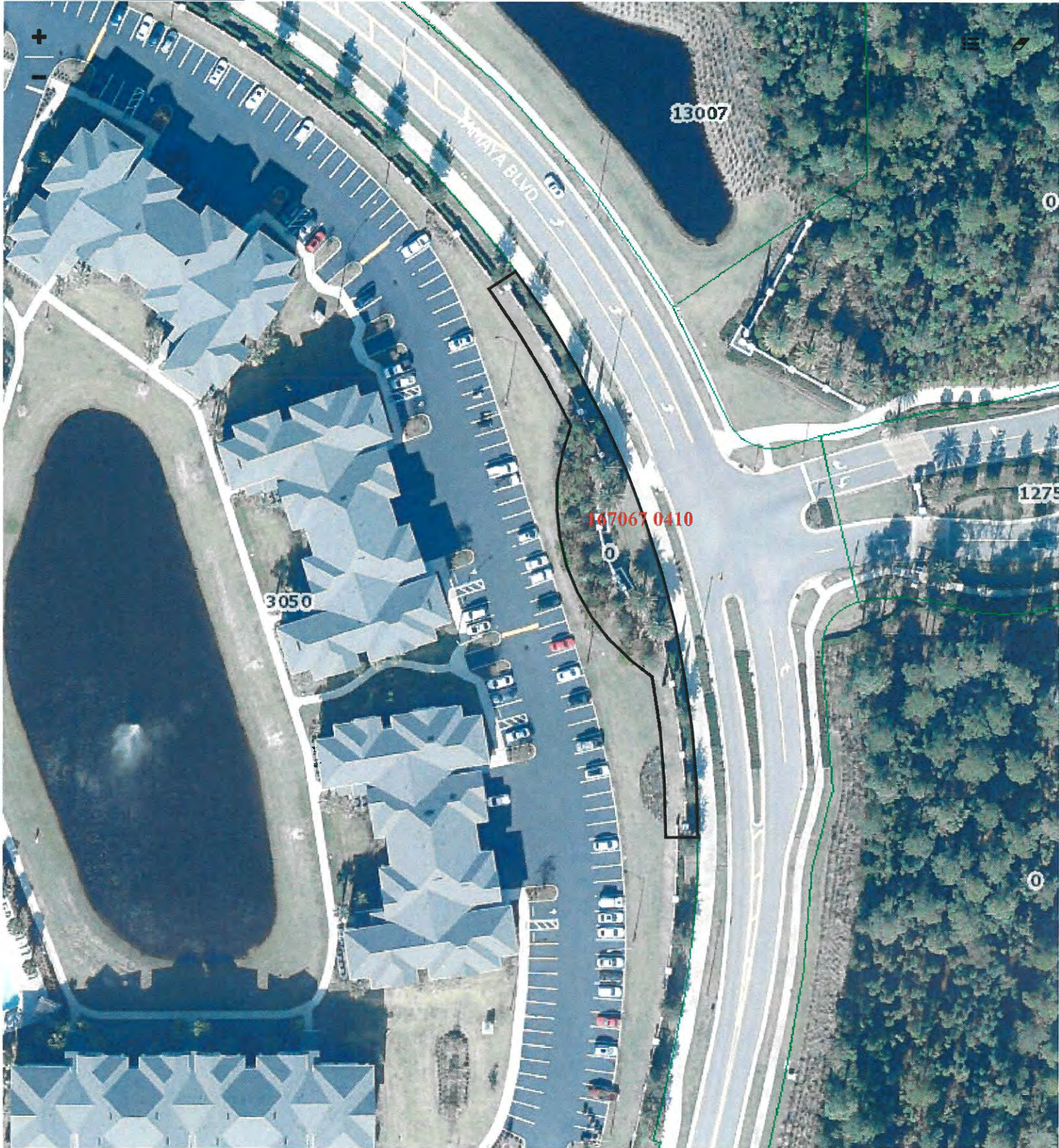

Mike Veazey

From: Mike Veazey
Sent: Thursday, December 7, 2023 4:38 PM
To: Mike Veazey
Subject: TAMAYA Exit Parcel



Sent from my iPhone

EXHIBIT 19

Revised December 8, 2023
October 10, 2023
Page 1 of 2

Work Order No. 22-164.03
File No. 128H-20.03A

CDD Transfer Parcel 6

A portion of Section 34, Township 2 South, Range 28 East, Duval County, Florida, being a portion of Parcel A, as described and recorded in Official Records Book 16339, page 1146, of the current Public Records of said county, being more particularly described as follows:

For a Point of Beginning, commence at the Southwesterly corner of Liv at Tamaya, as recorded in Plat Book 80, pages 79 through 95, of said current Public Records, said corner lying on the Northerly right of way line of Beach Boulevard (U.S. Highway No. 90) (State Road No. 212), a 200 foot right of way as presently established; thence South $89^{\circ}30'13''$ West, along said Northerly right of way line, 412.08 feet to the Southeasterly corner of those lands described and recorded in Official Records Book 14868, page 1172, of said current Public Records; thence North $00^{\circ}30'02''$ West, departing said Northerly right of way line and along the boundary line of last said lands, 200.00 feet; thence South $89^{\circ}30'13''$ West, continuing along said boundary line, 34.18 feet to the Northwesterly corner thereof, said corner lying on the Easterly right of way line of Tamaya Boulevard, a variable width right of way as presently established; thence North $00^{\circ}26'58''$ West, departing said boundary line and along said Easterly right of way line, 215.27 feet to the Southwesterly corner of those lands described and recorded in Official Records Book 14999, page 470, of said current Public Records; thence along the boundary line of last said lands the following 10 courses: Course 1, thence Due East, departing said Easterly right of way line, 33.86 feet; Course 2, thence North $89^{\circ}59'53''$ East, 121.68 feet to the point of curvature of a curve concave Northwesterly having a radius of 51.50 feet; Course 3, thence Northeasterly along the arc of said curve, through a central angle of $89^{\circ}59'53''$, an arc length of 80.89 feet to the point of tangency of said curve, said arc being subtended by a chord bearing and distance of North $44^{\circ}59'56''$ East, 72.83 feet; Course 4, thence Due North, 209.02 feet; Course 5, thence North $03^{\circ}32'23''$ East, 28.99 feet; Course 6, thence North $14^{\circ}58'32''$ West, 44.10 feet; Course 7, thence North $73^{\circ}30'09''$ West, 37.61 feet; Course 8, thence North $46^{\circ}04'25''$ West, 80.24 feet; Course 9, thence North $62^{\circ}26'52''$ West, 42.68 feet; Course 10, thence South $89^{\circ}33'02''$ West, 69.02 feet to the Northwesterly corner thereof, said corner lying on said Easterly right of way line of Tamaya Boulevard; thence along said Easterly right of way line the following 8 courses: Course 1, thence North $00^{\circ}26'58''$ West, departing said boundary line, 186.12 feet to the point of curvature of a curve concave Easterly having a radius of 2230.00 feet; Course 2, thence Northerly along the arc of said curve, through a central angle of $13^{\circ}14'03''$, an arc length of 515.09 feet to the point of tangency of said curve, said arc being subtended by a chord bearing and distance of North $06^{\circ}10'04''$ East, 513.94 feet; Course 3, thence North $12^{\circ}47'05''$ East, 444.45 feet to the point of curvature of a curve concave Westerly having a radius of 670.50 feet; Course 4, thence Northerly along the arc of said curve, through a

Revised December 8, 2023

October 10, 2023

Page 2 of 2

Work Order No. 22-164.03

File No. 128H-20.03A

CDD Transfer Parcel 6 (continued)

central angle of $10^{\circ}43'04''$, an arc length of 125.43 feet to a point on said curve, said arc being subtended by a chord bearing and distance of North $07^{\circ}25'33''$ East, 125.24 feet; Course 5, thence North $14^{\circ}41'37''$ East, along a non-tangent line, 51.72 feet to a point on a non-tangent curve concave Westerly having a radius of 679.50 feet; Course 6, thence Northerly along the arc of said curve, through a central angle of $07^{\circ}05'00''$, an arc length of 84.00 feet to a point of reverse curvature, said arc being subtended by a chord bearing and distance of North $04^{\circ}24'06''$ West, 83.95 feet; Course 7, thence Northeasterly along the arc of a curve concave Southeasterly having a radius of 30.00 feet, through a central angle of $84^{\circ}03'59''$, an arc length of 44.02 feet to a point of compound curvature, said point being the Southerly corner of the Westerly terminus of Meritage Boulevard, a variable width right of way, as depicted on Bella Nina at Tamaya Phase 2, recorded in Plat Book 69, pages 27 through 32, of said current Public Records, said arc being subtended by a chord bearing and distance of North $34^{\circ}05'24''$ East, 40.17 feet; thence Easterly along the Southerly right of way line of said Meritage Boulevard the following 3 courses: Course 1, thence Easterly along the arc of a curve concave Southerly having a radius of 100.00 feet, through a central angle of $32^{\circ}37'30''$, an arc length of 56.94 feet to a point of reverse curvature, said arc being subtended by a chord bearing and distance of South $87^{\circ}33'52''$ East, 56.18 feet; Course 2, thence Easterly along the arc of a curve concave Northerly having a radius of 108.00 feet, through a central angle of $44^{\circ}50'09''$, an arc length of 84.51 feet to a point of reverse curvature, said arc being subtended by a chord bearing and distance of North $86^{\circ}19'49''$ East, 82.37 feet; Course 3, thence Easterly along the arc of a curve concave Southerly having a radius of 207.00 feet, through a central angle of $22^{\circ}31'03''$, an arc length of 81.35 feet to a point on said curve, said point being the Northwesterly corner of said Liv at Tamaya, said arc being subtended by a chord bearing and distance of North $75^{\circ}10'16''$ East, 80.83 feet; thence along the Westerly line of said Liv at Tamaya the following 3 courses: Course 1, thence Due South, departing said Southerly right of way line and along a non-tangent line, 746.46 feet; Course 2, thence South $06^{\circ}23'49''$ East, 350.00 feet; Course 3, thence Due South, 1180.00 feet to the Point of Beginning.

Containing 18.24 acres, more or less.

SKETCH TO ACCOMPANY DESCRIPTION OF

A PORTION OF SECTION 34, TOWNSHIP 2 SOUTH, RANGE 28 EAST,
 DUVAL COUNTY, FLORIDA, BEING A PORTION OF PARCEL A,
 AS DESCRIBED AND RECORDED IN OFFICIAL RECORDS BOOK 16339,
 PAGE 1146, OF THE CURRENT PUBLIC RECORDS OF SAID COUNTY,
 BEING MORE PARTICULARLY DESCRIBED IN SEPARATE ATTACHMENT.

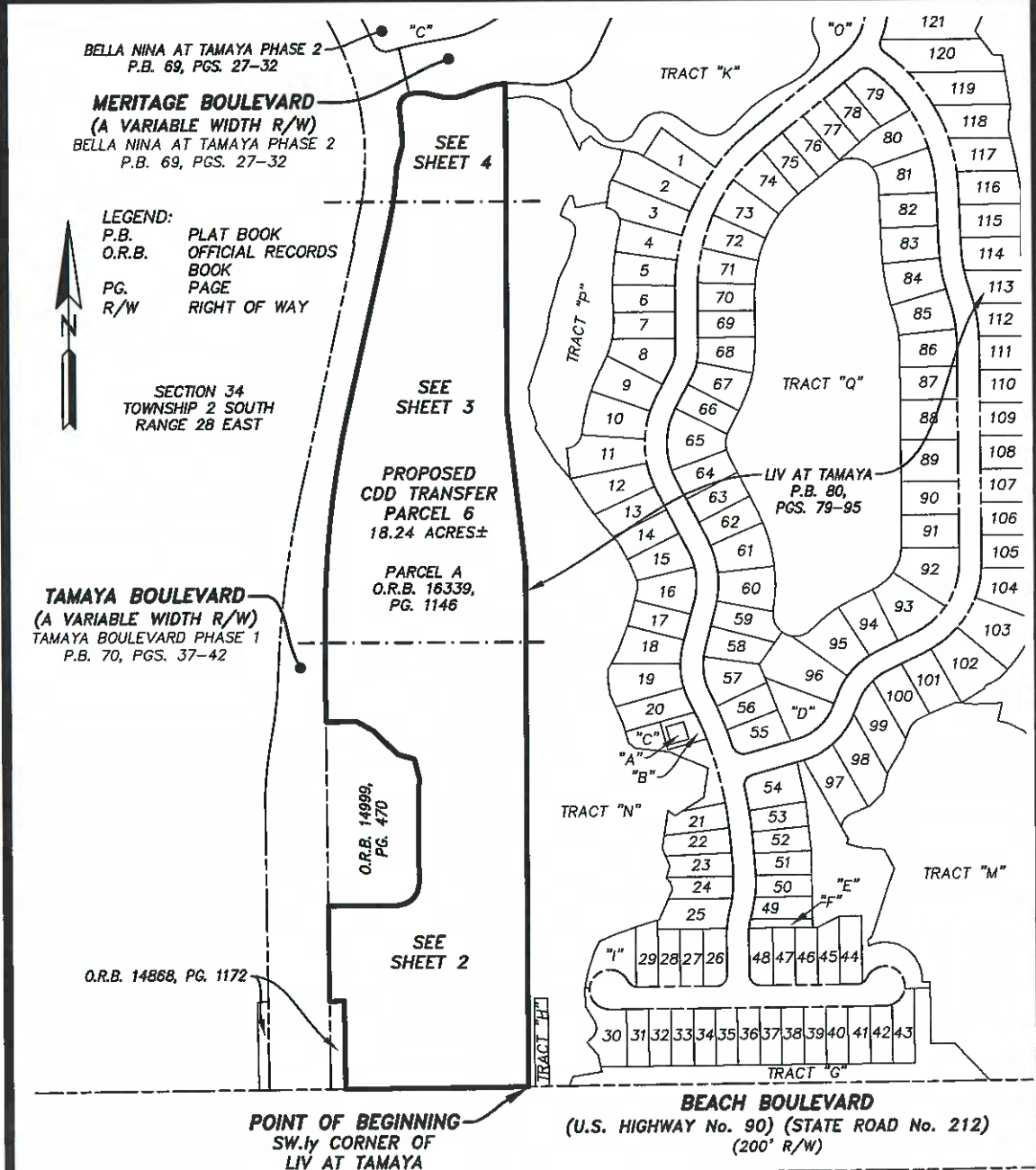

SHEET 1 OF 4
 GENERAL NOTES:
 1) THIS IS NOT A SURVEY.
 2) BEARINGS BASED ON THE NORTHERLY RIGHT OF WAY LINE
 OF BEACH BOULEVARD AS BEING SOUTH 89°30'13" WEST.

REVISED PARCEL NUMBER; DECEMBER 8, 2023

0 150 300 600
 GRAPHIC SCALE IN FEET
 1" = 300'



14775 Old St. Augustine Road, Jacksonville, FL 32258
 Tel: (904) 642-8550 Fax: (904) 642-4165
 Certificate of Authorization No.: LB 3624

THIS ITEM HAS BEEN ELECTRONICALLY SIGNED AND SEALED
 USING A DIGITAL SIGNATURE. PRINTED COPIES OF THIS
 DOCUMENT ARE NOT CONSIDERED SIGNED AND SEALED AND THE
 SIGNATURE MUST BE VERIFIED ON ANY ELECTRONIC COPIES.



Digital Signature
 by: Bob L.
 Pittman, P.S.M.

SCALE: 1"=300'
 DATE: OCTOBER 10, 2023
BOB L. PITTMAN
 PROFESSIONAL SURVEYOR AND MAPPER
 STATE OF FLORIDA PSM No. 4827

A PORTION OF SECTION 34, TOWNSHIP 2 SOUTH, RANGE 28 EAST,
 DUVAL COUNTY, FLORIDA, BEING A PORTION OF PARCEL A,
 AS DESCRIBED AND RECORDED IN OFFICIAL RECORDS BOOK 16339,
 PAGE 1146, OF THE CURRENT PUBLIC RECORDS OF SAID COUNTY.

MATCHLINE SEE SHEET 3

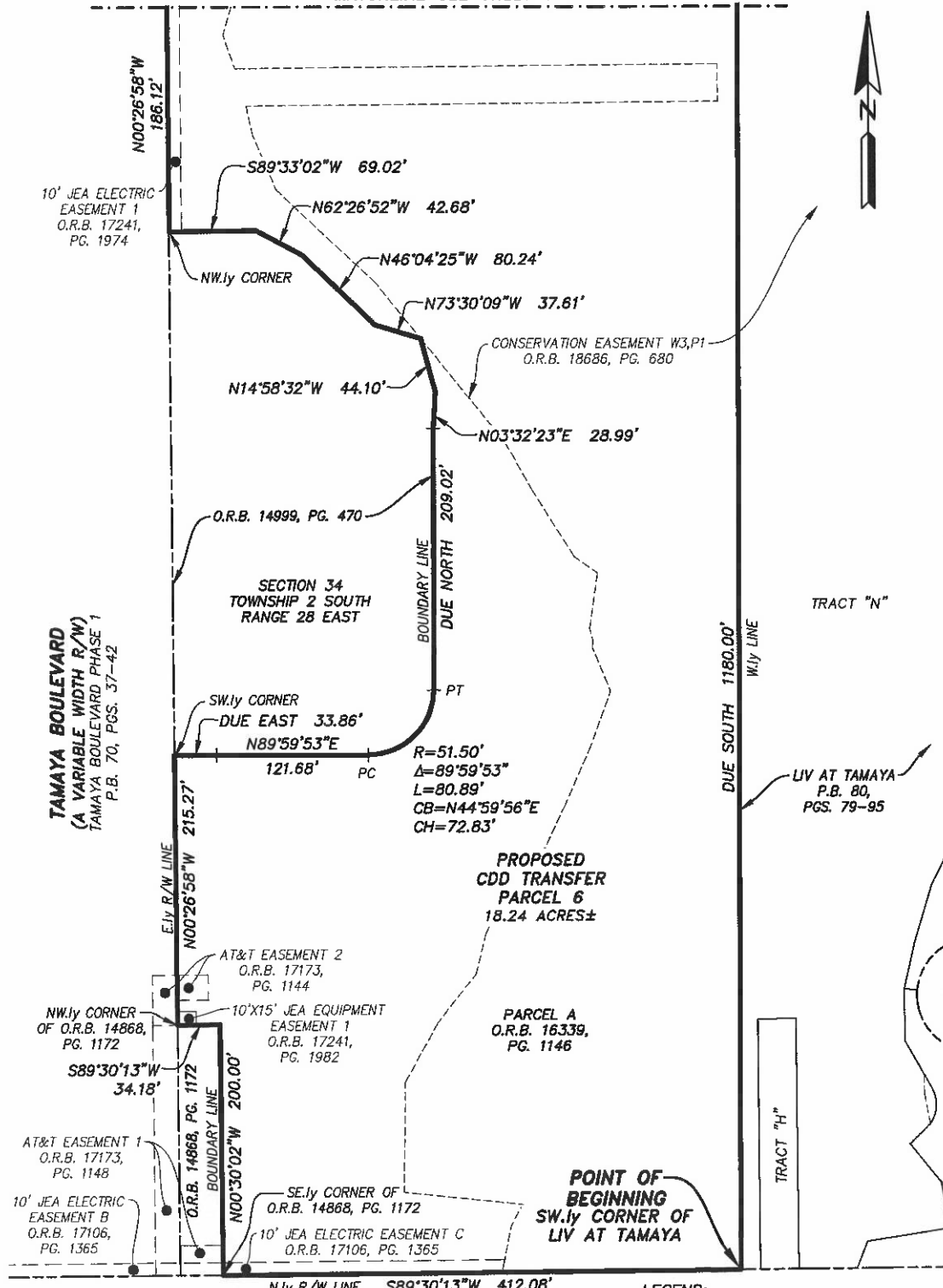

TAMAYA BOULEVARD
 (A VARIABLE WIDTH R/W)
 TAMAYA BOULEVARD PHASE 1
 P.B. 70, PGS. 37-42

BEACH BOULEVARD
 (U.S. HIGHWAY No. 90)
 (STATE ROAD No. 212)
 (200' R/W)

SHEET 2 OF 4
 SEE SHEET 1 FOR GENERAL NOTES.

PREPARED BY:
ETM SURVEYING & MAPPING, INC.
 14775 OLD ST. AUGUSTINE ROAD
 JACKSONVILLE, FL 32258 (904) 642-8550
 CERTIFICATE OF AUTHORIZATION NO. LB 3624

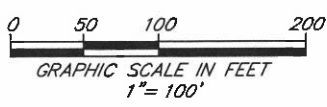

LEGEND:

P.B.	PLAT BOOK
O.R.B.	OFFICIAL RECORDS BOOK
O.R.V.	OFFICIAL RECORDS VOLUME
PG.	PAGE
R/W	RIGHT OF WAY
PC	POINT OF CURVATURE
PT	POINT OF TANGENCY
R	RADIUS
Δ	CENTRAL ANGLE
L	ARC LENGTH
CB	CHORD BEARING
CH	CHORD DISTANCE

A PORTION OF SECTION 34, TOWNSHIP 2 SOUTH, RANGE 28 EAST,
 DUVAL COUNTY, FLORIDA, BEING A PORTION OF PARCEL A,
 AS DESCRIBED AND RECORDED IN OFFICIAL RECORDS BOOK 16339,
 PAGE 1146, OF THE CURRENT PUBLIC RECORDS OF SAID COUNTY.

MATCHLINE SEE SHEET 4

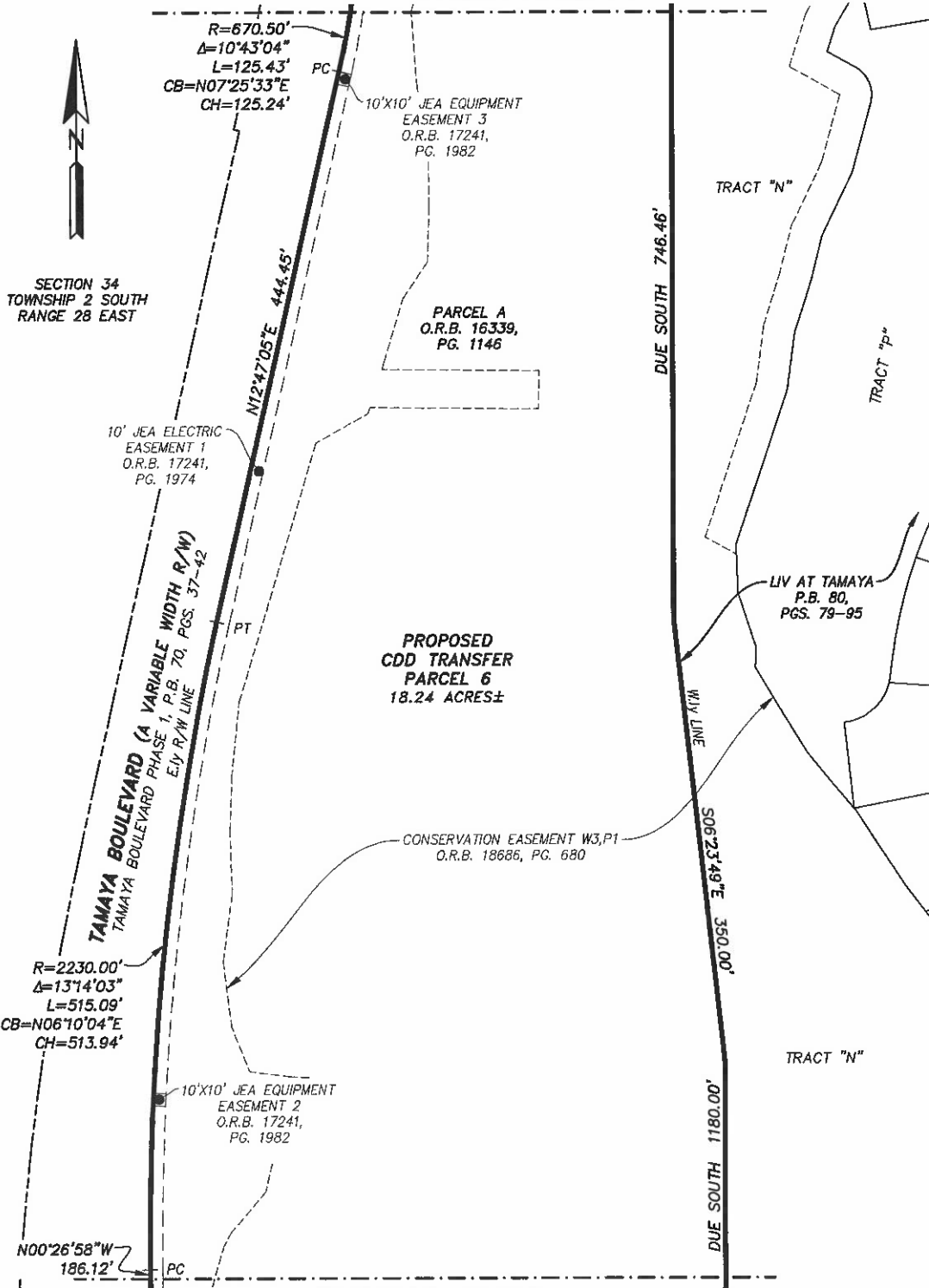

MATCHLINE SEE SHEET 2

- LEGEND:
- P.B. PLAT BOOK
 - O.R.B. OFFICIAL RECORDS BOOK
 - PG. PAGE
 - R/W RIGHT OF WAY
 - PC POINT OF CURVATURE
 - PT POINT OF TANGENCY
 - R RADIUS
 - Δ CENTRAL ANGLE
 - L ARC LENGTH
 - CB CHORD BEARING
 - CH CHORD DISTANCE

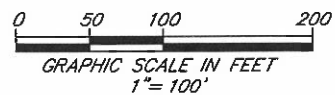

PREPARED BY:
 ETM SURVEYING & MAPPING, INC.
 14775 OLD ST. AUGUSTINE ROAD
 JACKSONVILLE, FL 32258 (904) 642-8550
 CERTIFICATE OF AUTHORIZATION NO. LB 3624

SHEET 3 OF 4
 SEE SHEET 1 FOR GENERAL NOTES.

A PORTION OF SECTION 34, TOWNSHIP 2 SOUTH, RANGE 28 EAST,
 DUVAL COUNTY, FLORIDA, BEING A PORTION OF PARCEL A,
 AS DESCRIBED AND RECORDED IN OFFICIAL RECORDS BOOK 16339,
 PAGE 1146, OF THE CURRENT PUBLIC RECORDS OF SAID COUNTY.

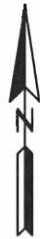

CURVE TABLE					
CURVE	RADIUS	CENTRAL ANGLE	ARC LENGTH	CHORD BEARING	CHORD DISTANCE
C1	670.50'	10°43'04"	125.43'	N07°25'33"E	125.24'
C2	679.50'	7°05'00"	84.00'	N04°24'06"W	83.95'
C3	30.00'	84°03'59"	44.02'	N34°05'24"E	40.17'
C4	100.00'	32°37'30"	56.94'	S87°33'52"E	56.18'
C5	108.00'	44°50'09"	84.51'	N86°19'49"E	82.37'
C6	207.00'	22°31'03"	81.35'	N75°10'16"E	80.83'

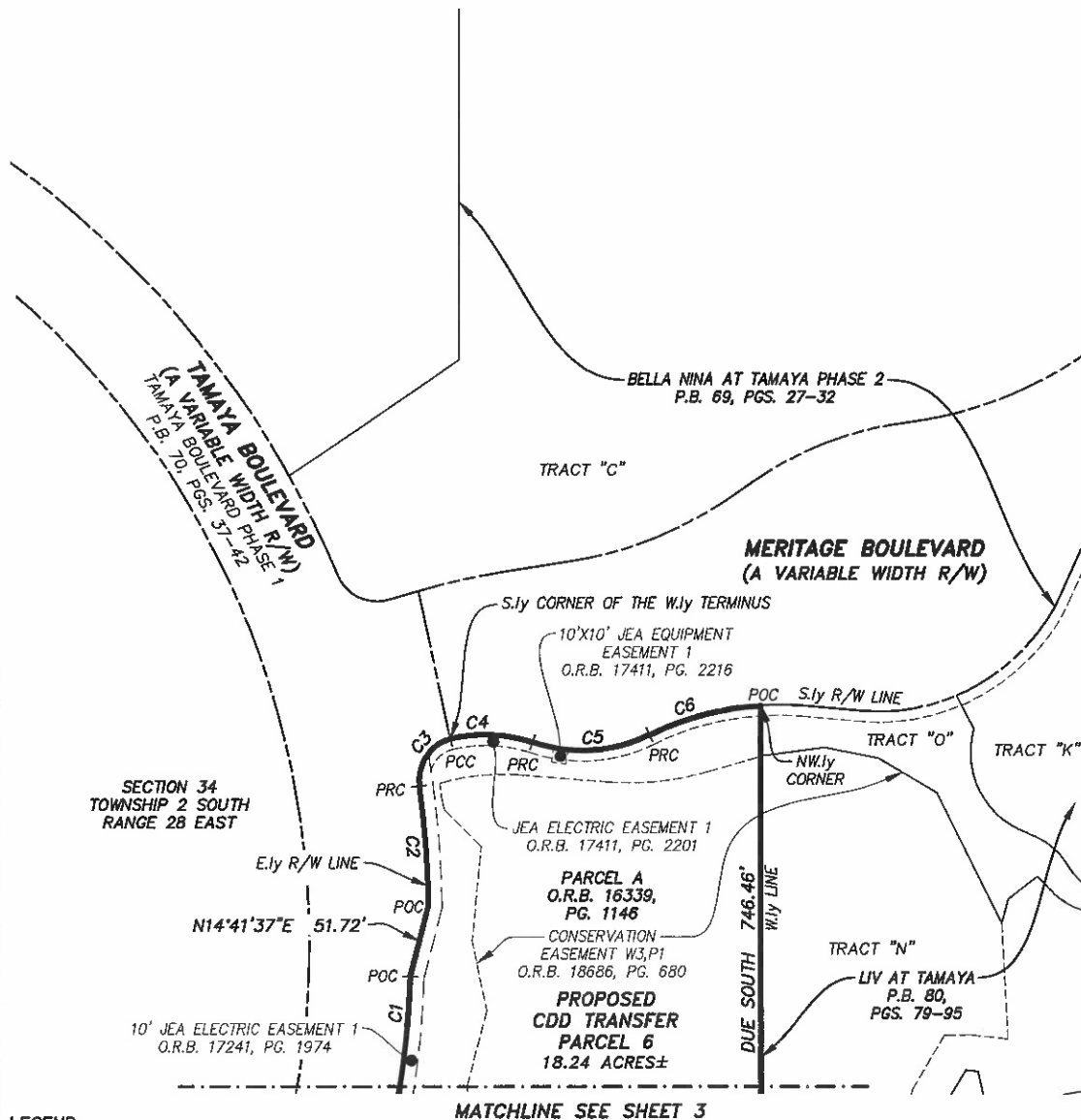

- LEGEND:**
- P.B. PLAT BOOK
 - O.R.B. OFFICIAL RECORDS BOOK
 - PG. PAGE
 - R/W RIGHT OF WAY
 - POC POINT ON CURVE
 - PRC POINT OF REVERSE CURVATURE
 - PCC POINT OF COMPOUND CURVATURE
 - C1 TABULATED CURVE DATA

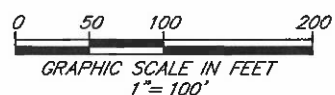

SHEET 4 OF 4
 SEE SHEET 1 FOR GENERAL NOTES.

PREPARED BY:
ETM SURVEYING & MAPPING, INC.
 14775 OLD ST. AUGUSTINE ROAD
 JACKSONVILLE, FL 32258 (904) 642-8550
 CERTIFICATE OF AUTHORIZATION NO. LB 3624

PROPERTIES
DUVAL MAPS

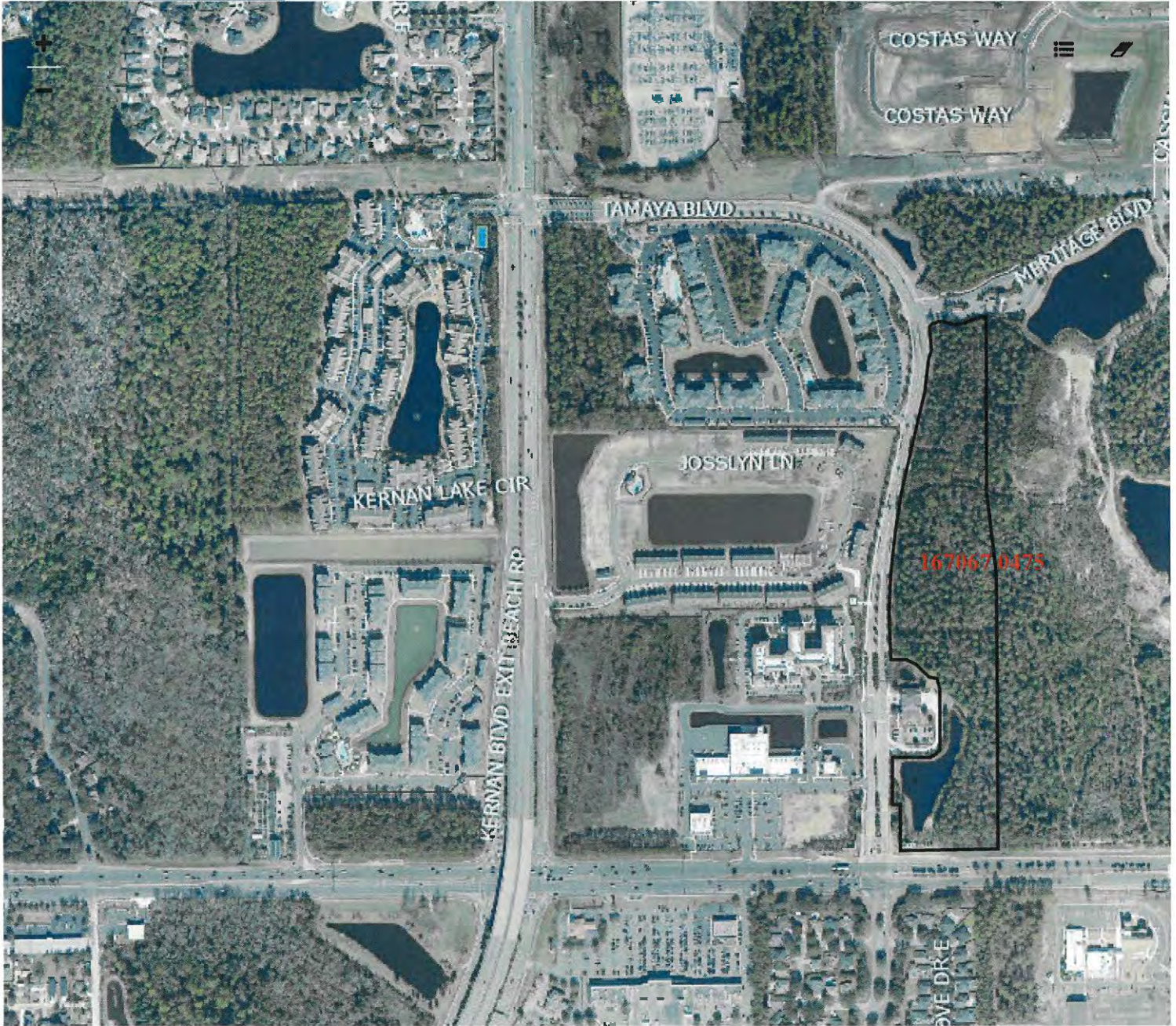

Mike Veazey

From: Mike Veazey
Sent: Thursday, December 7, 2023 4:38 PM
To: Mike Veazey
Subject: TAMAYA Conservation Tract







Sent from my iPhone

EXHIBIT 20

Revised December 8, 2023
October 10, 2023

Work Order No. 22-164.03
File No. 128H-20.03B

CDD Transfer Parcel 7

A portion of Section 34, Township 2 South, Range 28 East, Duval County, Florida, being a portion of Parcel A, as described and recorded in Official Records Book 16339, page 1146, of the current Public Records of said county, being more particularly described as follows:

For a Point of Beginning, commence at the Northwesterly corner of Bella Nina at Tamaya Phase 2, as recorded in Plat Book 69, pages 27 through 32, of said current Public Records; thence Due South, along the Westerly line of said Bella Nina at Tamaya Phase 2, a distance of 278.41 feet; thence South $55^{\circ}55'16''$ West, continuing along said Westerly line, 145.00 feet to the Westerly corner thereof, said corner lying on the Northerly right of way line of Tamaya Boulevard, a variable width right of way as presently established; thence Northwesterly along said Northerly right of way line the following 4 courses: Course 1, thence Northwesterly, departing said Westerly line and along the arc of a non-tangent curve concave Southwesterly having a radius of 670.50 feet, through a central angle of $60^{\circ}52'44''$, an arc length of 712.43 feet to the point of tangency of said curve, said arc being subtended by a chord bearing and distance of North $59^{\circ}41'12''$ West, 679.39 feet; Course 2, thence South $89^{\circ}52'26''$ West, 451.88 feet to the point of curvature of a curve concave Northerly having a radius of 300.00 feet; Course 3, thence Westerly along the arc of said curve, through a central angle of $18^{\circ}12'25''$, an arc length of 95.33 feet to a point of reverse curvature, said arc being subtended by a chord bearing and distance of North $81^{\circ}01'22''$ West, 94.93 feet; Course 4, thence Westerly along the arc of a curve concave Southerly having a radius of 300.00 feet, through a central angle of $18^{\circ}12'49''$, an arc length of 95.37 feet to a point lying on the Northerly line of said Section 34, said arc being subtended by a chord bearing and distance of North $81^{\circ}01'34''$ West, 94.97 feet; thence North $89^{\circ}52'36''$ East, departing said Northerly right of way line, along said Northerly line and along a non-tangent line, 820.66 feet to a point lying on the Westerly line of Isabella at Tamaya Phase 2, as recorded in Plat Book 76, pages 147 through 157, of said current Public Records; thence South $00^{\circ}45'10''$ East, departing said Northerly line and along said Westerly line, 14.86 feet to the Southwesterly corner thereof; thence North $89^{\circ}52'01''$ East, along the Southerly line of last said lands, 525.19 feet to the Point of Beginning.

Containing 2.86 acres, more or less.

SKETCH TO ACCOMPANY DESCRIPTION OF

A PORTION OF SECTION 34, TOWNSHIP 2 SOUTH, RANGE 28 EAST, DUVAL COUNTY, FLORIDA, BEING A PORTION OF PARCEL A, AS DESCRIBED AND RECORDED IN OFFICIAL RECORDS BOOK 16339, PAGE 1146, OF THE CURRENT PUBLIC RECORDS OF SAID COUNTY, BEING MORE PARTICULARLY DESCRIBED IN SEPARATE ATTACHMENT.

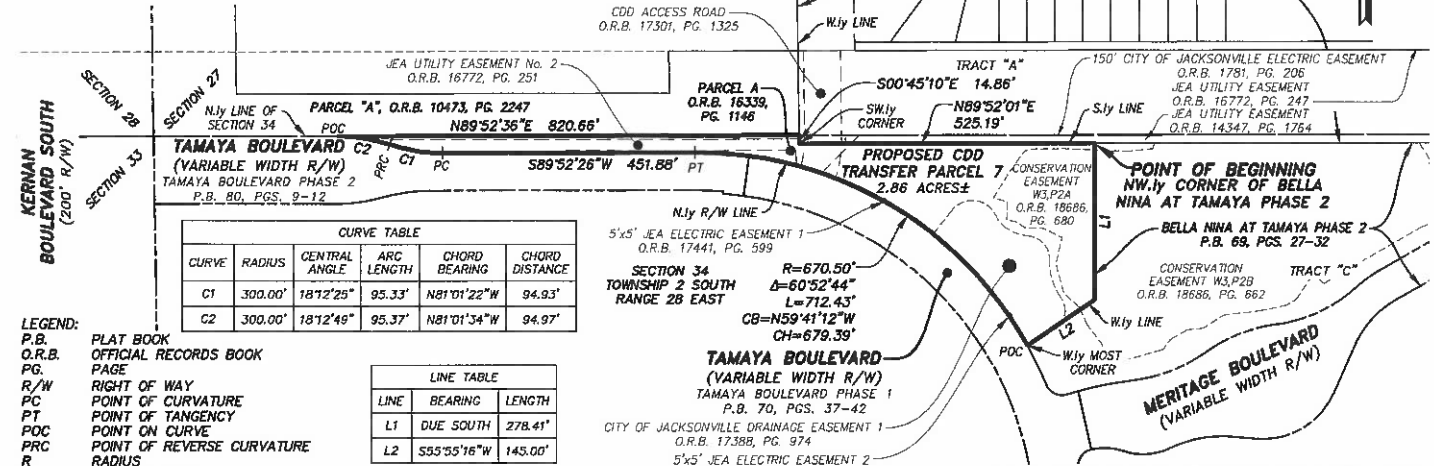

CURVE	RADIUS	CENTRAL ANGLE	ARC LENGTH	CHORD BEARING	CHORD DISTANCE
C1	300.00'	18°12'25"	95.33'	N81°01'22"W	94.93'
C2	300.00'	18°12'49"	95.37'	N81°01'34"W	94.97'

LINE	BEARING	LENGTH
L1	DUE SOUTH	278.41'
L2	S55°55'16"W	145.00'

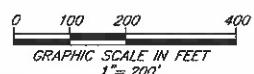

- LEGEND:**
- P.B. PLAT BOOK
 - O.R.B. OFFICIAL RECORDS BOOK
 - PG. PAGE
 - R/W RIGHT OF WAY
 - PC POINT OF CURVATURE
 - PT POINT OF TANGENCY
 - POC POINT ON CURVE
 - PRC POINT OF REVERSE CURVATURE
 - R RADIUS
 - Δ CENTRAL ANGLE
 - L ARC LENGTH
 - CB CHORD BEARING
 - CH CHORD DISTANCE
 - L1 TABULATED LINE DATA
 - C1 TABULATED CURVE DATA

REVISED PARCEL NUMBER; DECEMBER 8, 2023

GENERAL NOTES:

- 1) THIS IS NOT A SURVEY.
- 2) BEARINGS BASED ON THE NORTHERLY LINE OF SECTION 34 AS BEING NORTH 89°52'36" EAST.

ETM
 Surveying & Mapping, Inc.
 VISION • EXPERIENCE • RESULTS

14775 Old St. Augustine Road, Jacksonville, FL 32258
 Tel: (904) 642-8550 Fax: (904) 642-4165
 Certificate of Authorization No.: LB 3624

THIS ITEM HAS BEEN ELECTRONICALLY SIGNED AND SEALED USING A DIGITAL SIGNATURE. PRINTED COPIES OF THIS DOCUMENT ARE NOT CONSIDERED SIGNED AND SEALED AND THE SIGNATURE MUST BE VERIFIED ON ANY ELECTRONIC COPIES.



Digital Signature
 by: Bob L. Pittman, P.S.M.

SCALE: 1"=200'
 DATE: OCTOBER 10, 2023
BOB L. PITTMAN
 PROFESSIONAL SURVEYOR AND MAPPER
 STATE OF FLORIDA PSM No. 4827

PROPERTIES
DUVAL MAPS

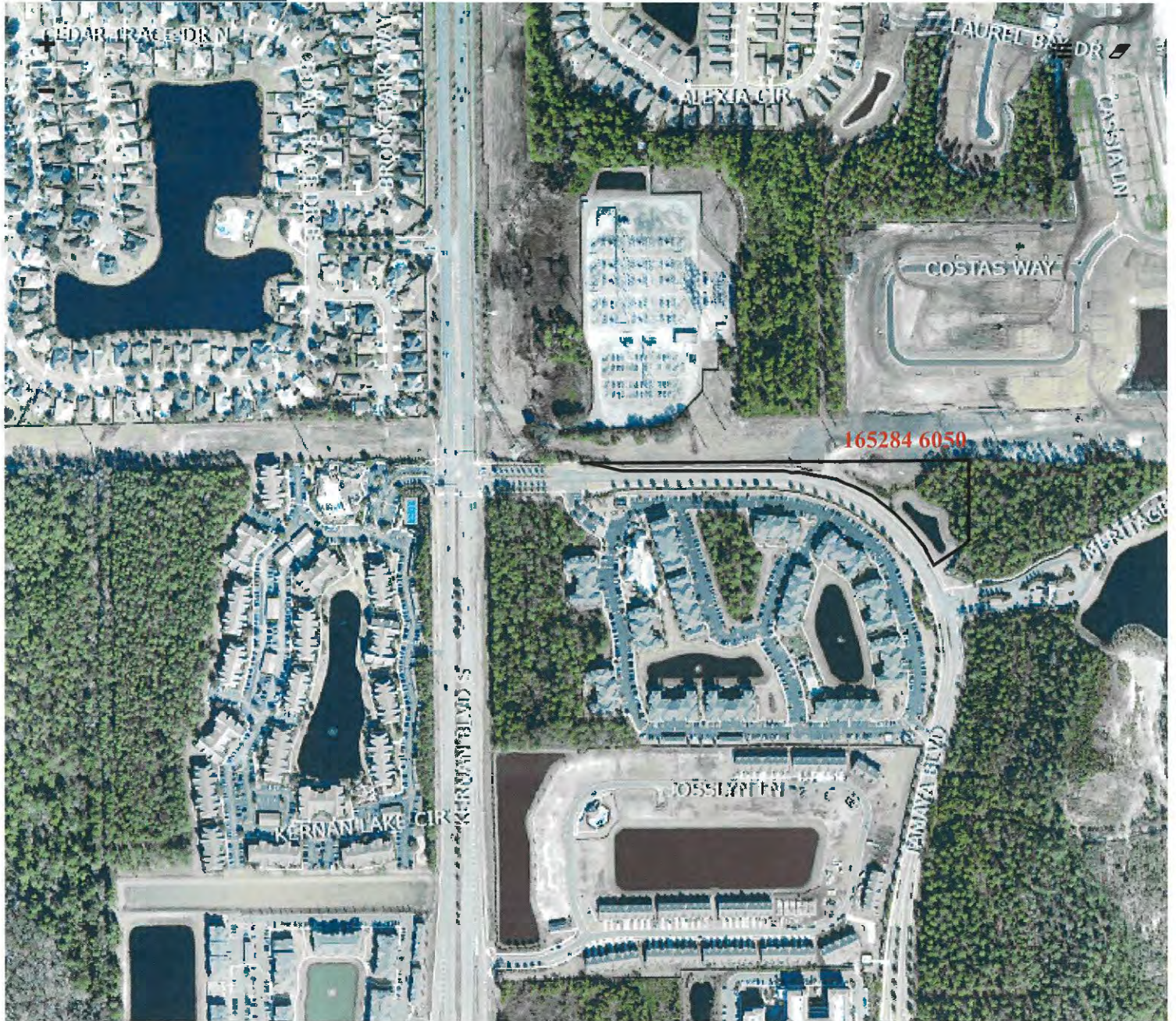

Mike Veazey

From: Mike Veazey
Sent: Thursday, December 7, 2023 4:39 PM
To: Mike Veazey
Subject: TAMAYA Blvd. Parcel





Sent from my iPhone

EXHIBIT 21



This agreement dated _____, is made between **Charles Aquatics, Inc.**, a Florida Corporation, and

Name Tamaya (Beach CDD) c/o David C. McInnes - Vesta District Services

Address 250 International Parkway, Suite 208

City Lake Mary State FL Zip 32746

Phone 321-263-0132 ext. 193 Fax _____

E-mail dmcinnes@vestapropertyservices.com

Hereinafter called "CLIENT".

1. **Charles Aquatics, Inc.**, agrees to provide fountain services in accordance with the terms and conditions of this Agreement at the following location(s): **Tamaya, Jacksonville, FL**
2. CLIENT agrees to pay **Charles Aquatics, Inc.**, the following sum(s) for the listed fountain services:

Fountain: Provide and install one Kasco 2hp 230v 1ph Fountain with Control Panel, 150ft of Power Cable and 6 standard nozzles (Linden, Balsam, Redwood, Spruce, and Birch). FOUNTAIN PACKAGE CARRIES A 3-YEAR MANUFACTURER WARRANTY

\$ 7,664.00

Optional Premium Nozzles: Mighty Oak, Madrone, Magnolia, Mahogany and Palm.

\$ 269.00

Lighting Options: LED LIGHTS CARRIES A 2- YEAR MANUFACTURER WARRANTY

LED3C11 3 LIGHT SET w/ 150' cable & colored lenses (fixed color)

\$ 1,163.00

RGB3C5 COLOR CHANGING w/ 150' cable

\$ 1,853.00

Fountain Selection – 2hp Kasco 208-240v 1ph – 150ft cable \$ 7,664.00

Optional Premium Nozzle Selection - \$

Light Set Selection – \$

TOTAL -

3. Client agrees to pay 25% deposit and then the balance in full within 10 days of installation. Client agrees to pay 1.5% of unpaid sum(s) after 30 days from installation. This quote is valid for 60 days.

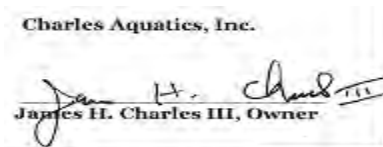

Representative of Charles Aquatics, Inc. 10-24-23
Date

Customer Signature Date

J SERIES PREMIUM NOZZLES

NEW FOR 3/4 & 1HP UNITS!

Premium Nozzles are now available for all J Series units and provide crisp and dramatic patterns. These Nozzles are purchased separately and have easy twist-and-lock installation.

PATTERN	3/4HP - NEW!	1HP - NEW!	2HP	3HP	5HP	7-1/2HP
Mighty Oak	10 x 24	13 x 34	14.5 x 40	19.5 x 51	24.5 x 58	27 x 60
Magnolia	9 x 29	11.5 x 37	13.5 x 44	18 x 60	23.5 x 75	26 x 80
Mahogany	11.5 x 28	14 x 34	16 x 40	21 x 58	28 x 64	29 x 72
Madrone	11.5 x 28	14 x 35	15 x 43	20 x 59	24 x 70	26 x 75
Palm	-	-	12 x 26	16 x 36	20.5 x 40	22 x 42

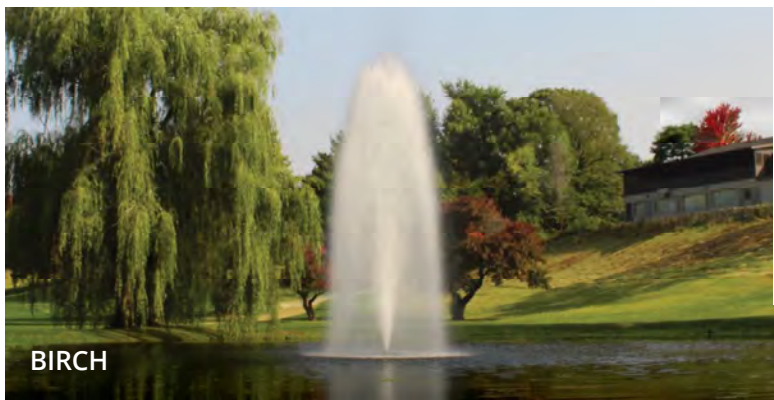
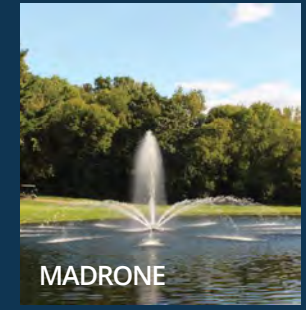

Kasco® FOUNTAINS

*New 2HP J Series Fountain with
New Mahogany Premium Nozzle*

NEW

REDESIGNED J SERIES FOR IMPROVED
PERFORMANCE & PATTERN DEFINITION

1-PIECE TAPERED FLOATS FOR
EASIER ASSEMBLY & IMPROVED LOOK

WHERE BEAUTY MEETS PERFORMANCE

Enhance the aesthetics and improve the health of your body of water with Kasco Fountains. All fountains deliver reliable and efficient performance, and feature marine-grade stainless steel components for protection in harsh environments such as salt water. Explore the multiple pattern options in our J Series line and aerating power of the VFX fountain.

kascomarine.com // 715-262-4488 // sales@kascomarine.com

NEW

Redesigned 2, 3, 5 and 7-1/2HP J Series Fountains

- Better performance and flow without increased amp draw
- Increased flow for dramatically cleaner and defined patterns
- New Balsam 3-Tier pattern
- New Mighty Oak premium pattern
- 1-piece tapered float for easier assembly and improved look at the surface
- Twist and lock nozzles for easy pattern changes
- Snap-on light clips for easy light fixture installations (purchased separately)

J SERIES FOUNTAINS

Kasco J Series Fountains offer dramatic, aesthetically pleasing displays at the best value on the market. Designed with both beauty and function in mind, each package includes 5 twist-and-lock nozzles - **at no extra charge** - allowing you to choose from attention demanding geysers to elegant 3-tier displays.

- Available as 3/4, 1, 2, 3, 5 and 7-1/2HP units, 120V and 208-240V, and single and three phase options
- Package includes unit, float, mooring ropes, power cord, nozzles and control panel with human-rated GFCI protection
- Complete packages are ETL approved to UL and CSA standards
- Operates in as little as 15-30 in. of water, depending on HP
- 2 year warranty on 3/4HP and 1HP units
- 3 year warranty on 2HP units (optional 5 year extended warranty available)
- 5 year warranty on 3, 5 and 7-1/2HP units

New 1-Piece Float on 3HP J Series



MODEL DETAILS	UNIT SIZE (HP)											
	3/4HP		1HP		2HP		3HP		5HP		7-1/2HP	
Model	3400JF	3400HJF	4400JF	4400HJF	8400JF	2.3JF	3.1JF	3.3JF	5.1JF	5.3JF	7.3JF	
Voltage	120	208-240	120	208-240	208-240		208-240		208-240		208-240	
Phase	1	1	1	1	1	3	1	3	1	3	3	
Amperage	6.7	3.3	10.7	5.3	10	7.5	13.4	10.3	20	16	20	
PATTERNS	DISPLAY DIMENSIONS (FT.)											
	H	W	H	W	H	W	H	W	H	W	H	W
Willow	6.5	21	9	31	-	-	-	-	-	-	-	-
Sequoia	13	8	18	11	-	-	-	-	-	-	-	-
Cypress	7	17	9	28	-	-	-	-	-	-	-	-
Linden	9	29	12	31	15.5	38	20.5	38	24.5	46	26	46
Birch	7	5	11	8	11	10	16	12	24	14	26	16
NEW: BALSAM	-	-	-	-	14	32	19	34	18	34	21	36
Spruce	-	-	-	-	21	10	26	12	31	12	34	12
Redwood	-	-	-	-	22	6	27	6	32	6	36	8

Product Notes:

1. Cords are in 50 ft. increments up to 200 ft. on both 120V and 208-240V.
2. 208-240V units also offer 250 ft., 300 ft., 400 ft., and 500 ft. options.
3. 50 ft. power cord not available for 5 and 7-1/2HP units



NEW**BALSAM - 3HP****NEW****REDWOOD - 3HP****NEW****LINDEN - 3HP****NEW****SPRUCE - 5HP****WILLOW - 1HP****CYPRESS - 3/4HP****SEQUOIA - 1HP****BIRCH - 2HP****NEW****Redesigned Nozzles & New Mighty Oak Pattern**

J SERIES PREMIUM NOZZLES

Further define your J Series experience with a Premium Nozzle for the 2, 3, 5, and 7-1/2HP units. Redesigned to allow more flow, Kasco's premium patterns provide crisp and distinct streams of water, for a more attractive display. New to the collection is the Mighty Oak pattern featuring 3 tiers with 8 streams in each, creating a beautifully arched cascade. Premium nozzles easily twist and lock into place and are purchased separately.

NEW**MIGHTY OAK****NEW****MAGNOLIA****NEW****MAHOGANY****NEW****PALM**

PATTERNS	DISPLAY DIMENSIONS (FT.)							
	2 HP		3HP		5HP		7-1/2HP	
	H (ft.)	W (ft.)	H (ft.)	W (ft.)	H (ft.)	W (ft.)	H (ft.)	W (ft.)
NEW: MIGHTY OAK	14.5	40	19.5	51	24.5	58	27	60
Magnolia	13.5	44	18	60	23.5	72	26	80
Mahogany	16	40	21	58	28	64	29	72
Palm	12	26	16	36	20.5	40	22	42

NEW

1-Piece tapered float for 2 & 5HP units provides easier installation & improved look.



New 1-Piece Tapered Float on 5HP VFX



VFX SERIES FOUNTAINS

Kasco VFX Series is the choice for those wanting an elegant display but also require superior aeration benefits. These units are efficient and easy to install and operate.

- Available in 1/2, 3/4, 1, 2 and 5HP options, 120V and 208-240V, and single and three phase options
- Includes unit, float, bottom screen, mooring ropes, power cord, and control panel with GFCI protection
- Snap-on light clips for easy light fixture installations (purchased separately)
- Operates in as little as 15 in. of water
- ETL approved to UL and CSA standards
- 2 year warranty on 1/2, 3/4 and 1HP units
- 3 year warranty on 2 and 5HP units (optional 5 year extended warranty available)

HP	PART NUMBER	DISPLAY		VOLT	PHASE	AMPS
		H (FT.)	W (FT.)			
1/2	2400VFX	5	15	120	1	5.6
3/4	3400VFX	5.5	21	120	1	7.3
	208-240			3.7		
1	4400VFX	8	26	120	1	11.3
	4400HVFX			208-240		5.7
2	8400VFX	8	32	208-240	1	11
	2.3VFX				3	7.5
5	5.1VFX	9	34	208-240	1	20
	5.3VFX				3	16

Product Notes:

1. 2 and 5HP available in three phase 460-480V in approved locations. Contact Kasco for details.
2. Cords are in 50 ft. increments up to 200 ft. on both 120V and 208-240V units
3. 208-240V units also offer 250 ft., 300 ft., 400 ft., and 500 ft. options.
4. 50 ft. power cord not available for 5HP units.

FOUNTAIN LIGHTING

Kasco WaterGlow lighting will dramatically illuminate your fountain or aerator throughout the nighttime hours. Available in composite or stainless steel housings and in several color options, these versatile LED lights are a perfect addition to your display. **NEW** Snap-on light clips are now included with 3 and 6 fixture RGB LED and Composite LED kits, making installation even easier. Compatible with all J Series and VFX fountains.



3/4HP J Series Linden Nozzle, RGB LED Lights

RGB LED

Choose between 9 colors, 3 rhythmic sequences and the addition of music to hand pick the perfect display.

- Colors include: white, cool white, red, green, blue, orange, yellow, cyan and magenta
- 3 fixture kit works best for 1/2 - 1HP units, 6 fixture kits work best for 2 - 3HP units
- 1-piece composite housing features ultra sonic weld around the lens ensuring water-tight operation



2HP J Series Mahogany Premium Nozzle, Composite LED Lights

Composite LED

These lighting systems feature durable composite housings to shine brilliantly into the evening hours.

- Displays classic white and includes red, green, blue and amber lenses and lens caps
- 3 fixture kits works best for 1/2 - 1HP units, 6 fixture kits work best or 2 - 5HP
- 1-piece composite housing features ultra sonic weld around the lens ensuring water-tight operation



3HP J Series Redwood Nozzle, Stainless Steel LED Lights

Stainless Steel LED

Featuring a durable, stainless steel enclosure, these lights will ensure an elegant and classic display.

- Displays classic white and includes red, green, blue and amber lenses and lens caps
- 3 fixture kit works best for 1 - 3HP units, 6 fixture kits work best for 3 - 7-1/2HP units
- UL / CSA Listed

EXHIBIT 22



The Lake Doctors, Inc.
Aquatic Management Services

Corporate Offices
3543 State Road 419
Winter Springs, FL 32708
1-800-666-5253
lakes@lakedoctors.com
www.lakedoctors.com

Sales Agreement
AIRMAX POND SERIES

MAS720157

This Agreement, made this _____ day of _____, 20____ is between The Lake Doctors, Inc., a Florida Corporation, hereinafter called "THE LAKE DOCTORS" and

PROPERTY NAME (Community/Business/Individual) _____

MANAGEMENT COMPANY _____

INVOICING ADDRESS _____

CITY _____ STATE _____ ZIP _____ PHONE () _____

EMAIL ADDRESS _____ EMAIL INVOICE: YES OR NO

THIRD PARTY COMPLIANCE/REGISTRATION: YES OR NO THIRD PARTY INVOICING PORTAL: YES OR NO

***If a Third Party Compliance/Registration or an Invoice Portal is required; it is the customer's responsibility to provide the information.*

Hereinafter called "CUSTOMER" PURCHASE ORDER #: _____

The parties hereto agree to follows:

A. THE LAKE DOCTORS agrees to install or supply the following equipment in accordance with the terms and conditions of this Agreement in the following locations(s):

One (1) Airmax PondSeries Fountain for Tamaya – Beach CDD, Jacksonville Florida.

Includes 2hp, 240V, single phase, floating fountain with 3 Display Nozzles and low profile float assembly. Stainless steel, fully sealed, uL approved, stainless-steel motor, pump system and stainless intake. NEMA 3R powder coated control panel with digital timers. Optional: RGBW Color-changing, Energy efficient high output completely sealed lighting with RF Remote. Deposit must be received prior to installation. Note: All fountains require a properly equipped, dedicated electrical circuit to avoid potential hazards and nuisance tripping
***Excludes on shore electrical repair, if needed. 208V or less voltage to motor will affect fountains performance and reliability.**

B. CUSTOMER agrees to pay THE LAKE DOCTORS, its agents or assigns, the following sum for specified equipment:

1.	2hp 240Volt PondSeries Fountain with 150' cable	\$	<u>6,558.00</u>
2.	4 X RGBW Color-changing Light Set with remote & 150' cable	\$	<u>1,820.00</u>
3.	Control Panel, NEMA 3R, powder coated with GFCI Protection and digital timers	\$	<u>INCLUDED</u>
4.	Three (3) year manufacturer warranty on Fountain and LED lighting	\$	<u>INCLUDED</u>
5.	Free Shipping Discount	\$	<u>INCLUDED</u>
6.	Assembly, Delivery & Anchoring fountain*	\$	<u>500.00</u>
7.	7.5% Sales Tax	\$	<u>Exempt</u>
	Total of Services Accepted	\$	<u>8,878.00</u>

\$4,439.00 deposit shall be payable upon execution of this Agreement, the balance shall be payable upon installation plus any taxes, including sales use taxes, fees or charges that are imposed by any governmental body relating to the service provided under this Agreement. **THE LAKE DOCTORS** considers this sale as made in Florida and is not responsible for the payment of any out-of-state (non-Florida) taxes except as required by law.

- C. THE LAKE DOCTORS agrees to sell only products with a demonstrated reliability and quality.
- D. THE LAKE DOCTORS agrees to supply equipment within **thirty (30) business days**, subject to availability, with receipt of this executed Agreement and required advance deposit.
- E. The offer contained herein is withdrawn and this Agreement shall have no further force and effect unless executed and returned by CUSTOMER to THE LAKE DOCTORS on or before **October 20, 2023**.
- F. The terms and conditions form an integral part of this Agreement, and CUSTOMER hereby acknowledges that he has read and is familiar with the contents thereof. Agreement must be returned in its entirety to be considered valid.

THE LAKE DOCTORS, INC.

CUSTOMER

Signed _____ Dated _____

Mark A. Seymour, Sales Manager

Name _____

TERMS AND CONDITIONS

1. Equipment sold by THE LAKE DOCTORS is warranted to be free from defects in materials and workmanship per warranty of the respective equipment manufacturers. For details, see MANUFACTURER'S warranty.

Eco Series

- ½ HP- 3 Years Warranty on Fountain and Control Panel on Manufacturer Materials and Workmanship
- LED and RGBW Light Set- 3 Years Warranty Parts

Pond Series

- 1 HP & 2HP – 3 Years Warranty on Fountain and Control Panel on Manufacturer Material and Workmanship
- LED and RGBW Light Set- 3 Years Warranty Parts

The liability is limited to the repair or replacement of such items deemed by MANUFACTURER to be defective and will not include items damaged by misuse, vandalism, theft, acts of God or other causes. CUSTOMER shall bear the cost of delivering such defective items to THE LAKE DOCTORS or MANUFACTURER for repair. Any repairs, alteration or modifications made by anyone other than an authorized representative of THE LAKE DOCTORS or MANUFACTURER will void the warranty. Warranty work will not be performed or paid for by THE LAKE DOCTORS or MANUFACTURER unless all past due balances are paid in full. No warranty is made or implied regarding the ability of the equipment to control algae, prevent fish kills, control odors or other performance criteria not directly related to proper mechanical function of the equipment.

2. Failure to follow the MANUFACTURER'S required maintenance may void warranty.
3. Items not covered under our warranty will be treated and billed as regular service calls. Examples of non-warranty work include cleaning of light lenses, unclogging of nozzles and filters, valve adjustments, resetting tripped breakers.
4. CUSTOMER shall be responsible for providing proper electrical power and performing electrical hookups. All electrical work shall meet all applicable governmental requirements. Said power shall be supplied to a designated site agreed upon by THE LAKE DOCTORS and CUSTOMER and generally within 30' or less of lake or ponds edge. In all cases, power supplied should be in accordance with Article 680 and other appropriate provisions of the National Electrical Code including the use of ground fault circuit interrupter-type breakers on each submersible equipment circuit above 15 volts between conductors. It shall be CUSTOMER'S responsibility to ensure that proposed equipment to be supplied by THE LAKE DOCTORS meets all other governmental standards, including but not limited to, local electrical codes, building codes, etc. Additionally, CUSTOMER shall be responsible for obtaining any necessary permits.
5. Due to possible electrical shock hazards resulting from improper functioning of defective equipment, THE LAKE DOCTORS strongly advises CUSTOMER and other responsible parties to prohibit swimming and wading in ponds or bodies of water in which electrical equipment has been installed. Posted notice is advised.
6. THE LAKE DOCTORS does not assume any liability whatsoever for damages, losses or conditions arising from improper use or maintenance of equipment installed by THE LAKE DOCTORS or MANUFACTURER. Furthermore, THE LAKE DOCTORS and MANUFACTURER assumes no liability whatsoever for damages, losses or conditions arising from equipment purchased from THE LAKE DOCTORS and improperly installed, used or maintained by CUSTOMER or others.
7. THE LAKE DOCTORS agrees to hold CUSTOMER harmless from any loss, damage or claims arising out of the sole negligence of THE LAKE DOCTORS. However, THE LAKE DOCTORS shall in no event be liable to CUSTOMER, or others, for indirect, special or consequential damages.
8. Neither party shall be responsible in damages, penalties or otherwise for any failure or delay in the performance of any of its obligations hereunder caused by strikes, riots, war, acts of God, accidents, governmental orders and regulations, curtailment or failure to obtain sufficient material, or other force majeure condition (whether or not of the same class or kind as those set forth above) beyond its reasonable control and which, by the exercise of due diligence, it is unable to overcome.
9. THE LAKE DOCTORS shall maintain the following insurance coverage and limits: (a) Workman's Compensation with statutory limits; (b) Automobile Liability; (c) Comprehensive General Liability, including Pollution Liability, Property Damage, Completed Operations and Product Liability. A Certificate of Insurance will be provided upon request. A Certificate of Insurance naming CUSTOMER as "Additional Insured" may be provided at CUSTOMER'S request. CUSTOMER agrees to pay for any additional costs of insurance requirements over and above that provided by THE LAKE DOCTORS.
10. This Agreement is not assignable by CUSTOMER except upon prior written consent by THE LAKE DOCTORS.
11. Termination of Agreement in writing by CUSTOMER after initiation of Agreement will be subject to a 20% restocking fee plus all shipping costs and subject to a charge equal to time and materials expended upon time of cancellation.
12. Quotations are made and orders accepted on a firm price basis provided customer authorizes shipment and delivery within a period of forty-five (45) days after execution of Sales Agreement. Orders shipped after ninety (90) days are subject to prices in effect on date of shipment. All shipments F.O.B. shipping point.
13. Special or custom orders are not returnable for credit. A special or custom order is defined by THE LAKE DOCTORS as any order deviating from, or modified from, standard items, kits or systems. This shall include any component or system custom built to buyer's specifications.
14. This Agreement constitutes the entire agreement of the parties hereto and shall be valid upon acceptance by THE LAKE DOCTORS Corporate Office. No oral or written alterations or modifications of the terms contained herein shall be valid unless made in writing and accepted by an authorized representative of both THE LAKE DOCTORS and CUSTOMER.
15. THE LAKE DOCTORS reserves the right to impose a monthly service charge on past due balances. CUSTOMER agrees to reimburse THE LAKE DOCTORS for all processing fees for registering with third party companies for compliance monitoring services.
16. Should it become necessary for THE LAKE DOCTORS to bring action for collection of monies due and owing under this Agreement, CUSTOMER agrees to pay collection costs, including, but not limited to, reasonable attorneys' fees (including those on appeal) and court costs, and all other expenses incurred by THE LAKE DOCTORS resulting from such collection action.
17. If the scope of work changes after the execution of the Agreement, the Agreement can be cancelled or the customer will assume any additional cost to complete the modified agreement.

AIRMAX POND SERIES 2HP FOUNTAIN WITH CROWN & TRUMPET PATTERN 13'H X 38'W



AIRMAX[®]



FOUNTAIN AERATION

Make Your Pond the Destination



Why Airmax Fountains?

- Largest Most Defined Spray Patterns
- Innovative Low Maintenance Design
- Best In Class Energy Efficiency
- Made in the USA



Tranquility Starts With Airmax

Airmax Fountains Can Ensure Health AND Beauty for Your Pond

Fountain Comparison Chart	EcoSeries	PondSeries	LakeSeries
Horsepower Options			
Minimum Operating Depth	1/2 HP	1/2 HP, 1 HP & 2 HP	2 HP, 3 HP & 5 HP
Float Type	24"	36"	36", 48" & 60"
Light Set Options	Drop In	Drop In	ISP Float System
Warranty	2, 4 & 8 Lights	2, 4 & 8 Lights	9 & 12 Lights
	3 Years	3 Years	5 Years



EcoSeries™ Fountain

Bold, Beautiful Patterns & Energy Efficient



PREMIUM DISPLAYS

- Well defined, industry leading spray patterns for strong, stunning displays
- Airmax exclusive quick-change nozzles can be switched out in seconds
- Low-profile, drop-in style, float design keeps the fountain steady and balanced in the water
- Includes 3 spray patterns. Additional premium nozzles available

ENGINEERED TO LAST

- Asynchronous energy efficient motor is water cooled, powerful and built to last
- Low maintenance: No oil, seals or bearings to change
- Stainless-steel wrapped motor lead protects against animal chewing
- Power cord strain relief keeps connections secure
- Ground-fault circuit interrupter (GFCI) protection

EFFICIENT DESIGN

- Bottom-draw design pulls water from deeper in the pond for better aeration
- More performance with lower operating cost than comparable fountains
- High-quality control panels, with standard dual digital timers to accommodate fountain and lights
- Under water quick disconnect, standard with all cords
- 3-year warranty on motor and components

ADDITIONAL OPTIONS

- Optional RGBW light sets bring your fountain to life at night
- Stainless-steel or Polyflex power cord protection



Top Down View of Float and Quick-Change Nozzle



Bottom-Draw Pulls Water From Deeper in the Pond

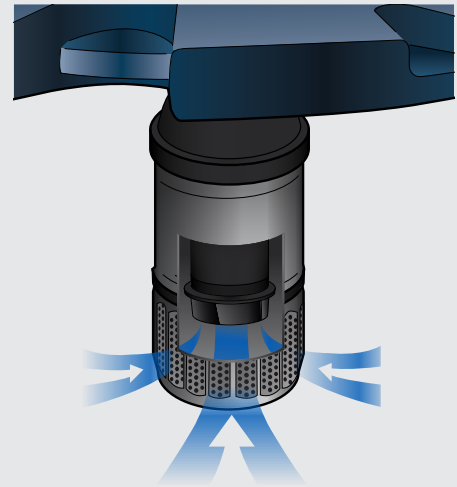

Airmax Control Panel Comes Standard with Dual Digital Timers for Both Fountain & Lights





**Crown & Trumpet
INCLUDED SPRAY PATTERN**

EcoSeries Pattern Dimensions		
HP	Trumpet	Crown
1/2 HP	8' H x 4' W	4' H x 32' W

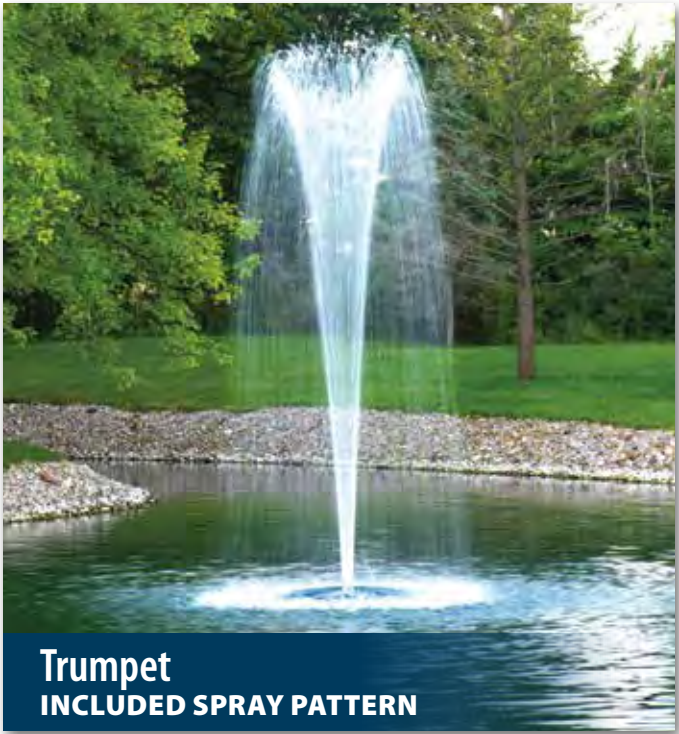

**Trumpet
INCLUDED SPRAY PATTERN**

EcoSeries Pattern Dimensions	
HP	H x W
1/2 HP	14' H x 7' W



**Classic
INCLUDED SPRAY PATTERN**

EcoSeries Pattern Dimensions	
HP	H x W
1/2 HP	6' H x 16' W





Double Arch & Geyser
OPTIONAL SPRAY PATTERN

EcoSeries Pattern Dimensions			
HP	Geyser	1st Tier	2nd Tier
1/2 HP	9' H	7' H x 12' W	5' H x 34' W



Single Arch
OPTIONAL SPRAY PATTERN

EcoSeries Pattern Dimensions	
HP	H x W
1/2 HP	8' H x 16' W





Double Arch OPTIONAL SPRAY PATTERN

EcoSeries Pattern Dimensions

HP	1st Tier	2nd Tier
1/2 HP	10' H x 16' W	5' H x 38' W



Blossom (Crown & Arch) OPTIONAL SPRAY PATTERN

EcoSeries Pattern Dimensions

HP	1st Tier	2nd Tier
1/2 HP	4' H x 6.5' W	1.5' H x 11' W





PondSeries® Fountain

Superior Performance, Stunning Displays

PREMIUM DISPLAYS

- Crisp spray patterns provide a beautiful aerating display
- Airmax exclusive quick-change nozzles can be switched out in seconds
- Low-profile, drop-in style, float design keeps the fountain steady and balanced in water
- Includes 3 spray patterns. Additional premium nozzles available

LONG-LASTING DURABILITY

- Stainless-steel Continuous Duty Water Cooled Motor is maintenance-free, providing long-lasting performance without annual maintenance costs
- Independent Pump System for longevity and protection against wear to motor, shaft and seals
- Integrated Cooling Shroud for maximum motor life and efficiency
- Stainless-steel motor lead protects against damage from debris or animal chewing
- Power cord strain relief keeps connections secure
- Oversized modular intake screen prevents clogging

SUPERIOR PERFORMANCE

- Bottom-draw design pulls water from deeper in the pond for better aeration
- More performance with lower operating cost than comparable fountains
- High-quality control panels, with standard dual digital timers to accommodate fountain and lights
- 3-year warranty on unit and control panel

ADDITIONAL OPTIONS

- Optional RGBW light sets bring your fountain to life at night
- Stainless-steel or Polyflex power cord protection



Top Down View of Float and Quick-Change Nozzle



Bottom-Draw Design Pulls Water From Deeper in the Pond and Through the Integrated Cooling Shroud

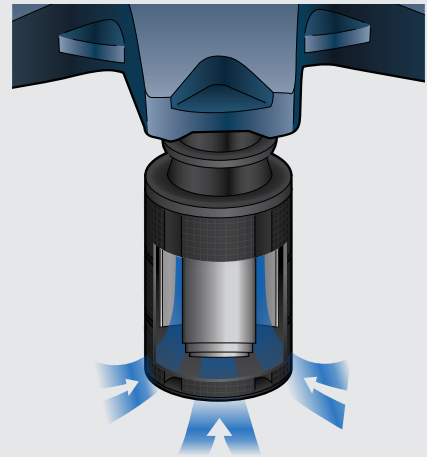

Airmax Control Panel Comes Standard with Dual Digital Timers for Both Fountain & Lights





**Crown & Trumpet
INCLUDED SPRAY PATTERN**

PondSeries Pattern Dimensions		
HP	Trumpet	Crown
1/2 HP	8' H x 6' W	4.5' H x 32' W
1 HP	11' H x 6' W	4.5' H x 32' W
2 HP	13' H x 8' W	6.5' H x 38' W

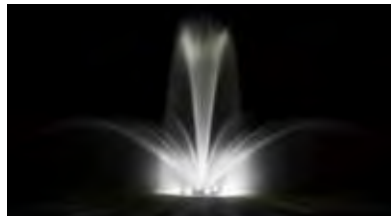

**Trumpet
INCLUDED SPRAY PATTERN**



**Classic
INCLUDED SPRAY PATTERN**

PondSeries Pattern Dimensions	
HP	H x W
1/2 HP	12.5' H x 5' W
1 HP	16' H x 6' W
2 HP	17' H x 7' W



PondSeries Pattern Dimensions	
HP	H x W
1/2 HP	5.5' H x 13' W
1 HP	9.5' H x 23' W
2 HP	14' H x 28' W





Double Arch & Geyser
OPTIONAL SPRAY PATTERN

PondSeries Pattern Dimensions			
HP	Geyser	1st Tier	2nd Tier
1/2 HP	9' H	6' H x 7' W	4' H x 28' W
1 HP	8.5' H	5.5' H x 13' W	4' H x 30' W
2 HP	9.5' H	6' H x 15' W	4' H x 32' W



Single Arch
OPTIONAL SPRAY PATTERN

PondSeries Pattern Dimensions	
HP	H x W
1/2 HP	9' H x 14' W
1 HP	8' H x 22' W
2 HP	9' H x 24' W





Double Arch OPTIONAL SPRAY PATTERN

PondSeries Pattern Dimensions

HP	1st Tier	2nd Tier
1/2 HP	8' H x 8' W	4.5' H x 28' W
1 HP	9' H x 10' W	5' H x 34' W
2 HP	10' H x 10' W	5.5' H x 36' W



Blossom (Crown & Arch) OPTIONAL SPRAY PATTERN

PondSeries Pattern Dimensions

HP	1st Tier	2nd Tier
1/2 HP	5' H x 7' W	2' H x 13' W
1 HP	6.5' H x 10' W	2' H x 19' W
2 HP	8.5' H x 10' W	2.5' H x 22' W



LakeSeries® Fountain

Unrivalled Performance, Striking Displays



PREMIUM DISPLAYS

- Large high-volume laminar spray patterns
- Airmax exclusive quick-change nozzles can be switched out in seconds
- Industry Exclusive ISP Float System provides maximum stability allowing for larger, higher volume patterns while eliminating all float noise associated with falling water
- Multiple spray pattern nozzles available

INNOVATIVE DESIGN

- Stainless-steel Continuous Duty Water Cooled Motor is maintenance-free, providing long-lasting performance without annual maintenance costs
- Independent Pump System for longevity and protection against wear to motor, shaft and seals
- Integrated Cooling Shroud for maximum motor life and cooling
- Stainless-steel motor lead protects against damage from debris or animal chewing
- Power cord strain relief keeps connections secure
- Oversized modular intake screen prevents clogging

ENGINEERED EXCELLENCE

- Bottom-draw design pulls water from deeper in the pond for better aeration
- Greater performance with lower operating cost than comparable fountains
- High-quality control panels, with standard dual digital timers to accommodate fountain and lights
- 5-year warranty on unit and control panel

ADDITIONAL OPTIONS

- Optional RGBW light sets bring your fountain to life at night
- Stainless-steel or Polyflex power cord protection



Industry Exclusive ISP Float System



Bottom-Draw Design Pulls Water From Deeper in the Pond and Through the Integrated Cooling Shroud

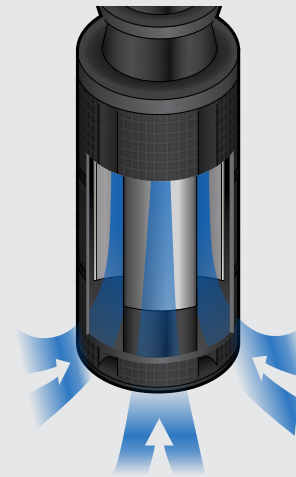

Airmax 230v Control Panel Comes Standard with Dual Digital Timers for Both Fountain & Lights





Crown & Trumpet
OPTIONAL SPRAY PATTERN

LakeSeries Pattern Dimensions		
HP	Trumpet	Crown
2 HP	14' H x 10' W	6' H x 46' W
3 HP	15' H x 10' W	8' H x 50' W
5 HP	24' H x 8' W	12' H x 56' W

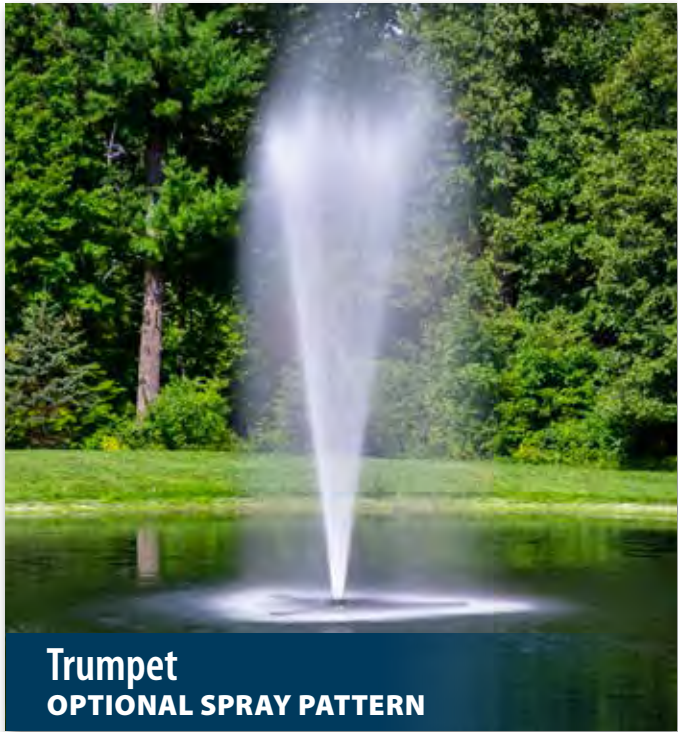

Trumpet
OPTIONAL SPRAY PATTERN

LakeSeries Pattern Dimensions	
HP	H x W
2 HP	20' H x 9' W
3 HP	23' H x 10' W
5 HP	30' H x 10' W

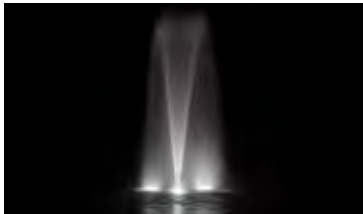

Classic
OPTIONAL SPRAY PATTERN

LakeSeries Pattern Dimensions	
HP	H x W
2 HP	11' H x 30' W
3 HP	13' H x 30' W
5 HP	16' H x 35' W

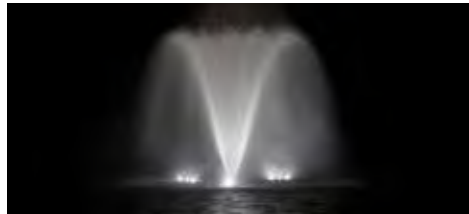



Single Arch
OPTIONAL SPRAY PATTERN

LakeSeries Pattern Dimensions	
HP	H x W
2 HP	13' H x 30' W
3 HP	15' H x 40' W
5 HP	20' H x 40' W

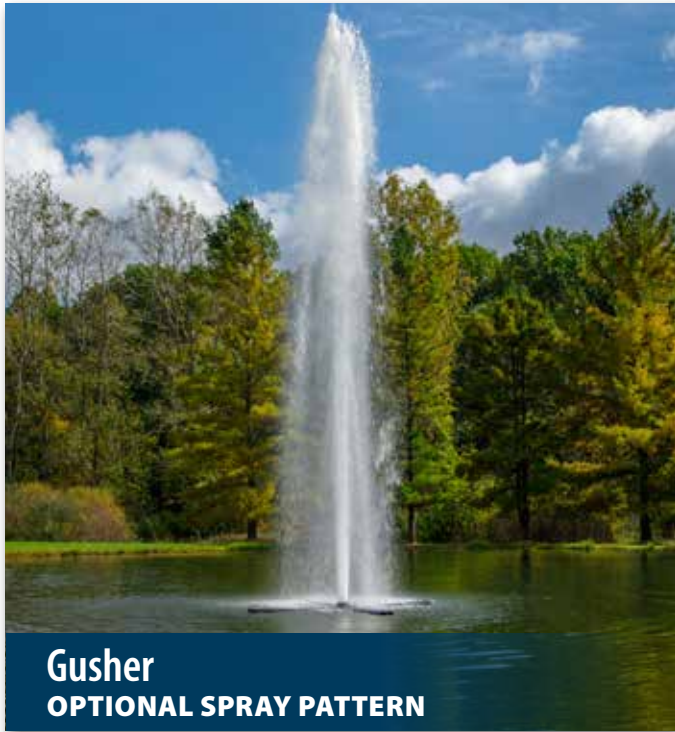

Gusher
OPTIONAL SPRAY PATTERN

LakeSeries Pattern Dimensions	
HP	Height
2 HP	21' H
3 HP	28' H
5 HP	35' H



Blossom (Crown & Arch)
OPTIONAL SPRAY PATTERN

LakeSeries Pattern Dimensions		
HP	1st Tier	2nd Tier
2 HP	14' H x 16' W	2.5'h x 20' W
3 HP	16' H x 11' W	3' H x 24' W
5 HP	17' H x 17' W	5' H x 30' W





Double Arch
OPTIONAL SPRAY PATTERN

LakeSeries Pattern Dimensions		
HP	1st Tier	2nd Tier
2 HP	13' H x 16' W	6' H x 46' W
3 HP	16' H x 12' W	8' H x 50' W
5 HP	20' H x 20' W	10' H x 60' W

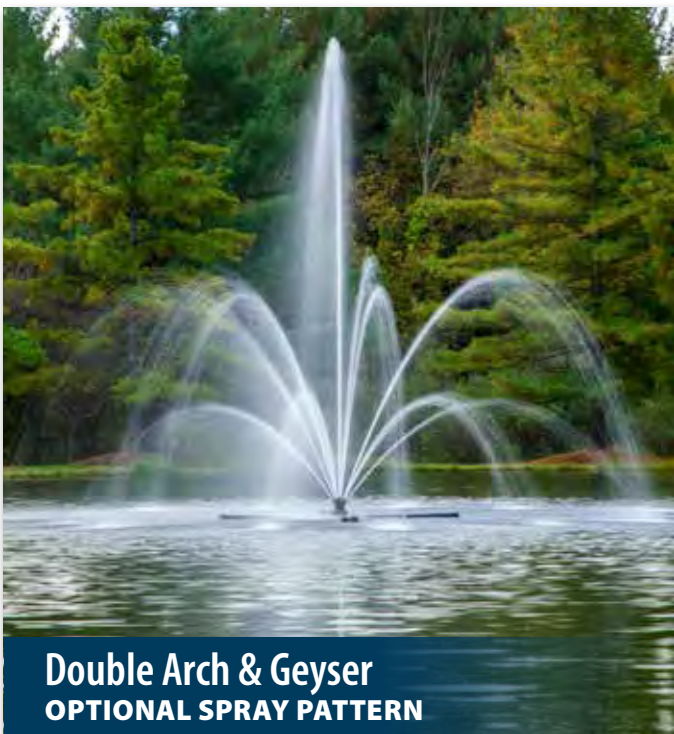

Double Arch & Geyser
OPTIONAL SPRAY PATTERN

LakeSeries Pattern Dimensions			
HP	Geyser	1st Tier	2nd Tier
2 HP	13' H	7' H x 20' W	4' H x 30' W
3 HP	15' H	9' H x 20' W	6' H x 40' W
5 HP	20' H	11' H x 22' W	7' H x 48' W



Crown & Gusher
OPTIONAL SPRAY PATTERN

LakeSeries Pattern Dimensions		
HP	Gusher	Crown
2 HP	15' H	8' H x 52' W
3 HP	16' H	11' H x 50' W
5 HP	22' H	13' H x 60' W



Airmax Warranty Information

- EcoSeries & PondSeries Fountain - 3 Years
- LakeSeries Fountain - 5 Years
- Airmax RGBW Light Sets - 3 Years



Spray Pattern Dimensions



	Crown & Trumpet		Trumpet	Classic	Gusher	Crown & Gusher	
EcoSeries	Trumpet	Crown	H x W	H x W	H x W	Gusher	Crown
1/2 HP	8' H x 4' W	4' H x 32' W	14' H x 7' W	6' H x 16' W	N/A	N/A	N/A
PondSeries	Trumpet	Crown	H x W	H x W	H x W	Gusher	Crown
1/2 HP	8' H x 6' W	4.5' H x 32' W	12.5' H x 5' W	5.5' H x 13' W	N/A	N/A	N/A
1 HP	11' H x 6' W	4.5' H x 32' W	16' H x 6' W	9.5' H x 23' W	N/A	N/A	N/A
2 HP	13' H x 8' W	6.5' H x 38' W	17' H x 7' W	14' H x 28' W	N/A	N/A	N/A
LakeSeries	Trumpet	Crown	H x W	H x W	H x W	Gusher	Crown
2 HP	14' H x 10' W	6' H x 46' W	20' H x 9' W	11' H x 30' W	21' H	15' H	8' H x 52' W
3 HP	15' H x 10' W	8' H x 50' W	23' H x 10' W	13' H x 30' W	28' H	16' H	11' H x 50' W
5 HP	24' H x 8' W	12' H x 56' W	30' H x 10' W	16' H x 35' W	35' H	22' H	13' H x 60' W

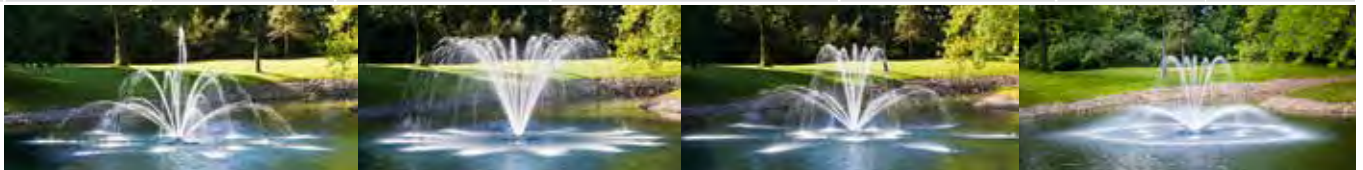

	Double Arch & Geyser			Single Arch	Double Arch		Blossom (Crown & Arch)	
EcoSeries	Geyser	1st Tier	2nd Tier	H x W	1st Tier	2nd Tier	1st Tier	2nd Tier
1/2 HP	9' H	7' H x 12' W	5' H x 34' W	8' H x 16' W	10' H x 16' W	5' H x 38' W	4' H x 6.5' W	1.5' H x 11' W
PondSeries	Geyser	1st Tier	2nd Tier	H x W	1st Tier	2nd Tier	1st Tier	2nd Tier
1/2 HP	9' H	6' H x 7' W	4' H x 28' W	9' H x 14' W	8' H x 8' W	4.5' H x 28' W	5' H x 7' W	2' H 13' W
1 HP	8.5' H	5.5' H x 13' W	4' H x 30' W	8' H x 22' W	9' H x 10' W	5' H x 34' W	6.5' H x 10' W	2' H x 19' W
2 HP	9.5' H	6' H x 15' W	4' H x 32' W	9' H x 24' W	10' H x 10' W	5.5' H x 36' W	8.5' H x 10' W	2.5' H x 22' W
LakeSeries	Geyser	1st Tier	2nd Tier	H x W	1st Tier	2nd Tier	1st Tier	2nd Tier
2 HP	13' H	7' H x 20' W	4' H x 30' W	13' H x 30' W	13' H x 16' W	6' H x 46' W	14' H x 16' W	2.5' H x 20' W
3 HP	15' H	9' H x 20' W	6' H x 40' W	15' H x 40' W	16' H x 12' W	8' H x 50' W	16' H x 11' W	3' H x 24' W
5 HP	20' H	11' H x 22' W	7' H x 48' W	20' H x 40' W	20' H x 20' W	10' H x 60' W	17' H x 17' W	5' H x 30' W



Fountain & Diffused Aeration

The Perfect Pairing for Ideal Pond Health & Beauty

LET A CERTIFIED AIRMAX INSTALLER DESIGN THE RIGHT SYSTEM FOR YOUR POND OR LAKE!

Fountains offer aesthetic beauty, relaxing sound, and great surface aeration. If you're looking to maximize the appearance and overall health of your pond or lake, consider supplementing your fountain with diffused aeration. Bottom-diffused aeration reduces muck, improves water clarity, and increases oxygen levels for a healthier overall ecosystem.

Our certified Airmax professionals will help you select the right fountain and aeration system for your unique needs.

HERE IS HOW TO GET YOUR LAYOUT:

Visit www.airmaxeco.com/airmax-assist and complete a short survey. Airmax will run this information along with input from your local Certified Installer through the Airmax Assist proprietary software to create a complete pond profile, detailed aeration placement map and a management plan.

Customer Information

Customer Number:	10532	Site Address:	123 Main St.
Customer Name:	John Smith	Date Created:	10/20/2018
Site Name:	John's Pond	Design Tech:	Scott Fox

Recommended Airmax® Aeration System(s)

Airmax® PondSeries PS20 Aeration System

Aerator Type	Direct Burial Size (inch)	Direct Burial Length (feet)	Weighted Aeration Size (inch)	Weighted Aeration Length (feet)
PS20-4	5/8	120	3/8	30
PS20-4	5/8	150	3/8	38
PS20-1	1 1/4	23	3/8	75

Pond Information

System Specifications:	Results for Aeration:		
Surface Acres:	33	Total Volume (gallons):	500,000
Average Depth:	7	Calculated Site Turnover (24hrs):	20.02
Acres Feet:	231	Estimated System PPG:	158
Deepend Diffuser Depth (feet):	15		
Perimeter (feet):	490		

1 of 3



Shallow Water Series® Aeration Systems
Single Systems Aerate up to 1/2 Acre



PondSeries® Aeration Systems
Single Systems Aerate up to 6 Acres



LakeSeries® Aeration Systems
Single Systems Aerate up to 12 Acres



LakeSeries 3 HP Crown & Gusher

Optional Fountain Accessories

Protect Your Investment & Make Installation a Breeze

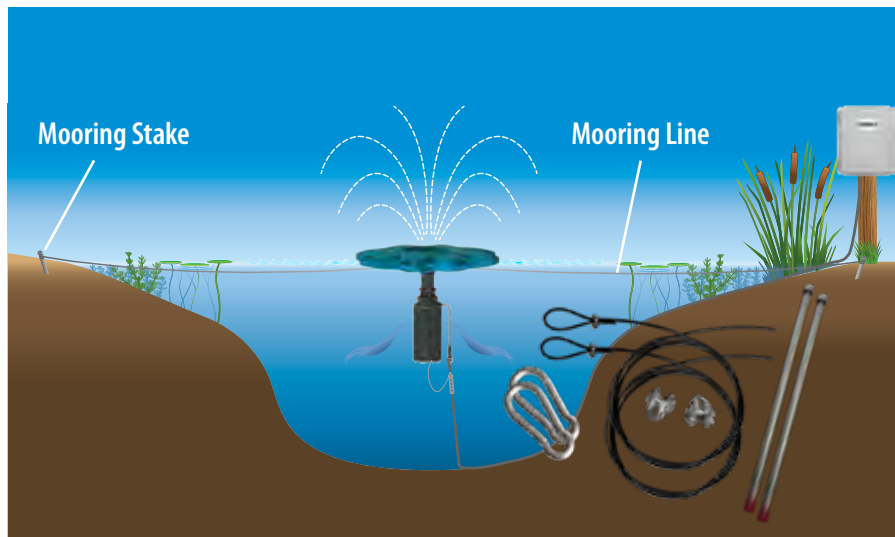

Mooring Kit

Fountains often move around with the wind and waves. You can secure your fountain by anchoring it using a Mooring Kit.

Each kit includes all necessary mooring supplies: two stakes, two carabiners, four cable clamps, and your choice of 150', 250' or 500' of black vinyl coated galvanized cable (mooring line). Works with all Airmax Fountain series.



Power Cord Protection

Nuisance pond wildlife such as beavers and muskrats are notorious for chewing wiring. Protect your fountain investment by upgrading your cord protection.

Power cords can be wrapped with our durable PolyFlex protective sheathing, or if you are looking for something more substantial, we highly recommend the stainless-steel option for the ultimate power cord protection.



Protect Your Investment With Upgraded Cord Protection



RGBW Color-Changing Lights

RF Remote with 200' Range



- Energy Efficient High Output LED, 120 Volt
- Completely Sealed, Adjustable Above Waterline Design for Low Maintenance
- All Light Sets Include Stainless-Steel Braiding on Power Lead and Between Light Fixtures
- Power Cords Come Standard with Strain Relief and Underwater Disconnect; 100' - 600' Lengths. Also Available with Stainless-Steel and Polyflex Protected Cords
- RF Remote with 200' Range is Included with All RGBW Color-Changing Light Sets
- Compatible With All Manufacturers' Fountains
- EcoSeries & PondSeries available in 2, 4 & 8 LED Light Sets
- LakeSeries Available in 9 & 12 LED Light Sets
- 3-Year Warranty



Sealed Adjustable Light Fixtures with an Easy Snap-on Design

Adjustable Color Temperature

Broader range of Kelvin allows for changes from cool white to warm white, and vibrant colors to pastels.



Warm White



Cool White



Pastel Blue



Vibrant Blue



Pastel Green



Vibrant Green



RGBW Lights 2700-6500K



Bring Your Fountain to Life

You Can Enjoy Your Fountain at All Hours – Even at Night!



SEE NIGHTTIME DISPLAYS IN ACTION
WATCH THE VIDEOS @ [AIRMAXECO.COM](https://airmaxeco.com)

Distributed By:

AIRMAX[®]
airmaxeco.com | 866.424.7629

EXHIBIT 23

RESOLUTION 2024-04

**A RESOLUTION OF THE BOARD OF SUPERVISORS OF BEACH
COMMUNITY DEVELOPMENT DISTRICT ADDING AN OFFICER
OF THE DISTRICT, AND PROVIDING FOR AN EFFECTIVE DATE**

WHEREAS, Beach Community Development District (hereinafter the "District") is a local unit of special-purpose government created and existing pursuant to Chapter 190, Florida Statutes, being situated entirely within Duval County, Florida; and

WHEREAS, the Board of Supervisors of the District desires to add an additional Officer of the District by appointment.

**NOW, THEREFORE, BE IT RESOLVED BY THE BOARD OF SUPERVISORS
OF BEACH COMMUNITY DEVELOPMENT DISTRICT:**

1. Scott Smith is added as an additional Assistant Treasurer by appointment.
2. This Resolution shall become effective at 12:01 a.m. on December 18, 2023.

PASSED AND ADOPTED THIS 18th DAY OF DECEMBER, 2023.

**BEACH COMMUNITY
DEVELOPMENT DISTRICT
CHAIRMAN / VICE CHAIRMAN**

ATTEST:

SECRETARY / ASSISTANT SECRETARY _____

EXHIBIT 24

RESOLUTION 2024-05

A RESOLUTION BY THE BOARD OF SUPERVISORS OF THE BEACH COMMUNITY DEVELOPMENT DISTRICT DESIGNATING SIGNATORIES FOR THE DISTRICT'S OPERATING BANK ACCOUNT(S); AND PROVIDING AN EFFECTIVE DATE.

WHEREAS, the Beach Community Development District (the "District") is a local unit of special-purpose government created and existing pursuant to Chapter 190, *Florida Statutes*, being situated entirely within Duval County, Florida;

WHEREAS, pursuant to Chapter 190, Florida Statutes, the funds of the District shall be disbursed by the Treasurer and by other such person(s) as may be authorized by the Board; and

WHEREAS, the Board has previously established a local operating bank account for the District; and

WHEREAS, the Board has previously designated authorized signatories on the bank account; and

WHEREAS, the Board desires to rescind and repeal the prior designation and designate new signatories on the account.

NOW BE IT THEREFORE RESOLVED BY THE BOARD OF SUPERVISORS OF THE BEACH COMMUNITY DEVELOPMENT DISTRICT THAT:

Section 1. The Chair and Vice-Chair of the District's Board of Supervisors, Scott Smith and Johanna Lee and Bridgett Alexander of DPGF Management and Consulting, LLC, are hereby designated as authorized signatories on the District's operating bank account.

Section 2. This Resolution shall take effect upon its passage and shall remain in effect unless rescinded or repealed. Further, upon its passage, any previously adopted resolution designating signatories on bank accounts for the District is rescinded and repealed.

PASSED AND ADOPTED this 18th day of December, 2023.

ATTEST:

BEACH COMMUNITY DEVELOPMENT DISTRICT

Secretary/Assistant Secretary

Chair, Board of Supervisors

EXHIBIT 25

Bob's Backflow & Plumbing Services, Inc.

4640 Subchaser Ct, Ste 113
Jacksonville, FL 32244

Phone # 904-268-8009 Fax # 904-292-4403

www.bobsbackflow.com

FL Plumbing License
RF0053877
Fire License
20271900012010

Proposal

Date 12/5/2023
Proposal # 23256

Name / Address		Job Location	
Beach CDD 12788 Meritage Blvd. Jacksonville, FL 32246		Beach Community Development 12988 Meritage Blvd Jacksonville, FL 32246	
Customer Phone	Customer Fax	P.O. No.	Work Order #
904-577-3075			N/A

Description	Qty	Cost	Total
Bob's Backflow & Plumbing Services, Inc. proposes to replace the following backflow due to a failing annual backflow certification test.			
2" Wilkins 975XL S#:4270448 - Potable			
Labor 2 Men to replace the existing backflow preventer, clean, flush, test, and certify.	1.5	180.00	270.00
2" Wilkins 975XL2	1	876.00	876.00
Piping & Materials	1	60.00	60.00
Insulation to protect the device against future freeze damage.	1	60.00	60.00
Backflow Test: Backflow Test/ Certified and submitted to proper Water Utility Provider	1	0.00	0.00
Normal Business Hrs. M-F 8:00am - 4:00 pm. Overtime rates apply to repairs outside these hrs.			

<p>Bob's Backflow & Plumbing Services, Inc. is not responsible for any work done or materials used by other contractors prior to our arrival on site. We are not responsible for any damages to buildings or their contents, fixtures, concrete or asphalt, landscaping, wires, piping, unmarked private utilities, etc. that is not directly caused by the work we have completed.</p>	Total \$1,266.00
	This Proposal may be withdrawn after (30) days if not signed and returned.
	All work is to be done during normal business hours unless indicated or additional charges will be incurred.

Signature if Accepted _____

EXHIBIT 26

Date of Action Item	Action Item	Status
	Field Operations Manager/Amenity Manager Section	
4/17/2023	FOM to visit Durbin Crossing regarding pool lanes	Scheduled for 12-14-23
7/17/2023	FOM to obtain quotes for beam over visitors entrance lane at guard house	Underway—FOM is going to install
7/17/2023	FOM to obtain quote for shade on playground.	Underway. Initial quote provided at 9/18 meeting. Guidance provided to staff regarding future quotes including drawings; also provide financing information when doing budget for FY 2025
9/18/2023	FOM to obtain quotes to have tree stakes removed from landscaping	10/16/2023: Tabled until 11/20 meeting for better direction; FOM has begun removing stakes near Tamaya Hall as time permits. Price from Tree Amigos is \$13.85 per stake to remove
10/16/2023	FOM to obtain quotes for pool lighting replacement	Underway
10/16/2023	FOM to obtain quotes for Tamaya Blvd. lighting and pictures of areas covered by quotes	Underway. FOM needs additional clarification from Board as some of the property is not owned by District.
10/16/2023	AM to research if CPR classes can be conducted for residents	Underway
10/16/2023	AM to obtain quotes for Summer Camp	Underway
11/20/2023	FOM to Take Pictures for Files for Sidewalk Repair on Savona Court	Signed proposal sent and waiting for repair date.
11/20/2023	FOM to get quotes to replace carpet in Tamaya Hall	See if carpet is needed.

11/20/2023	FOM to get quote for portable pressure washing machine	Under way to get proposal for 4200psi pressure washer and sidewalk scrubber. need more board direction on what all is included.
11/20/2023	FOM to establish schedule to pressure wash assets of the District	Underway
11/20/2023	FOM to obtain proposal to remove ornamental grasses from intersection of Cassia and Meritage and to replace with sod	Underway
11/20/2023	FOM to obtain quotes for trimming trees on CDD property in front of homes whose branches are blocking the use of sidewalks	Underway
11/20/2023	FOM to look into a scanner for QR Codes and ability for clickers/transponders for use of resident's side of entry gate	Underway
11/20/2023	AM to send out E-Blast with new operating hours after Thanksgiving	Completed
11/20/2023	AM to add YTD amounts in Amenity Manager's Report	Underway
11/20/2023	AM to hold workshop on event ideas (approximately every 6 months)	Scheduled for January 9 th , 2024
11/20/2023	AM to send out an E-Blast when AED is purchased and installed with links on how to use it.	Completed
	District Manager Section	
9/18/2023	DM to check with Skye about having credit cards with "Capital One" type reward points	Underway
9/18/2023	DM to seek reimbursement from ICI for tree removed near basketball court	Underway 11/15: Letter sent
10/16/2023	DM to send out approved letter to commercial property owners along Tamaya Boulevard (send UPS Tracking). Amend letter to include language provided by Dr. Renn	Underway 10/20: Letter sent; 10/27 and 11/15: follow ups made

11/20/2023	DM to send draft Post Orders from Advanced Security to Board	Done
11/20/2022	DM to request Joe Brown speak to Board regarding litigation steps for oak tree damage	On 12/18 Agenda
11/20/2023	DM to contact vendors and request that they submit what they recommend a scorecard to look like with respect to their services	Underway: Due to DM on 12/21
	District Engineer Section	
	District Counsel Section	
9/18/2023	DC to provide resolution for the 10/16 meeting regarding tree removals on CDD owned ROW	On hold pending outcome of this matter
11/20/2023	DC to review Tree Amigos merger and see if changes are necessary to the Landscape Maintenance contract	
11/20/2023	DC to work with POA/HOA attorney to see if an agreement can be reached regarding on-street overnight parking.	12/1: Per POA, no interest in pursuing.
11/20/2023	DC to research and determine if roads were permitted with parking restrictions and if so, can amenity policies be amended to address the on-street overnight parking issue	
	Board of Supervisors Section	

EXHIBIT 27

BEACH CDD MEETING AGENDA MATRIX

December, 2023	Regular Meeting: 12/18	<p>Vendor Reports</p> <ul style="list-style-type: none"> • Field Manager Report—Speed Bump Installation consideration <p>Presentations</p> <p>Consent Agenda Items</p> <ul style="list-style-type: none"> • Meeting Minutes--11/20/2023 Regular Meeting • Unaudited Financials <ul style="list-style-type: none"> ○ November 2023 ○ June 2023-August 2023—all revised • Integrated Access Solutions Invoice for Emergency Repair <p>Business Items</p> <ul style="list-style-type: none"> • Consideration of Arbitrage Engagement Letters for periods ending 11/3/2024 and 11/3/2025 • Acceptance of Parcels from Developer • Consideration of Amenity Center Fountain Replacement Proposal <p>Discussions</p> <ul style="list-style-type: none"> • Board discussion with Joseph Brown, Esquire • Board discussion with Trustee <p>Staff Reports</p> <ul style="list-style-type: none"> • District Manager <ul style="list-style-type: none"> ○ Resident(s) Subject to Disciplinary Action ○ Incident Report Tracker 	<ul style="list-style-type: none"> • Approved by DM in conjunction with Chair’s approval • Not considered during 11/20 meeting • Deferred from 11/20 meeting—use same exhibits • Possible litigation process
-----------------------	-----------------------------------	--	--

BEACH CDD MEETING AGENDA MATRIX

		<ul style="list-style-type: none">○ Action Item Report○ Meeting Matrix • District Counsel • District Engineer	
--	--	--	--

BEACH CDD MEETING AGENDA MATRIX

January, 2024	Regular Meeting: 1/15	<p><i>Vendor Reports</i></p> <p><i>Presentations</i></p> <p><i>Consent Agenda Items</i></p> <ul style="list-style-type: none"> • Meeting Minutes--12/18/2023 Regular Meeting • Unaudited Financials--December 2023 <p><i>Business Items</i></p> <p><i>Discussions</i></p> <ul style="list-style-type: none"> • Board discussion with Trustee (if not done on 12/18) <p><i>Staff Reports</i></p> <ul style="list-style-type: none"> • District Manager <ul style="list-style-type: none"> ○ Resident(s) Subject to Disciplinary Action ○ Incident Report Tracker ○ Action Item Report ○ Meeting Matrix ○ FY 2025 Draft Budget Presented • District Counsel • District Engineer 	
----------------------	----------------------------------	---	--

BEACH CDD MEETING AGENDA MATRIX

<p>February, 2024</p>	<p>Regular Meeting: 2/19</p>	<p>Vendor Reports</p> <p>Presentations</p> <p>Consent Agenda Items</p> <ul style="list-style-type: none">• Meeting Minutes--1/15/2024 Regular Meeting• Unaudited Financials--January 2024 <p>Business Items</p> <p>Discussions</p> <ul style="list-style-type: none">• FY 2025 Draft Budget--continued <p>Staff Reports</p> <ul style="list-style-type: none">• District Manager<ul style="list-style-type: none">○ Resident(s) Subject to Disciplinary Action○ Incident Report Tracker○ Action Item Report○ Meeting Matrix• District Counsel• District Engineer	
------------------------------	---	--	--

BEACH CDD MEETING AGENDA MATRIX

March, 2024	Regular Meeting: 3/18	<p>Vendor Reports</p> <p>Presentations</p> <p>Consent Agenda Items</p> <ul style="list-style-type: none">• Meeting Minutes—2/19/2024 Regular Meeting• Unaudited Financials—February 2024 <p>Business Items</p> <p>Discussions</p> <p>Staff Reports</p> <ul style="list-style-type: none">• District Manager<ul style="list-style-type: none">○ Resident(s) Subject to Disciplinary Action○ Incident Report Tracker○ Action Item Report○ Meeting Matrix• District Counsel• District Engineer	
--------------------	----------------------------------	---	--

BEACH CDD MEETING AGENDA MATRIX

<i>Unscheduled Items</i>	<p><i>Presentations</i></p> <ul style="list-style-type: none"> • Bank account presentation by Skye Lee <p><i>Consent Agenda Items</i></p> <p><i>Business Items</i></p> <p><i>Discussions (Workshop)</i></p> <ul style="list-style-type: none"> • CDD Agreement to allow HOA to enforce no parking on CDD owned streets • Trees/Tree Damage • Overnight Parking on Roadway—Make this a violation of Amenity Policies • Vendor Scorecards • Advanced Security Issues • Additional Testing of Pool Water • Discipline Process • Agreement with City of Jacksonville for off-duty patrol of police • Post Orders <p><i>Staff Reports</i></p> <p><i>Public Hearing</i></p> <p><i>Vendor Reports</i></p> <ul style="list-style-type: none"> • Second speed study conducted by Jake 		<ul style="list-style-type: none"> • Could be done during a workshop • 2/7: Reply from HOA • From 11/20 meeting • Based on issue of indemnification, the Board tabled this matter on 7/17/2023. • Supervisor Korsakova has requested receiving the raw data
--------------------------	--	--	--

BEACH CDD MEETING AGENDA MATRIX

SUBJECT	NOTES
Safety and Security	<ul style="list-style-type: none">• Speeding in Community• Single Point of Entry/Sign-In Point for Amenities• Point of Entry for Sidewalks
Expanding Amenities	<ul style="list-style-type: none">• Facilitators
Pocket Parks	<ul style="list-style-type: none">• Beautification

BEACH CDD MEETING AGENDA MATRIX

MAJOR CONTRACT VENDOR NAME/SERVICE	EXPIRATION DATE/COMMENTS
Amenity Management/Vesta Property Services	12/13/2021-9/30/2025 (District 60 days without cause; Contractor has 90 days). First Amendment was effective on 2/7/2022.
Aquatic Management/Lake Doctors	10/1/202-9/30/2024 (30 days)
Arbitrage Services/LLS Tax Solutions	Period ending 11/3/2023
Audit Services/DMHB	Fiscal Year ending 9/30/2024
Cintas/AED Lease-Purchase	Ending 11/2026
Criminal Background Checks/Screening One	3/15/2023-1 year auto renewal
District Counsel Services/Kutak Rock LLP	12/27/2022-
District Engineer Services/England-Thims & Miller, Inc.	9/18/2023-9/30/2024
District Management Services/DPFG (d/b/a Vesta District Services)	5/1/2022- 9/30/2023-1 year auto renewal
Fire Alarm Monitoring & Inspection/Wayne Automatic Fire Sprinklers, Inc.	10/1/2022-10/1/2023-auto renews for 1 year twice (60 days for failure to perform; 30 days without cause)
Janitorial Services—Jani-King Inc	9/27/2023-9/30/2024 – 1 year auto renewal 5 times (30 days)
Landscape Maintenance/Tree Amigos Outdoor Services, Inc.	7/1/2023-6/30/2026 (60 days for failure to perform; 30 days without cause)
Pest Control/Turner Pest Control	3/23/2017-
Security Guard Service/Advanced Security Specialist & Consulting LLC	1/21/2021- (District and Contractor 30 days without cause); First Amendment was effective on 9/28/2021; Second Amendment was effective on 10/13/2022; Third Amendment was effective on 3/5/2023
Towing Service/ASAP Towing and Storage	12/6/2022-
Website Hosting/Campus Suite	4/1/2022-9/30/2022; 1 year auto renewal